

UNIVERSIDAD DE MÁLAGA  
ESCUELA TÉCNICA SUPERIOR DE INGENIERÍA DE TELECOMUNICACIÓN  
PROGRAMA DE DOCTORADO EN INGENIERÍA DE TELECOMUNICACIÓN



TESIS DOCTORAL

# CONTEXT-AWARE SELF-HEALING FOR SMALL CELL NETWORKS

Autor:  
SERGIO FORTES RODRÍGUEZ

Directora:  
RAQUEL BARCO MORENO

2017



UNIVERSIDAD  
DE MÁLAGA

AUTOR: Sergio Fortes Rodríguez

 <http://orcid.org/0000-0002-5857-6403>

EDITA: Publicaciones y Divulgación Científica. Universidad de Málaga



Esta obra está bajo una licencia de Creative Commons Reconocimiento-NoComercial-SinObraDerivada 4.0 Internacional:

<http://creativecommons.org/licenses/by-nc-nd/4.0/legalcode>

Cualquier parte de esta obra se puede reproducir sin autorización pero con el reconocimiento y atribución de los autores.

No se puede hacer uso comercial de la obra y no se puede alterar, transformar o hacer obras derivadas.

Esta Tesis Doctoral está depositada en el Repositorio Institucional de la Universidad de Málaga (RIUMA): [riuma.uma.es](http://riuma.uma.es)





Por la presente, la **Dra. D<sup>a</sup>. Raquel Barco Moreno**, profesora del *Departamento de Ingeniería de Comunicaciones* de la Universidad de Málaga,

**CERTIFICA:**

Que **D. Sergio Fortes Rodríguez**, Ingeniero de Telecomunicación, ha realizado en el Departamento de Ingeniería de Comunicaciones de la Universidad de Málaga bajo su dirección, el trabajo de investigación correspondiente a su TESIS DOCTORAL titulada:

**“Context-Aware Self-Healing for Small Cell Networks”**

En dicho trabajo se han propuesto aportaciones originales para la gestión de problemas en redes móviles. En particular, se han propuesto métodos para la detección de fallos y para los sistemas de diagnóstico automática. Los resultados expuestos han dado lugar a publicaciones en revistas y aportaciones a congresos.

Por todo ello, consideran que esta Tesis es apta para su presentación al Tribunal que ha de juzgarla. Y para que conste a efectos de lo establecido, AUTORIZA la presentación de esta Tesis en la Universidad de Málaga.

Málaga, a \_\_\_\_ de \_\_\_\_\_ de \_\_\_\_\_.

Fdo.: Dra. D<sup>a</sup>. Raquel Barco Moreno





UNIVERSIDAD  
DE MÁLAGA

UNIVERSIDAD DE MÁLAGA  
ESCUELA TÉCNICA SUPERIOR DE INGENIERÍA DE TELECOMUNICACIÓN  
PROGRAMA DE DOCTORADO EN INGENIERÍA DE TELECOMUNICACIÓN

Reunido el tribunal examinador en el día de la fecha, constituido por:

Presidente: Dr. D. \_\_\_\_\_

Secretario: Dr. D. \_\_\_\_\_

Vocal: Dr. D. \_\_\_\_\_

para juzgar la Tesis Doctoral titulada *Context-Aware Self-Healing for Small Cell Networks* realizada por D. Sergio Fortes Rodríguez, y dirigida por la Dra. D<sup>a</sup>. Raquel Barco Moreno, acordó por

\_\_\_\_\_ otorgar la calificación de

\_\_\_\_\_ y para que conste,

se extiende firmada por los componentes del tribunal la presente diligencia.

Málaga, a \_\_\_\_ de \_\_\_\_\_ de \_\_\_\_\_.

El Presidente:

Fdo.: \_\_\_\_\_

El Secretario:

El Vocal:

Fdo.: \_\_\_\_\_ Fdo.: \_\_\_\_\_



UNIVERSIDAD  
DE MÁLAGA

*A mis padres y a mi esposa Ángeles,  
sin los cuales este trabajo no hubiera sido posible,  
y a mí pequeña Edelvais,  
para el día en que ya sepa leer estas palabras.*



UNIVERSIDAD  
DE MÁLAGA

*“Das Leben ist wert, gelebt zu werden,  
sagt die Kunst, die schönste Verführerin;  
das Leben ist wert, erkannt zu werden,  
sagt die Wissenschaft.”*

Friedrich Nietzsche (1844-1900)



UNIVERSIDAD  
DE MÁLAGA

# Acknowledgments

No research is done alone, and the present work was not to be an exception. This thesis stands, as it is said, *on the shoulders of giants*. Just trying to summarily recognize their support and help, I write these acknowledgments.

This work has its roots, from a personal perspective, in my first professional steps in the telecommunications sector. Korbinian Frank was the first one that gave me, a very “green” student at that time, the chance to go abroad and work under his supervision in the German Aerospace Agency (DLR). Long time has passed since then, when even writing an email in barely-understandable English took hours of effort. His patience, perfectionism and experience provided the starting point for all my subsequent development. He, together with Raquel Barco, guided my master’s thesis and resulting publications, teaching me for the first time the ways of research.

“Do not Pick a Job. Pick a Boss” is a remark that has recently gain popularity, referring to the importance of working for inspiring and enlightening people, especially at the beginning of a professional career. Without realizing it, I luckily continued collaborating with a plethora of enthusiastic, knowledgeable and passionate professionals: Hugo González from the French Aerospace Agency (CNES), Catherine Morlet and Nathalie Ricard from the European Space Agency (ESA) and Graham Peters from Avanti. All of them taught me very important technical knowledge and life lessons that enriched me as an engineer/researcher, and as a person.

I also learned a lot and received extraordinary support from many of the colleagues I met along the way. All the great moments enjoying the near-infinite knowledge of Raúl Cerdán, Santiago Garcia and last, but not least, Vicente Escaño, who also provided and invaluable reader feedback to this thesis. The discussions with Erling and the coffee breaks at ESA (with my dear Daniel, Edith, Julia, Sylvain, Julien...). The extraordinarily long work days spent with Nikos or the conversations with Mo and Mohaned. All of these moments were as enlightening, professionally and personally, as any course I could had.

After these experiences, I returned to Málaga to join the research group TIC-102 of the department *Ingeniería de Comunicaciones*. I want to inestimably thank



Raquel Barco, who trusted me to work in her team and accepted to be my thesis supervisor. I could not have found a more enthusiastic, understanding and knowledgeable person to guide this research. Since day one, Raquel has been an extraordinary director encouraging, leading and also giving me responsibility in my work.

Especial thanks also to my long-time colleague and friend Alejandro Aguilar, collaborator and co-father of an important part of this work. His resolution, hard-work and unbreakable spirit lead us both out of many stressful and backbreaking deadlines. Without his support, these years would have been for sure far less inventive and enjoyable.

I would also like to acknowledge all the professors and colleagues in the research team, and, particularly those in the mobile network optimization group. Without the previous works, tools and support of Matías Toril, Salvador Luna, Jose-María Ruiz-Avilés, Pablo Muñoz, Emil Khatib, Isabel de la Bandera, and many others, this study would have been unachievable. Also thanks to Eduardo Baena, who kindly contributed with his comments to the manuscript.

Most of this thesis was developed under the umbrella of the MONOLOC project, centered on innovative techniques for indoor localization and cellular network management. Thus, I cannot miss the opportunity to thank our colleagues from other MONOLOC's partner institutions, which collaborated in these developments: Alcatel - Lucent, Universidad Politécnica de Madrid, Universidad Carlos III de Madrid and INNOVATI. A relevant part of the input data used in this works was obtained thanks to their applications, equipment and expertise.

Moreover, I want to thank Ericsson Málaga, which supported part of my post-thesis research. Here, I am especially grateful to Inmaculada Serrano, for her understanding and support during the completion of this thesis.

Thanks also to all those who welcome the different research stays during the thesis, as Elizabeth Collins (ESIGETEL), George Dimitrakopoulos (Harokopio University), Henk Wymeersch (Chalmers University of Technology), Christoph Bach and Luis Barragán (Ericsson Germany). Apart from enriching my research, they all welcomed me with open arms and immediately made me feel as part of their teams.

Besides, I wish also to recognize the love, work and dedication of my parents and the fellowship of my brother, which together brought me here. Thanks for being always there and establish the basis of who I am. I also want to dedicate this thesis to my wife, Angeles, for her love, support and the uncountable situations when she has suffered my absent-mindedness and lack-of-time in the long hours, days and months dedicated to it.

Finally, thank you, dear Reader. I hope that this thesis will be interesting and helpful for you.



This thesis have been partially supported by:

- Spanish Ministry of Economy and Competitiveness, under the projects MONOLOC (reference: MONOLOC-IPT-2011-1272-430000) and the network of excellence Red ARCO 5G (TEC2014-56469-REDT).
- *European Development Fund* (ERDF), also supporter of the project MONOLOC.
- Junta de Andalucía, under projects TIC2905 and P08-TIC-04052.



UNIVERSIDAD  
DE MÁLAGA

# Summary of contributions

The different publications resulted from this research are listed below including first those supporting the thesis.

## Journal articles

- [1] S. Fortes, R. Barco, and A. Aguilar-Garcia, “Location-based distributed sleeping cell detection and root cause analysis for 5G ultra-dense networks,” *EURASIP Journal on Wireless Communications and Networking*, vol. 2016, pp. 1–18, June 2016. (IF 2016: 1.529 - Q3)<sup>1</sup>
- [2] S. Fortes, A. A. Garcia, J. A. Fernandez-Luque, A. Garrido, and R. Barco, “Context-Aware Self-Healing: User Equipment as the Main Source of Information for Small-Cell Indoor Networks,” *IEEE Vehicular Technology Magazine*, vol. 11, pp. 76–85, March 2016. (IF 2016: 4.429 - Q1).
- [3] S. Fortes, R. Barco, A. Aguilar-García, and P. Muñoz, “Contextualized indicators for online failure diagnosis in cellular networks,” *Computer Networks*, vol. 82, pp. 96 – 113, April 2015. (IF 2015: 1.446 - Q2).
- [4] S. Fortes, A. Aguilar-García, R. Barco, F. Barba, J. Fernández-Luque, and A. Fernández-Durán, “Management architecture for location-aware self-organizing LTE/LTE-A small cell networks,” *Communications Magazine, IEEE*, vol. 53, pp. 294–302, January 2015. (IF 2015: 5.125 - Q1).

---

<sup>1</sup>For the works published in journals, their *impact factor* (IF) and quartile (represented as QX, where ‘X’ is its order) is included.

*Additional contributions:*

- [5] A. Aguilar-Garcia, S. Fortes, A. F. Duran, and R. Barco, “Context-Aware Self-Optimization: Evolution Based on the Use Case of Load Balancing in Small-Cell Networks,” *IEEE Vehicular Technology Magazine*, vol. 11, pp. 86–95, March 2016. (IF 2016: 4.429 - Q1).
- [6] A. Aguilar-Garcia, S. Fortes, E. Colin, and R. Barco, “Enhancing RFID indoor localization with cellular technologies,” *EURASIP Journal on Wireless Communications and Networking*, vol. 2015, no. 1, 2015. (IF 2015: 0.627 - Q3).
- [7] A. Aguilar-Garcia, S. Fortes, M. Molina-García, J. Calle-Sánchez, J. I. Alonso, A. Garrido, A. Fernández-Durán, and R. Barco, “Location-aware self-organizing methods in femtocell networks,” *Computer Networks*, vol. 93, Part 1, pp. 125 – 140, 2015. (IF 2015: 1.446 - Q2).
- [8] A. Aguilar-Garcia, R. Barco, S. Fortes, and P. Muñoz, “Load balancing mechanisms for indoor temporarily overloaded heterogeneous femtocell networks,” *EURASIP Journal on Wireless Communications and Networking*, vol. 2015, p. 29, feb 2015. (IF 2015: 0.627 - Q3).
- [9] P. Muñoz, R. Barco, and S. Fortes, “Conflict Resolution Between Load Balancing and Handover Optimization in LTE Networks,” *Communications Letters, IEEE*, vol. 18, pp. 1795–1798, Oct 2014. (IF 2014: 1.268 - Q2).

## Patents

- [10] S. Fortes, R. Barco, and I. Serrano, “Cellular Network Management Based on Automatic Social-Data Acquisition.” International Patent. Filling reference PCT/EP2017/060312. Filled on May, 1, 2017.
- [11] S. Fortes, R. Barco, P. Muñoz Luengo, and I. Serrano, “Method and Network Node for Detecting Degradation of Metric of Telecommunications Network.” International Patent. Filling reference PCT/EP2016/064144. Filled on June, 20, 2016.



## International conferences/workshops

- [12] S. Fortes, P. Oliver, M. Toril, D. Palacios, S. Luna, and R. Barco, “Future 5G SON: University of Málaga - Mobilenet Group Approach and Perspectives: MobileNet team and Self-healing/optimization team - research topics,” in *IRACON 2nd MC meeting and first technical meeting*, September 2016.
- [13] S. Fortes, A. Aguilar-Garcia, J. A. Fernandez-Luque, A. Garrido, and R. Barco, “Location-Based User Equipment Identification of Failures in Femtocell Networks,” in *IRACON 2nd MC meeting and first technical meeting*, May 2016.
- [14] S. Fortes, R. Barco, A. Aguilar-García, and P. Muñoz, “Integration of Mobile Context in the Diagnosis of Small Cell Networks,” in *Joint NEWCOM/COST Workshop on Wireless Communications - JNCW 2015*, Oct 2015.
- [15] S. Fortes, R. Barco, and A. Aguilar-García, “Location-Based Distributed Failure Management for 5G Ultra-Dense Small Cell Networks,” in *Workshop on Evolution of Radio Access Network Technologies towards 5G*, May 2015.
- [16] S. Fortes, R. Barco, and A. Aguilar-García, “Integration of Indoor Positioning into Self-Organizing Small Cell Systems,” in *12th IC1004 MC and Scientific Meeting*, Jan 2015.

### *Additional contributions:*

- [17] A. Aguilar-García, S. Fortes, E. Collins, and R. Barco, “Enhancing Localization Accuracy with Multi-Antenna UHF RFID Fingerprinting,” in *IPIN 2015, Sixth International Conference on Indoor Positioning and Indoor Navigation*, Oct 2015.
- [18] A. Aguilar-García, R. Barco, S. Fortes, and P. Muñoz, “Analysis of overload indicators for traffic balance in indoor femtocell networks,” in *13th IC1004 MC and Scientific Meeting*, May 2015.

## National conferences/workshops

- [19] S. Fortes, A. Aguilar-García, and R. Barco, “Identificación de Fallos Radio en Entornos Celulares Localizados de Interior,” in *XXX Simposium Nacional de la Unión Científica Internacional de Radio - URSI 2015*, Sep 2015.



- [20] S. Fortes, A. Aguilar-García, and R. Barco, “Detección de Celda Durmiente en Entornos Localizados de Femtoceldas,” in *XXIX Simposium Nacional de la Unión Científica Internacional de Radio - URSI 2014*, Sep 2014.
- [21] S. Fortes, A. Aguilar-Garcia, and R. Barco, “Location-Based User Equipment Identification of Failures in Femtocell Networks: Self-healing,” in *Workshop sobre localización en interiores con small cells. Conclusiones del proyecto MONOLOC*, Alcatel-Lucent, Nov 2014. Accessed: 2017-03-01.
- [22] S. Fortes, A. Aguilar-García, R. Barco, F. Barba, J. Fernández-Luque, and A. Fernández-Durán, “Diseño Integrado de Redes Auto-Organizadas LTE/LTE-A y Posicionamiento en Interiores,” in *XXVIII Simposium Nacional de la Unión Científica Internacional de Radio - URSI 2013*, Sep 2013.

*Additional contributions:*

- [23] A. Aguilar-García, S. Fortes, and R. Barco, “Análisis de indicadores para el balance de carga en redes de femtoceldas,” in *XXX Simposium Nacional de la Unión Científica Internacional de Radio - URSI 2015*, Sep 2015.
- [24] A. Aguilar-García, S. Fortes, and R. Barco, “Información de contexto en la auto-gestión de redes small cells,” in *XXIX Simposium Nacional de la Unión Científica Internacional de Radio - URSI 2014*, Sep 2014.

# Contents

<b>Abstract</b>	<b>xxxi</b>
<b>Resumen</b>	<b>xxxv</b>
<b>Acronyms</b>	<b>xxxix</b>
<b>I Background</b>	<b>1</b>
<b>1 Introduction</b>	<b>3</b>
1.1 Motivation . . . . .	3
1.2 Preliminaries . . . . .	6
1.3 Objectives . . . . .	7
1.4 Thesis structure . . . . .	9
<b>2 Cellular networks technical overview</b>	<b>11</b>
2.1 Cellular standards . . . . .	12
2.2 LTE . . . . .	14
2.2.1 Radio access . . . . .	15
2.2.2 Network architecture . . . . .	17
2.3 OAM reference model . . . . .	20
2.4 Small cells . . . . .	22
2.5 5G perspectives . . . . .	24
2.6 Conclusions of the chapter . . . . .	26
<b>II Context and SON integration</b>	<b>27</b>
<b>3 SON, self-healing and context in small cell environments</b>	<b>29</b>
3.1 Self-organizing networks . . . . .	30



3.1.1	SON in the 3GPP standards . . . . .	32
3.1.2	Related projects . . . . .	33
3.2	Self-healing . . . . .	36
3.2.1	Principles . . . . .	36
3.2.2	General scheme . . . . .	39
3.2.3	Network variables . . . . .	40
3.2.4	State of the art . . . . .	43
3.3	Context . . . . .	48
3.3.1	Related work . . . . .	48
3.3.2	Indoor localization techniques . . . . .	49
3.3.3	Wrap-up . . . . .	50
3.4	Small cell challenges and context-awareness . . . . .	50
3.5	SON-aware context . . . . .	55
3.6	Conclusions of the chapter . . . . .	55
<b>4</b>	<b>Management architecture for context-aware SON</b>	<b>57</b>
4.1	Motivation . . . . .	59
4.2	Problem description . . . . .	60
4.2.1	Sources of context data . . . . .	61
4.2.2	Challenges for the architecture . . . . .	62
4.3	Proposed SON architecture . . . . .	65
4.3.1	Objectives . . . . .	65
4.3.2	Functional model . . . . .	65
4.3.3	SON entity options . . . . .	70
4.3.4	Implementation model for femtocell LTE/LTE-A deployments	70
4.3.5	System responsibility . . . . .	72
4.4	Proof of concept: load balancing . . . . .	73
4.4.1	Baseline algorithm . . . . .	74
4.4.2	Evaluation . . . . .	78
4.5	Context traffic assessment . . . . .	81
4.5.1	UE context report . . . . .	82
4.5.2	Comparison with cellular networks capacity . . . . .	83
4.6	Conclusions of the chapter . . . . .	85



<b>III</b>	<b>Context-aware self-healing</b>	<b>87</b>
<b>5</b>	<b>Context-aware self-healing framework</b>	<b>89</b>
5.1	Motivation . . . . .	90
5.2	Framework . . . . .	90
5.2.1	UE-profiling based model . . . . .	91
5.3	Proof of concept: cell outage detection . . . . .	94
5.3.1	Statistical profile generation . . . . .	94
5.3.2	Detection and diagnosis algorithm . . . . .	96
5.3.3	Non-context mechanism . . . . .	96
5.4	Test trial . . . . .	97
5.4.1	Set-up . . . . .	97
5.4.2	Evaluation . . . . .	98
5.5	Conclusions of the chapter . . . . .	101
<b>6</b>	<b>Contextualized network indicators</b>	<b>103</b>
6.1	Motivation . . . . .	104
6.2	Contextualized indicators . . . . .	106
6.2.1	Statistics calculation . . . . .	107
6.2.2	Weight masks . . . . .	108
6.2.3	Binary weights . . . . .	109
6.3	Context-aware diagnosis . . . . .	110
6.3.1	Training phase . . . . .	111
6.3.2	Online phase . . . . .	111
6.3.3	Data scarcity avoidance . . . . .	113
6.3.4	Diagnosis scheme . . . . .	113
6.4	Implementation considerations . . . . .	115
6.4.1	Hybrid and distributed approaches . . . . .	115
6.4.2	Classifier inputs selection . . . . .	116
6.4.3	Mask information sources . . . . .	117
6.4.4	Re-training needs . . . . .	118
6.4.5	Computational cost overview . . . . .	119
6.5	Diagnosis evaluation . . . . .	120
6.5.1	Learning phase . . . . .	122
6.5.2	Online Phase . . . . .	126
6.5.3	Impact of localization error . . . . .	131



6.6	Conclusions of the chapter . . . . .	132
<b>7</b>	<b>Distributed approach for sleeping cell analysis</b>	<b>133</b>
7.1	Motivation . . . . .	134
7.2	Radio information application . . . . .	135
7.2.1	UE radio measurements . . . . .	135
7.2.2	Location-based measurements processing . . . . .	137
7.2.3	Sample weights and AOIs for the detection of sleeping cells . .	140
7.2.4	AOIs calculation approaches . . . . .	141
7.3	Detection algorithm . . . . .	144
7.3.1	Training phase . . . . .	145
7.3.2	Online phase . . . . .	147
7.3.3	Confidence level definition . . . . .	148
7.4	Diagnosis of sleeping cell causes . . . . .	149
7.5	Distributed self-healing . . . . .	150
7.5.1	Procedure . . . . .	151
7.5.2	Implementation . . . . .	154
7.6	Evaluation . . . . .	155
7.6.1	Impact of sleeping cell fault in classic indicators . . . . .	155
7.6.2	RSS indicators and AOIs . . . . .	156
7.6.3	Impact of UE localization error . . . . .	160
7.7	Conclusions of the chapter . . . . .	162
<b>IV</b>	<b>Conclusions</b>	<b>163</b>
<b>8</b>	<b>Conclusions</b>	<b>165</b>
8.1	Main contributions . . . . .	165
8.2	Future work . . . . .	167
8.3	Final remarks . . . . .	168
	<b>Appendices</b>	<b>173</b>
<b>A</b>	<b>Assessment tools</b>	<b>173</b>
A.1	LTE system level simulator . . . . .	173
A.1.1	Author's contributions . . . . .	176
A.2	Indoor femtocell testbed . . . . .	179
A.2.1	Author's contributions . . . . .	180



<b>B Summary (Spanish)</b>	<b>183</b>
B.1 Introducción . . . . .	184
B.1.1 Objetivos . . . . .	187
B.1.2 Organización del trabajo . . . . .	188
B.2 Perspectiva de las redes celulares . . . . .	189
B.3 SON, auto-curación y contexto en entornos de celdas pequeñas . . . . .	191
B.3.1 Auto-curación . . . . .	192
B.3.2 Retos de las celdas pequeñas para la auto-curación . . . . .	192
B.3.3 Conciencia de contexto . . . . .	193
B.4 Arquitectura integrada de SON y contexto . . . . .	195
B.5 Framework para la auto-curación basada en contexto . . . . .	197
B.6 Indicadores contextualizados . . . . .	199
B.7 Enfoque distribuido para el análisis de celdas durmientes . . . . .	200
B.8 Contribuciones principales . . . . .	200
B.9 Lista de publicaciones . . . . .	202
<b>Bibliography</b>	<b>225</b>



UNIVERSIDAD  
DE MÁLAGA

# List of Figures

1.1	Conceptual scheme of the objectives addressed in the thesis. . . . .	8
1.2	Organization of the chapters. . . . .	9
2.1	3GPP main standard releases [43]. . . . .	12
2.2	Mobile subscriptions by technology (billions) [43]. . . . .	14
2.3	LTE access schemes [43]. . . . .	15
2.4	REs and RBs in LTE [49]. . . . .	16
2.5	Carrier aggregation in LTE-A [43]. . . . .	17
2.6	LTE user and control planes architecture [50]. . . . .	19
2.7	Management reference model [52]. . . . .	20
2.8	Scheme including deployed femtocells, picocells, relays and RRH [54].	23
2.9	Conceptual scheme of the main 5G foreseen features. . . . .	25
3.1	SON categories scheme and typical uses cases in relation with the different phases of a cellular network (based on original figure of [81]).	32
3.2	BeFEMTO architecture. . . . .	35
3.3	Faulty/victim cell example. . . . .	37
3.4	General network monitoring and self-healing scheme. . . . .	39
3.5	Macrocell outdoor and small-cell indoor scenarios. . . . .	51
3.6	Example of statistical differences between cases based on context- information. . . . .	54
4.1	Sources, challenges and main variables for a cellular-context integra- tion scheme. . . . .	62



4.2	Functional OAM Architecture. . . . .	67
4.3	Proposed OAM Architecture implementation for LTE/LTE-A femto-cells. . . . .	72
4.4	PTS/LPTS algorithms scheme. . . . .	74
4.5	Fuzzy logic controller general scheme. . . . .	75
4.6	FLC membership functions. . . . .	77
4.7	Spatial user distributions in the scenario (3 <sup>rd</sup> floor). . . . .	79
4.8	Comparison of impact on performance of a change in the users' distribution for the different optimization and architectural approaches. . . . .	81
4.9	Signaling costs and baseline user plane cell throughput for LTE small cells. . . . .	84
5.1	Context-aware self-healing framework. . . . .	92
5.2	Scheme of classic and proposed context-aware detection/diagnosis algorithm. . . . .	95
5.3	Evolution of indicator RSCP gathered by one terminal. . . . .	98
5.4	Joint Weighted Current Mean RSCP. . . . .	99
5.5	Correlation between indicator contextualized profiles and terminal current measurements distribution. . . . .	100
5.6	Joint Weighted Deviation Mean RSCP. . . . .	100
6.1	Classic and proposed contextualized approaches for the generation of indicators. . . . .	105
6.2	Empirical pdf, histogram and associate approximate normal distribution. . . . .	108
6.3	Classic and proposed approached for the diagnosis inference mechanisms. . . . .	110
6.4	Diagnosis data processing scheme. . . . .	114
6.5	Simulated airport scenario. . . . .	121
6.6	Evolution of classic and contextualized CQI indicators. . . . .	123
6.7	Indicators statistical models. . . . .	126
6.8	Type I / II error and inconclusive rates for the cell 11 case. . . . .	128



6.9	Diagnosis error rate and inconclusive rate for cell 11 failure cases. . .	129
6.10	Diagnosis error and inconclusive rate for different faulty cells. . . . .	130
6.11	Diagnosis error rate given the location error. . . . .	132
7.1	AOIs, sample gathering, and connection between cells. . . . .	139
7.2	Individual stage. . . . .	153
7.3	Distribution, computation, consensus and diagnosis stages. . . . .	154
7.4	Call blocking ratio time evolution for normal and failure periods and different user concentrations. . . . .	156
7.5	Location-based fifth percentile RSRP indicators for different AOIs. . .	157
7.6	FN, FA and IN rates for the cell 11 failure detection. . . . .	158
7.7	Detection performance for different cells in the scenario. . . . .	160
7.8	Detection performance given different location error values. . . . .	161
A.1	Scheme of the LTE system-level simulator functionalities. . . . .	176
A.2	Simulated airport scenario. . . . .	177
A.3	Testbed scenario. . . . .	179
A.4	Testbed entities interaction. . . . .	181
A.5	Testbed SON monitoring GUI. . . . .	181





UNIVERSIDAD  
DE MÁLAGA

# List of Tables

2.1	Cellular main generations and key characteristics [43][45] . . . . .	13
2.2	LTE/LTE-A key characteristics [43][45] . . . . .	18
3.1	Categorization of cellular network problems based on the affected characteristic of the service provision. . . . .	38
3.2	Characteristics of macrocell outdoor and small cell indoor deployments. . . . .	52
4.1	General characteristics of context sources and SON mechanisms. . . . .	59
4.2	3GPP standard OAM layers characteristics. . . . .	66
4.3	Fuzzy rule base. . . . .	76
4.4	JSON UE context report message example. . . . .	83
6.1	Diagnosis evaluation of each method for the cell 11 case. . . . .	128
6.2	Diagnosis error and inconclusive rate values for different faulty cells. . . . .	130
7.1	Required information depending on the AOI calculation approach. . . . .	142
7.2	Sleeping small cell causes and network accessibility . . . . .	150
7.3	Values of the detection performance for different cells. . . . .	159
A.1	System level simulator parameters . . . . .	175
A.2	Testbed elements and parameters. . . . .	180





# Abstract

The last years have seen a continuous increase in the use and capacity of mobile communications. The demand for cellular telecommunication services has grown exponentially pushed forward by the introduction of powerful mobile platforms, flat-rate and huge-allowance data plans, and social and content-distribution applications. In this environment, smartphones and tablets have become the most extended type of mobile platform in many markets. These terminals, equipped with increasingly powerful processing units, operating systems and a huge number of sensors and applications, generate a huge amount of *context information*. Context refers to those variables not directly associated with the telecommunication service itself, but with the terminals and their environment. This includes the user's position, programs/services in execution, terminal model, climate conditions, social data, etc.

With the objective of serving the increasing mobile traffic demand, recently deployed radio technologies, such as Long-Term Evolution (LTE), have led to huge increases in cellular networks capacity. These technologies have also deepened in the adoption of *small cells* (low powered cellular base stations) in order to further improve the cellular network performance. Small cells, thanks to their small coverage areas and reduced deployment costs, allow serving areas with high capacity demand or coverage issues, where classical macrocell deployments can be both unsuccessful or inefficient.

In the current mobile ecosystem, different and new telecommunication systems coexist with legacy ones, including multiple access technologies (GSM, UMTS, LTE / LTE-A), deployment schemes (macrocell, small cells: picocell, femtocells, etc.) and non-cellular communications services (e.g. WiFi), in what has come to be called *heterogeneous networks* (HetNets), also sometimes referred as *heterogeneous and small cell networks* (HetSNets).

Due to the huge complexity of current HetNets, their *operation, administration and management* (OAM) became increasingly difficult. Classic OAM tasks are mainly based on human analysis of the network performance indicators and



alarms and the manual configuration of the network elements. Such an approach turned to be impractical and too costly, due to the enormous number of elements and the heterogeneity of current cellular systems. To overcome this challenge, the Next Generation Mobile Networks (NGMN) Alliance and the 3rd Generation Partnership Project (3GPP) defined the paradigm of *Self-Organizing Network* (SON). SON aims to automate the OAM procedures to minimize their operational costs and increase the service performance. SON encompasses three main functionalities: *self-configuration*, about the plug&play capabilities of the network elements; *self-optimization*, on the continuous re-configuration of the system to adapt to the variable conditions of the service demand; and *self-healing*, dedicated to the failure management and maintenance of the network, including the detection of problems, the diagnosis of their causes, their compensation and recovery.

Cells failure management typically implies sending field engineers to the site, huge costs, long recovery times and important impacts in the service provision and operators' brand-image. Thus, self-healing is of key importance for cellular networks, being the main focus of this thesis and its associated publications.

Till recently, the mechanisms applied to implement the different SON functionalities have been typically based on the analysis of alarms and network performance indicators (e.g. blocked-call rate). However, this approach has become very limited to work with the complexity of the new mobile scenarios and, in particular, for *indoor cellular environments*.

Indoor areas, such as airports, malls and large offices, concentrate the most part of the mobile traffic. Here, the increasing deployment of small cells, their coexistence with multiple telecommunications systems (macrocells, WiFi, etc.) and the intrinsic nature of those scenarios (in terms of propagation and users' mobility) introduce very challenging conditions for network analysis, e.g. very dynamic users' distribution, fast-changing performance, coverage overlapping, etc. These characteristics highly diminish the applicability of mechanisms purely-based on network performance like the ones followed by previous SON approaches.

However, the increasing capabilities of the mobile systems allows the application of context information for OAM automatic mechanisms. This leads to what we have denominated as *context-aware SON*, which is the approach proposed and developed in this thesis. To do so, the present report follows a top-down approach. Firstly, the characteristics of new cellular technology deployments are assessed, especially for indoor small cell networks. In those scenarios, the need for context-aware SON is evaluated and considered indispensable.

Secondly, from the previous point, a new cellular architecture is defined to integrate both context information and SON mechanisms in the management plane



of the mobile network. Thus, the specifics of making context information an integral part of cellular OAM/SON are defined from a logical perspective. Also, the real-world implementation of the architecture is also proposed. This is defined as an extension of the existent 3GPP standards, analyzing the characteristics and advantages of such approach.

Thirdly, from the established general SON architecture, a *logical self-healing framework* is defined on top of it. This framework has the objective of supporting the context-aware healing mechanism to be developed.

Fourthly, different self-healing algorithms are defined depending on the failures to be managed and the conditions of the considered scenario. The developed approaches are based on probabilistic analysis, making use of both context and network data for detection and diagnosis of cellular issues. The conditions for the real-world implementation of these methods are assessed. Finally, their applicability is evaluated by means of system level simulators and testbed trials. The results show important improvements in performance and capabilities in comparison to previous methods, demonstrating the relevance of the proposed approach.



UNIVERSIDAD  
DE MÁLAGA

# Resumen

Los últimos años han visto un aumento continuo en el uso y la capacidad de las comunicaciones móviles. La demanda de servicios de telecomunicaciones celulares ha crecido exponencialmente impulsado por la introducción de potentes plataformas móviles, servicios comerciales de tarifa plana o con límites de capacidad muy elevados, el uso de redes sociales y distribución de contenido multimedia. En este entorno, los teléfonos inteligentes (*smartphones*) y las *tablets* se han convertido en el tipo de plataforma móvil más extendida en muchos mercados. Estos terminales, equipados con unidades de procesamiento y sistemas operativos cada vez más potentes y poseedores de un gran número de sensores y aplicaciones, generan una gran cantidad de *información de contexto*. El contexto se refiere a aquellas variables que no están relacionadas directamente con el propio servicio de telecomunicaciones, sino con los terminales y su entorno. Esto incluye la posición, los programas/servicios en ejecución, el modelo del terminal, las condiciones climáticas, datos sociales, etc.

Con el objetivo de atender a la creciente demanda de tráfico móvil, nuevas tecnologías radio, como *Long-Term Evolution* (LTE) han dado lugar a un enorme aumento en la capacidad de las redes celulares. Estas tecnologías han profundizado en la adopción de *celdas pequeñas* (*small cells* en inglés) consistentes en estaciones base celulares de baja potencia usadas con el fin de mejorar el rendimiento de la red. Las celdas pequeñas, gracias a su reducido coste, áreas de cobertura limitadas y fácil despliegue, permiten proveer a zonas con gran demanda de capacidad o con problemas de cobertura, que los despliegues de macroceldas clásicos pueden ser incapaces de cubrir o no ser rentables.

En el ecosistema móvil actual, nuevos sistemas de telecomunicaciones conviven con sistemas preexistentes, incluyendo así múltiples tecnologías de acceso (GSM, UMTS, LTE/LTE-A), modos de despliegue (macroceldas y celdas pequeñas de diferente tipo: picoceldas, femtoceldas, etc.) y servicios de comunicaciones no-celulares (por ejemplo WiFi), dando lugar a las llamadas *redes heterogéneas* (*heterogeneous networks*, HetNets), también denominadas a veces como *redes celulares heterogéneas y de celdas pequeñas* (*heterogeneous and small cell networks*, HetSNets).



Debido a la enorme complejidad de las redes heterogéneas, su operación, administración y gestión (*operation, administration and management*, OAM) se hace cada vez más difícil. Los enfoques clásicos se basan principalmente en el análisis humano de indicadores de rendimiento y alarmas y la configuración manual de cada elemento de red. Este enfoque resulta ser poco práctico y terriblemente costoso dado el gran número de elementos de red y la heterogeneidad de las redes actuales. Para superar este reto, la *Next Generation Mobile Networks* (NGMN) *Alliance* y el *3rd Generation Partnership Project* (3GPP) definieron el paradigma de *red auto-organizada* (*Self-Organizing Network*, SON). El objetivo de SON es automatizar los procedimientos de OAM para minimizar sus costes operativos y aumentar el rendimiento del servicio. SON abarca tres funciones principales: *auto-configuración* (*self-configuration*), sobre las capacidades plug & play de los elementos de la red; *auto-optimización* (*self-optimization*), sobre la reconfiguración continua del sistema para adaptarse a las condiciones variables de la demanda de servicio; y *auto-curación* (*self-healing*), dedicada a la gestión de fallos y mantenimiento de la red, incluyendo la detección de problemas, el diagnóstico de sus causas, su compensación y recuperación.

La gestión de fallos en las celdas de la red normalmente implica el envío de ingenieros de campo a las estaciones base, con los consiguientes costes, tiempos de recuperación prolongados e impacto en la prestación de servicio y la imagen de marca de los operadores. Por lo tanto, la auto-curación es de vital importancia para las redes celulares, siendo el principal objetivo de esta tesis y sus publicaciones asociadas.

Hasta hace poco, los mecanismos aplicados para poner en práctica las diferentes funcionalidades SON típicamente se han basado en el análisis de alarmas e indicadores de rendimiento de red (por ejemplo, la tasa de llamadas bloqueadas). Sin embargo, este enfoque se ha vuelto extraordinariamente limitado a la hora de hacer frente a la complejidad de los nuevos escenarios móviles y, en particular, para los *entornos celulares de interior*.

Las zonas de interior, tales como aeropuertos, centros comerciales y grandes oficinas, concentran la mayor parte del tráfico móvil. Aquí, la creciente implantación de celdas pequeñas, su coexistencia con múltiples sistemas de telecomunicaciones (macrocelas, WiFi, etc.) y la naturaleza intrínseca de esos escenarios (en términos de propagación y movilidad de los usuarios) introduce condiciones muy exigentes para el análisis de la red, por ejemplo, la distribución de los usuarios es muy dinámica, el rendimiento cambia rápidamente, las coberturas se solapan, etc. Estas características disminuyen la aplicabilidad de los mecanismos puramente basados en el rendimiento de la red como los seguidos por anteriores enfoques SON.

Sin embargo, el aumento de las capacidades de los sistemas móviles permite a la aplicación de la información de contexto a los mecanismos automáticos de

OAM. Esto conduce a lo que se ha denominado como *SON sensible al contexto* (*context-aware SON*), siendo éste el enfoque que propone y desarrolla esta tesis. Para ello, el presente documento sigue un enfoque de arriba hacia abajo. En primer lugar, se evalúan las características de las nuevas implementaciones de tecnología de telefonía móvil, especialmente para las redes de celdas pequeñas de interior. En estos escenarios, la necesidad para SON sensible al contexto se evalúa y se considera indispensable.

En segundo lugar, a partir del punto anterior, se define una nueva arquitectura celular con el objetivo de integrar la información de contexto y los mecanismos SON en el plano de gestión de la red móvil. De este modo, se establece desde una perspectiva lógica las especificidades del uso de información de contexto como una parte integral del sistema OAM/SON. Además, la aplicación de esta arquitectura al mundo real es también definida como una extensión de los estándares 3GPP existentes, evaluándose las características y ventajas del enfoque propuesto.

En tercer lugar, desde la arquitectura general establecida para SON, se define un *marco lógico para auto-curación* (*logical self-healing framework*) por encima del mismo. Este marco tiene el objetivo de apoyar mecanismos específicos de auto-curación basado en contexto a desarrollar.

En cuarto lugar, se proponen diferentes algoritmos de auto-curación en función de los fallos a gestionar y las condiciones del escenario considerado. Los enfoques desarrollados se basan en el análisis probabilístico, haciendo uso tanto de datos de red como de contexto para la detección y el diagnóstico de problemas de celulares. También se definen las condiciones para la implementación en el mundo real de estos métodos. Por último, se evalúa su aplicabilidad por medio de simuladores de nivel de sistema y bancos de pruebas reales. Los resultados muestran importantes mejoras en desempeño en comparación con métodos anteriores, lo que demuestra la relevancia del enfoque propuesto.



UNIVERSIDAD  
DE MÁLAGA

# Acronyms

<b>3GPP</b>	3rd Generation Partnership Project
<b>ACM</b>	Adaptive Coding and Modulation
<b>ADSL</b>	Asymmetric digital subscriber line
<b>AMBR</b>	Aggregate Maximum Bit Rate
<b>AMPS</b>	Advanced Mobile Phone System
<b>ANR</b>	Automatic Neighbour Relation
<b>API</b>	Application Program Interface
<b>APN</b>	Access Point Name
<b>AS</b>	Access Stratum
<b>avg.</b>	Average
<b>BS</b>	Base station
<b>BW</b>	Bandwidth
<b>CAPEX</b>	CApital EXpenditures
<b>CBR</b>	Call Blocking Ratio
<b>COC</b>	Cell Outage Compensation
<b>CQI</b>	Channel Quality Indicator
<b>CS</b>	Context source
<b>CSFB</b>	Circuit Switched Fallback
<b>CSG</b>	Closed Subscriber Groups



---

<b>D2D</b>	Device-to-device communications
<b>DenseNets</b>	Dense Networks
<b>DL</b>	Downlink
<b>DSL</b>	Digital subscriber line
<b>E2E</b>	End-to-end
<b>EDGE</b>	Enhanced Data rates for GSM Evolution
<b>EPC</b>	Evolved Packet Core
<b>epdf</b>	Empirical probability density function
<b>ES</b>	Enterprise Systems
<b>ETWS</b>	Earthquake and Tsunami Warning System
<b>E-UTRAN</b>	Evolved UTRAN
<b>FAP</b>	Femtocell Access Point
<b>FP7</b>	Seventh Framework Programme, European Union research and development funding programme
<b>GNSS</b>	Global Navigation Satellite System
<b>GSM</b>	Global System for Mobile Communications, originally Groupe Spécial Mobile
<b>GW</b>	Gateway
<b>H2H</b>	Human-to-human
<b>HetNets</b>	Heterogeneous Networks
<b>HetSNets</b>	Heterogeneous and Small cell Networks (HetSNets)
<b>HO</b>	Handover
<b>HSPA</b>	High-Speed Packet Access
<b>HW</b>	Hardware
<b>IATA</b>	International Air Transport Association



---

<b>IoT</b>	Internet-of-Things
<b>IP</b>	Internet Protocol
<b>JMS</b>	Java Message Service
<b>JSON</b>	JavaScript Object Notation
<b>KPI</b>	Key Performance Indicator
<b>LAN</b>	Local Area Network
<b>LBS</b>	Location-based services
<b>LIPA</b>	Local IP Access
<b>LLC</b>	Link Layer Control
<b>LTE</b>	Long Term Evolution
<b>LTE-A</b>	Long Term Evolution - Advanced
<b>M.Sc.</b>	Master of Science degree
<b>MAC</b>	Media Access Control
<b>MAP</b>	Maximum a posteriori
<b>MDT</b>	Minimization of drive tests
<b>MIMO</b>	Multiple-Input and Multiple-Output
<b>MLB</b>	Mobility Load Balancing
<b>MME</b>	Mobility Management Entity
<b>M/R</b>	Monitoring and reporting functions
<b>MRO</b>	Mobility Robustness Optimization
<b>MTC</b>	Machine Type Communications
<b>NAS</b>	Non-Access Stratum
<b>NAT</b>	Network Address Translation
<b>NETACC</b>	NETwork ACCessibility
<b>NFC</b>	Near-field communications



---

<b>NGNM</b>	Next Generation Mobile Networks
<b>NMLS</b>	Network Management Layer Service
<b>NMT</b>	Nordic Mobile Telephone
<b>OAM</b>	Operations, Administration and Management
<b>OAMP</b>	Operations, Administration, Management and Provisioning
<b>OCAS</b>	OAM Context-Aware System
<b>OFDMA</b>	Orthogonal Frequency-Division Multiple Access
<b>OPEX</b>	OPERational EXpenditures
<b>OR</b>	Outage Ratio
<b>PAPR</b>	Peak-to-Average Power Ratio
<b>PBGT</b>	Power budget
<b>PCI</b>	Physical Cell ID
<b>pdf</b>	Probability density function
<b>PDN</b>	Packet Data Network
<b>PEP</b>	Performance enhancing proxy
<b>Ph.D.</b>	Doctor of Philosophy
<b>PLMN</b>	Public Land Mobile Network
<b>PPP</b>	Public Private Partnership
<b>QCI</b>	QoS Class Identifier
<b>QoE</b>	Quality of Experience
<b>QoS</b>	Quality of Service
<b>RAN</b>	Radio Access Network
<b>RAT</b>	Radio Access Technology
<b>RE</b>	Resource Element
<b>RF</b>	Radio frequency



<b>RMSE</b>	Root mean squared error
<b>RRM</b>	Radio Resource Management
<b>RSCP</b>	Received Signal Code Power
<b>RSRP</b>	Reference Signal Receive Power
<b>RSS</b>	Received Signal Strength indication
<b>SC</b>	Scrambling Code
<b>SC-FDMA</b>	Single-Carrier FDMA
<b>S-GW</b>	Serving GW
<b>SINR</b>	Signal-to-interference-plus-noise ratio
<b>SIPTO</b>	Selected IP Traffic Offload
<b>SMS</b>	Short Message Service
<b>SW</b>	Software
<b>TR</b>	Technical Recommendation
<b>TS</b>	Technical Specification
<b>UL</b>	Uplink
<b>UMTS</b>	Universal Mobile Telephone Service
<b>UTRAN</b>	Universal Terrestrial Radio Access Network
<b>UUR</b>	Unsatisfied User Ratio
<b>V2V</b>	Vehicle-to-vehicle
<b>WCDMA</b>	Wideband Code Division Multiple Access
<b>WiFi</b>	Wireless Fidelity
<b>XML</b>	Extensible Markup Language



UNIVERSIDAD  
DE MÁLAGA

# Part I

## Background



UNIVERSIDAD  
DE MÁLAGA

# Chapter 1

## Introduction

### Content

---

1.1	Motivation . . . . .	3
1.2	Preliminaries . . . . .	6
1.3	Objectives . . . . .	7
1.4	Thesis structure . . . . .	9

---

This chapter aims to describe the motivation and purpose of this thesis, to present its preliminaries and objectives and to describe the organization of this document.

### 1.1 Motivation

Recent times have seen a complete revolution in mobile communication paradigms. First, smartphones and tablets have achieved a huge penetration in the market, becoming one of the most extended type of terminal [25]. Second, the introduction of flat rate data plans and the continuous increase in connection speeds have pushed the operators to struggle to achieve better performance while narrowing capital and operational expenditures (CAPEX and OPEX).

Along these years, different standards for the *radio access technology* (RAT) and the network architecture have been developed to cope with the increasing demand: *Global System for Mobile Communications* (GSM), *Universal Mobile Telecommunications System* (UMTS), *Long Term Evolution* (LTE), etc. Most of the time, the introduction of each new technology does not imply the removal of legacy systems,



but their coexistence in the same areas. In this way, multiple standards serve the same terminals in each area depending on the specific coverage and service conditions of the terminals at each moment. For example, GSM typically provides wider coverage areas, supporting call services where the coverage of more recent technologies does not reach due to the trend of using increasingly higher frequencies or its limited implementation. Also in LTE, some services have been typically transferred to the coexisting 2G/3G network (e.g. circuit-switched fallback - CSFB). Additionally, other non-cellular technologies, such as WiFi, are also widely available and extensively used by smartphone users, being also object of further integration with the operators' networks (e.g. WiFi offloading [26]).

Also, classic networks were defined solely on the use of macrocells (large base stations with coverage in the range of kilometers or hundreds of meters). However, the need to efficiently provide coverage indoors and in shadow areas, as well as to support the always increasing demand in specific hotspots, has led to the adoption of *small cells*.

Small cells are low-powered base stations with limited coverage (e.g. dozens of meters) that allow increased frequency reuse, providing additional coverage and capacity to specific small areas [27]. Distinct types of small cells have been defined depending on their characteristics and use cases. In indoor scenarios two main types of small cells are defined. Firstly, *picocells*, which are defined as equivalent to normal cellular stations but with reduced coverage. Secondly *femtocells*, also known as *femtocell access points* (FAPs), base stations of reduced capacity connected to the operator's core through non-dedicated backhaul (e.g. DSL) and commonly limited to a reduced number of simultaneous users (typically in the range of 4 to 16).

The simultaneous presence of several deployment schemes (small cell and macrocell) as well as other communication technologies (e.g. WiFi) in the same areas composes what has been called *heterogeneous networks* (HetNets), sometimes also referred as HetSNets (Heterogeneous and Small cell Networks). The complexity, extension and massive number of factors that might impact the performance of HetNets make almost impracticable to manage them by direct human actions/configuration. Therefore, in order to cope with this increasing complexity of the mobile communications infrastructure, the *Next Generation Mobile Networks* (NGMN) Alliance and the *3rd Generation Partnership Project* (3GPP) defined the *Self-Organizing Network* (SON) paradigm [28]. SON aims to improve network performance at reduced costs by automating network *operation, administration and management* (OAM) tasks minimizing the need for human intervention. SON focuses on three major features: *self-configuration, self-optimization* and *self-healing*.

In particular, self-healing refers to automatic *fault management* or *troubleshooting*. In this way, self-healing includes fault detection, root cause analysis (diagnosis),



compensation and recovery. Despite being one of the key factors to keep the quality of service (QoS), self-healing has been scarcely analyzed in the literature, partly due to the intrinsic difficulties of network failure identification in such a complex system as a cellular network. Also, until now, studies in self-healing have been mainly centered on the analysis of macrocell scenarios [29][30][31][32].

However, new challenges greatly impact the application of self-healing in current deployments. Small cells are more prone to failures due to the cheaper, smaller-size, and limited capacity of their equipment, unplanned or careless configuration and higher accessibility to unintentional or even intentional damage.

Classic SON mechanisms are based on alarms, counters and *Key Performance Indicators* (KPIs) [33]. The effectiveness of this approach is limited due to multiple factors that can mask network issues. Overlapping cell coverage areas (between small cells and with the macrocells and with other technologies such as WiFi) [34][35][36][37][38] (typical from HetNets deployments) might avoid the proper detection and diagnosis of network failures for long periods of time. Also, the highly variable distributions of the terminals in the small cell coverages, as their reduced areas (in the range of dozens of meters) imply fast variations in cell occupation that highly reduce the capability of classic indicators to provide a correct understanding of the cell status.

Conversely, the wide penetration of smartphones and tablets in the market enlarges the amount of distributed sensing and computational capacity in the network. New mobile terminals are powerful platforms highly equipped with sensors and applications that increase the availability of terminals and users' *context information* [39][40]. Context encompasses those variables that not directly belong to the telecommunication network but that can be dependent or might impact its performance. This include those variables reflecting the user conditions (e.g. their location, activity, applications) as well as environmental ones (e.g. weather). The increasing availability of context sources opens the way to make use of this type of data for network OAM purposes.

*User equipment* (UE) context data could therefore be included as a new source of information for self-healing, where such solutions are especially promising in the field of indoor deployments of small cells. In this respect, UE context data related to the users' services, activity, consumption, applications and, especially, location would be an invaluable source of support to overcome the described challenges for self-healing at indoor scenarios. The application of context data for general SON procedures, especially optimization, has just started to be investigated in recent times [36][37][38], whereas its application in indoor small cells self-healing procedures has been mainly neglected until now.

Therefore, the present thesis centers on the application of context information for OAM-SON procedures at indoor mobile cellular networks, particularly focusing on self-healing.

## 1.2 Preliminaries

This thesis was carried out at the *Mobile Network Optimization Group* (MOBILENET) of Universidad de Málaga, belonging to the Ingeniería de Comunicaciones group (GIC, TIC-102). This research team is dedicated to the improvement of current and to the design of future mobile telecommunications networks, especially by the development of novel SON techniques. The MOBILENET group originated in 2000 in a collaboration of the GIC with Nokia Networks to create a Research Center for Mobile Communications, established at the *Parque Tecnológico de Andalucía* (PTA) in Málaga, whose personnel included experienced Nokia staff, as well as more than 50 employees and lecturers from the GIC. One of the starting projects for this collaboration consisted on the development of an automatic troubleshooting tool for *radio access networks* (RANs), which established some of the basis for the incorporation of real cellular network data and engineers experience into automatic troubleshooting systems.

Since the beginning, MOBILENET has been working in close terms with the mobile industry operators and manufacturers, collaborating in the advancement of SON techniques in multiple projects. In 2005, the EUREKA CELTIC project “Gandalf: Monitoring and self-tuning of RRM parameters in a multi-system network” began, including France Telecom R&D, Ericsson, the University of Limerick, Telefónica R&D, Moltsen Intelligence Software and the University of Málaga. The project addressed automatic diagnosis and optimization of the *radio resource management* (RRM) in multi-system cellular networks, having as a result a commercial troubleshooting tool.

As part of some projects carried out by MOBILENET, a multi-RAT system level simulator was developed [41]. This simulator included a detailed radio-propagation model, outdoor/indoor environments, macrocells/small cells, user mobility, different modulations, coding schemes and schedulers and additional radio resource management. To model the proper characteristics of small cell failures as well as the management and use of UE context data, this simulator was further extended and completed during the development of the present thesis by its author.

In 2011, the MONOLOC project [42] started funded by the Ministry of Economy and Competitiveness within the National Plan for Scientific Research, Technological Development and Innovation 2008-2011 (record IPT-2011-1272-430000) and the Eu-

ropean Development Fund (ERDF). The project consortium included Universidad Politécnica de Madrid, Universidad Carlos III de Madrid, and the companies INNOVATI and Alcatel-Lucent. It focused on the development of cellular-based indoor localization as well as its integration with SON mechanisms. It was during the development of this project, where most of the present thesis research was performed. The pre-existing MOBILENET system level simulator was extended to include more refined indoor scenarios, different network failures, modeled localization sources and specific context-aware algorithms. A real prototype platform for the management of mobile heterogeneous networks was also developed and deployed. It included the management of multiple femtocells in a large office area supported by UE context reporting and radio fingerprint-based localization. In that platform, the author collaborated in the implementation of the SON module and developed its self-healing components.

After the end of the MONOLOC project in March 2014, the author joined the project *Optimi-Ericsson*, Junta de Andalucía (Agencia IDEA, Consejería de Ciencia, Innovación y Empresa, ref. 59288). This position allowed him to further extend his research work beyond the content of this thesis as well as to gain additional insight on the procedures and technologies being applied in cutting-edge commercial networks.

### 1.3 Objectives

The goal of this thesis is the integration of context information in SON, and particularly self-healing, considering the special characteristics of indoor small cell scenarios. To develop the proposed study, a *top-down approach* is followed, where the analysis goes from the technical overview of the cellular network, through the details for context integration with general OAM/SON systems, to the detailed definition and development of specific self-healing mechanisms (see Figure 1.1).

In this way, the main objectives can be summarized as:

1. **Characterization of cellular technologies:** Given the novelty of the most recent cellular standards (e.g. LTE) and small cell deployments, a detailed characterization of their features is required in order to support posterior developments. Their assessment should cover from the general cellular technology principles to a detailed analysis of the characteristics to be considered in the development of the context-based OAM/SON procedures.
2. **Definition of scenarios and applications of context-aware SON,** encompassing the conditions and requisites where context information should be applied to assist and improve OAM procedures.



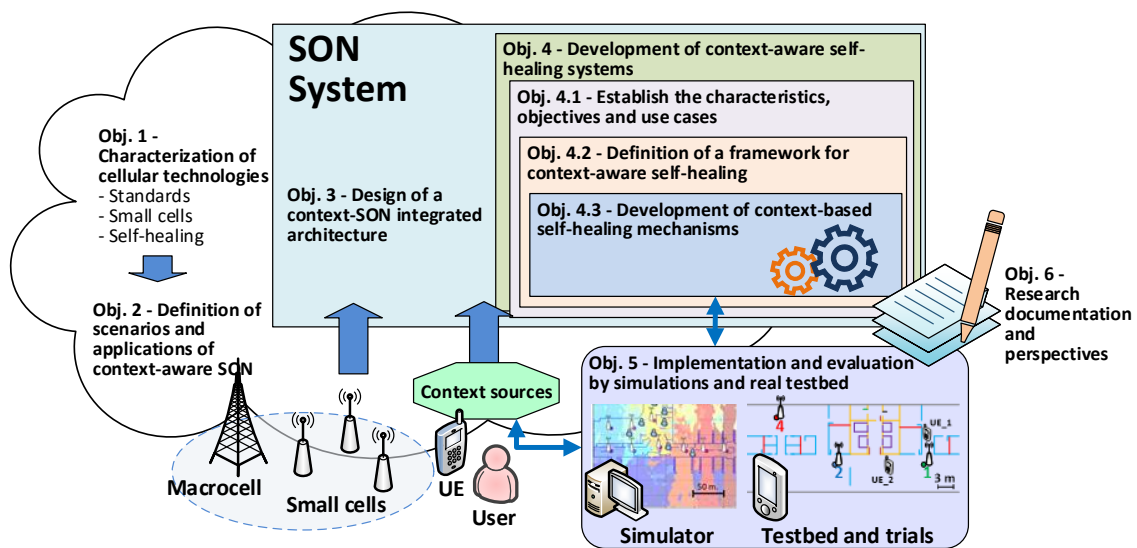

Figure 1.1: Conceptual scheme of the objectives addressed in the thesis.

3. **Design of a context-SON integrated architecture** capable of supporting the joint use of cellular network data and multiple context sources. As such architectures have not been properly addressed in the past, their definition is indispensable to support specific mechanisms. The opportunities for the use of OAM/SON information and procedures to support context sources (e.g. radio-based localization applications) should be also considered. The architectural developments should cover the definition of the functional scheme for context-aware SON, as well as models for its physical implementation in real environments.
4. **Development of context-aware self-healing systems** that should be able to improve the performance of previous approaches. From this, different sub-objectives are identified:
  - 4.1. *Establish the characteristics, objectives and use cases* of self-healing in order to guide and evaluate the specific algorithms and procedures to be developed.
  - 4.2. *Definition of a framework for context-aware self-healing*, this means, the general scheme to integrate context into fault-management systems.
  - 4.3. *Development of context-based self-healing mechanisms*, referring to the specific algorithms and procedures to be defined.
5. **Implementation and evaluation in simulator and real scenario** to analyze the capabilities and performance of the defined mechanisms.

6. **Research documentation and perspectives:** finally, the proper documentation and divulgation of the results of this thesis is another key objective. These would be materialized in this manuscript and the different publications generated from the developed research. These are listed in the “*Summary of contributions*” at the beginning of this report.

## 1.4 Thesis structure

This thesis manuscript observes the same top-down approach followed by the objectives presented in the previous section. In this way, the report is divided in different parts containing multiple chapters as shown in Figure 1.2.

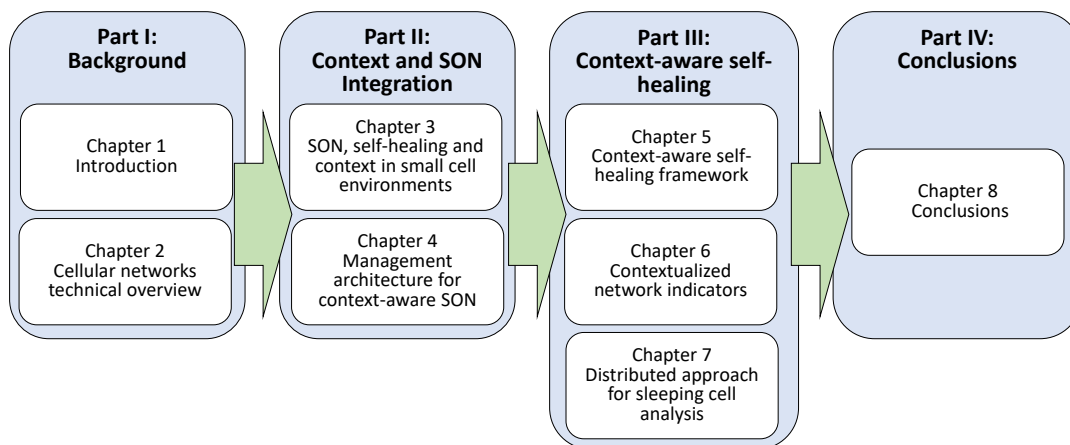

Figure 1.2: Organization of the chapters.

**Part I - Background** presents the preliminaries required for the proper understanding and development of the thesis. This starts with the present introductory Chapter 1. It continues with Chapter 2, which describes the main characteristics of current cellular networks, standards and small cell deployments.

**Part II - Context and SON Integration** deals with the proposed integration of context information in SON and self-healing systems. Firstly, Chapter 3 presents the state of the art of previous SON and context-aware OAM approaches, also assessing the specific characteristics of SON and self-healing in small cell networks. Secondly, Chapter 4 describes the novel architecture defined to integrate context with general OAM/SON cellular systems.

**Part III - Context-aware Self-healing** focuses on the description of the mechanisms developed as part of this thesis. Chapter 5 proposes a self-healing framework

for context-aware self-healing in small cell environments. A use case is proposed to demonstrate the capabilities of the approach in femtocell scenarios, assuming a detailed processing of each UE individual information. Considering picocell-type scenarios with much higher number of UEs, Chapter 6 defines the *contextualized indicators* approach, which combines in the same statistics both context information and network variables. These are applied to different use cases, including both diagnosis (in the same Chapter 6) and distributed detection (in Chapter 7).

**Part IV - Conclusions** consists of Chapter 8, which summarizes the main contributions of the work and sketches the perspectives and future lines of research.

**Appendices:** Appendix A describes the evaluation tools and testbeds used thorough the research. Finally, the summary of the thesis in Spanish is provided in Appendix B.

# Chapter 2

## Cellular networks technical overview

### Content

---

2.1	Cellular standards . . . . .	12
2.2	LTE . . . . .	14
2.2.1	Radio access . . . . .	15
2.2.2	Network architecture . . . . .	17
2.3	OAM reference model . . . . .	20
2.4	Small cells . . . . .	22
2.5	5G perspectives . . . . .	24
2.6	Conclusions of the chapter . . . . .	26

---

This chapter provides a summarized analysis of the cellular technologies considered on this thesis, focusing on their different key aspects. Firstly, the technical characteristics of cellular standards (in Section 2.1) with special detail on LTE (Section 2.2) are introduced. Here, an overview of the historical evolution of the most preminent cellular technologies is presented as a founding stone for the innovations proposed in this thesis. Section 2.3 deepens on the 3GPP baseline OAM model from which the architectural developments of this thesis and particularly the ones proposed in Chapter 4 will build on. The general concepts surrounding indoor small cell deployments are presented in Section 2.4, while the perspectives for 5G future technologies are summarized in Section 2.5. Section 2.6 ends the chapter presenting its conclusions.



## 2.1 Cellular standards

Cellular technologies evolution has been typically categorized in distinct “generations” (referred commonly as XG, being ‘X’ the generation number<sup>1</sup>). Each generation encompasses different standard releases, as the 3GPP<sup>2</sup> ones presented in Figure 2.1. This 3GPP standardization releases encompasses between 1 and 3 years of development [43] as also shown in the figure.

The standards/releases of each generation share a certain set of common characteristics, especially in terms of access protocols, architecture and traffic management capabilities, as presented in Table 2.1. Sometimes more than one technology is con-

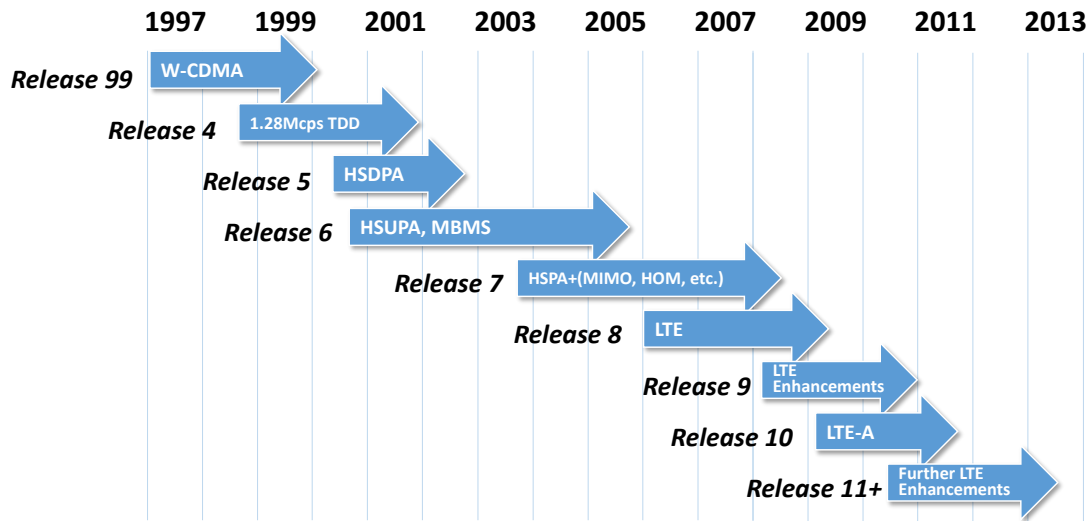

Figure 2.1: 3GPP main standard releases [43].

In terms of their commercialization, telecommunications subscriptions typically allow to access the network using a particular technology (e.g. LTE) with defined consumption limits and fees. The use of older technologies is also included as a fall-back if the most advance system is not available in a certain spot or moment or due

<sup>1</sup>Sometimes intermediate generations, such as 2.5G or 3.5G are defined to indicate transitional steps to posterior developments, relevant additions to the characteristics of the generation or for commercial purposes. Such distinction will be ignored in this report, referring always to the complete generation instead.

<sup>2</sup>3GPP is the main association of telecommunication bodies and standardization groups in charge of the development and maintenance of cellular standards: GSM, UMTS and LTE [43].

to terminal limitations. Figure 2.2 shows the distribution of cellular subscription by technology, following the nomenclature used in [25]. It can be noticed how the most widespread subscriptions by the time of this report (early 2016) are GSM/EDGE, WCDMA<sup>3</sup>/HSPA and LTE.

Table 2.1: Cellular main generations and key characteristics [43][45]

Gen.	Standards <sup>4</sup>	Access protocols	Key features
1G	NMT, AMPS	FDMA	Analog, mainly voice, limited security, support for low bit rate data
2G	GSM, GPRS	TDMA, CDMA	Digital, voice and data, SMS
3G	EDGE, UMTS/HSPA+	CDMA2000, WCDMA, HSDPA, TD-SCDMA	Digital, multimedia, Internet browsing
4G	LTE <sup>5</sup> , LTE-A	OFDMA, SC-FDMA	Data-oriented, low latency, high speed. Renovated architecture.

The main applications and market penetration of each technology are described below:

- **GSM/EDGE:** Beginning its commercialization in the early 90s, GSM was the first standard that could be considered “global” given its level of deployment and market penetration. It introduced *digital* cellular systems, providing voice calls and basic data services. In 2003, a later backwards-compatible technology, *Enhanced Data rates for GSM Evolution* (EDGE), was introduced. Nonetheless, the use of pure GSM/EDGE-only subscriptions still provide very limited data services for current end-user needs. Consequently, this kind of subscriptions is in clear decline (see Figure 2.2). However, the abundance of legacy systems and base stations combined with its common assignment in low bands of the spectrum make GSM/EDGE the most ubiquitous coverage, serving as the main baseline/fallback for more recent technologies.
- **WCDMA/HSPA:** WCDMA is one of the air-interface options of UMTS, which HSPA extended for increased data rates. These technologies currently provide the largest part of the cellular voice and data-traffic worldwide, being extensively implemented in nearly all populated areas.

<sup>3</sup>Here WCDMA refers not to the specific RAT (WCDMA), but to the complete air interface standard used in both UMTS and HSPA networks [44]

<sup>4</sup>Key examples, not a comprehensive list of all standards of the generation.

<sup>5</sup>Although LTE did not officially accomplish the requisites defined by the IMT-Advanced to be considered 4G, it is extensively labeled as such.



- **LTE:** New LTE standards started to be deployed in the early 2010s introducing a renovated IP-based architecture, new access protocols, reduced latency and increased speeds. Currently most countries' operators have already performed extensive deployments, although still focused on the most populated areas.

The term LTE (including its direct evolution such as LTE-A) encompasses the most recent cellular technologies and the ones expected to be the most widespread in the years to come. Therefore, this thesis particularly focuses on the application of its developments in such networks. Taking this into account, the following Section 2.2 provides an analysis of their main characteristics.

### Mobile subscriptions per tecnologia in billions

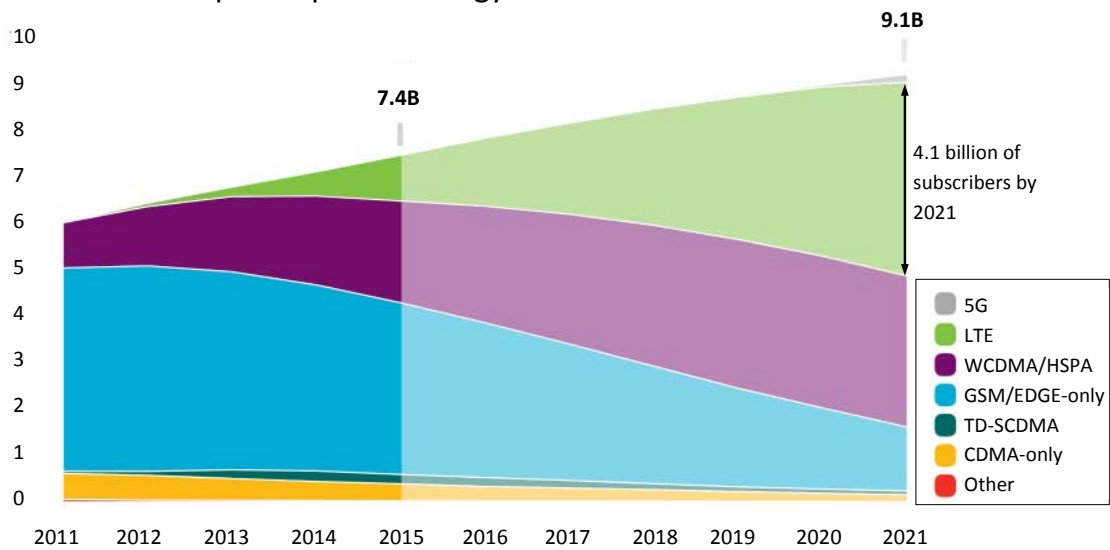

Figure 2.2: Mobile subscriptions by technology (billions) [43].

## 2.2 LTE

The set of LTE standards (sometimes referred as LTE/LTE-A standards or the *LTE family* [46]) have been defined with the objective of supporting the increasing requirements for data services in mobile communications. 3GPP develops the LTE standards, introducing radical innovations in comparison to previous systems.

The release 8 was the first LTE-release, where further enhancements were included in further releases. The later *LTE-Advanced* standard (LTE-A), defined in release 10 onwards, included important architectural and radio access additions to the general framework provided by LTE. Moreover, the label *LTE-Advanced Pro* has

been formulated in release 13, where previous features of LTE became mature, in particular for the support of *machine-type communications* (MTC), *device-to-device* (D2D) communications, WiFi interoperability, etc. (see [47]).

LTE novelties focus on increasing throughput and reducing latency, which leads to a newly defined RAT as described in Section 2.2.1. These technologies also simplify and improve the user and control planes of the cellular network architecture (see Section 2.2.2). For the management plane, LTE/LTE-A follow the high-level 3GPP management architecture common to UMTS and GSM, as it is presented in Section 2.3. LTE also incorporated the SON concept into the standard, as it will be described in Section 3.1.1.

### 2.2.1 Radio access

One of the main characteristics introduced by LTE is the definition of a new air-interface between the UEs and the *base stations* (BSs). Here, *orthogonal frequency-division multiplexing* (OFDM) is adopted as the modulation scheme. OFDM implies higher robustness against multipath, fading and interference, allowing also a better efficiency when making use of spatial multiplexing techniques such as *multiple-input multiple-output* (MIMO).

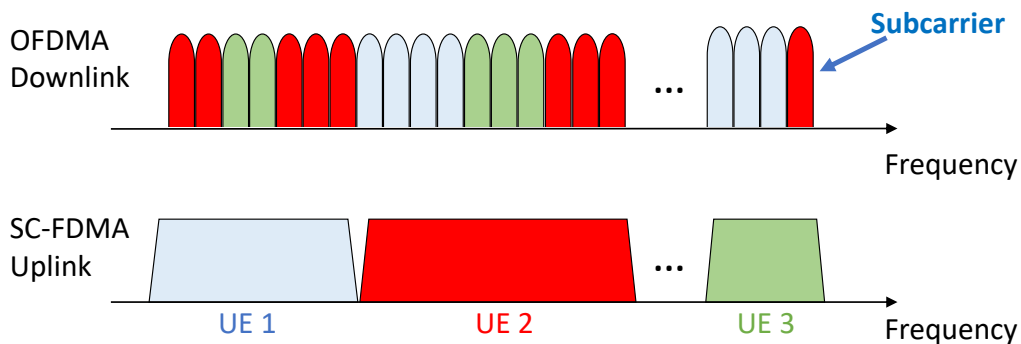

Figure 2.3: LTE access schemes [43].

For the access to the medium, the downlink (transmissions from BS to UEs) uses *orthogonal frequency-division multiple access* (OFDMA). Meanwhile, the uplink (transmissions from the UE to BS) implements *single-carrier frequency-division multiple access* (SC-FDMA), as shown in Figure 2.3.

The allocation of resources in LTE is structured in *resource elements* (REs), consisting in the assignment of one subcarrier (15 kHz) x 1 symbol (see Figure 2.4).

Each symbol has a maximum duration 0.5/7 ms or 0.5/6 ms depending, respectively, if *normal* or *extended* cyclic prefix is used. However, the minimum allocable resource per UE is the *Resource Block* (RB), consisting of 12 subcarriers x 15 kHz = 180 KHz, during one time slot (0.5 ms), equivalent to 6 or 7 OFDM symbols (see Figure 2.4). Apart from user data, each PRB might contain REs dedicated to control and *reference signal* (RS) [48].

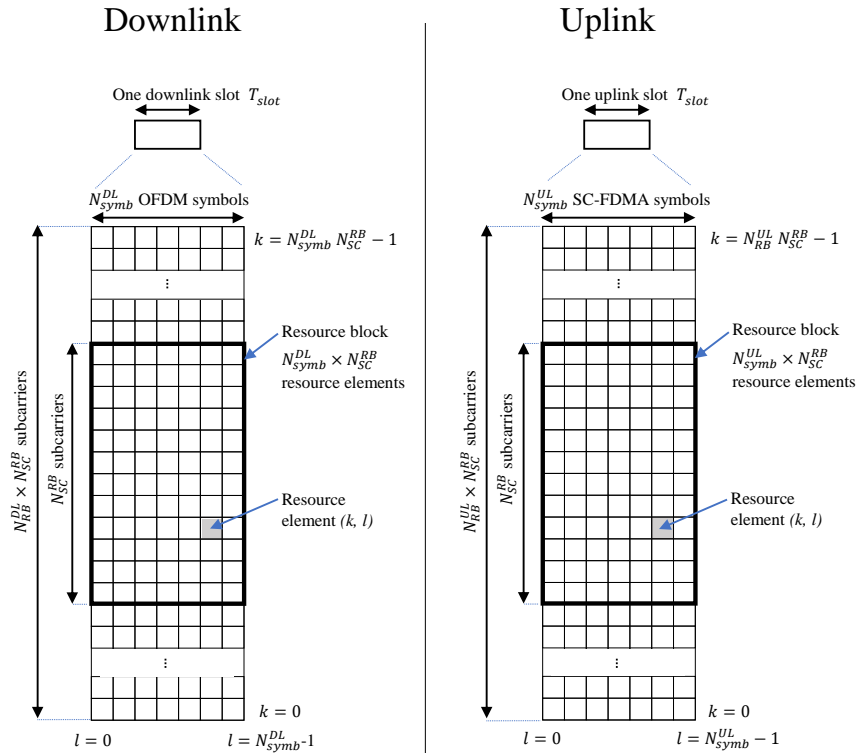

Figure 2.4: REs and RBs in LTE [49].

On the one hand, in the LTE OFDMA downlink, where the RBs assigned to an UE can be discontinuous to each other (see Figure 2.4-left). On the other hand, the uplink makes use of SC-FDMA. SC-FDMA was selected for the uplink as it leads to a *Peak-to-Average Power Ratio* (PAPR) much reduced in comparison with OFDMA, relaxing the linear characteristics of the amplifiers and therefore its cost. This is especially important to minimize the price in the UE side. While in OFDMA each subcarrier transports an independent data stream, in SC-FDMA, each symbol (0.5 ms / 6 or 0.5 ms / 7) expands for all the assigned subcarriers (as shown in Figure 2.3).

LTE-A keeps the main LTE characteristics, adding new functionalities. One of the most important ones is *carrier aggregation*, which allows to assign multiple carriers to each terminal, incrementing the available bandwidth and the versatility of its assignment (see Figure 2.5). The comparison between the general radio characteristics of both LTE and LTE-A can be found in Table 2.2

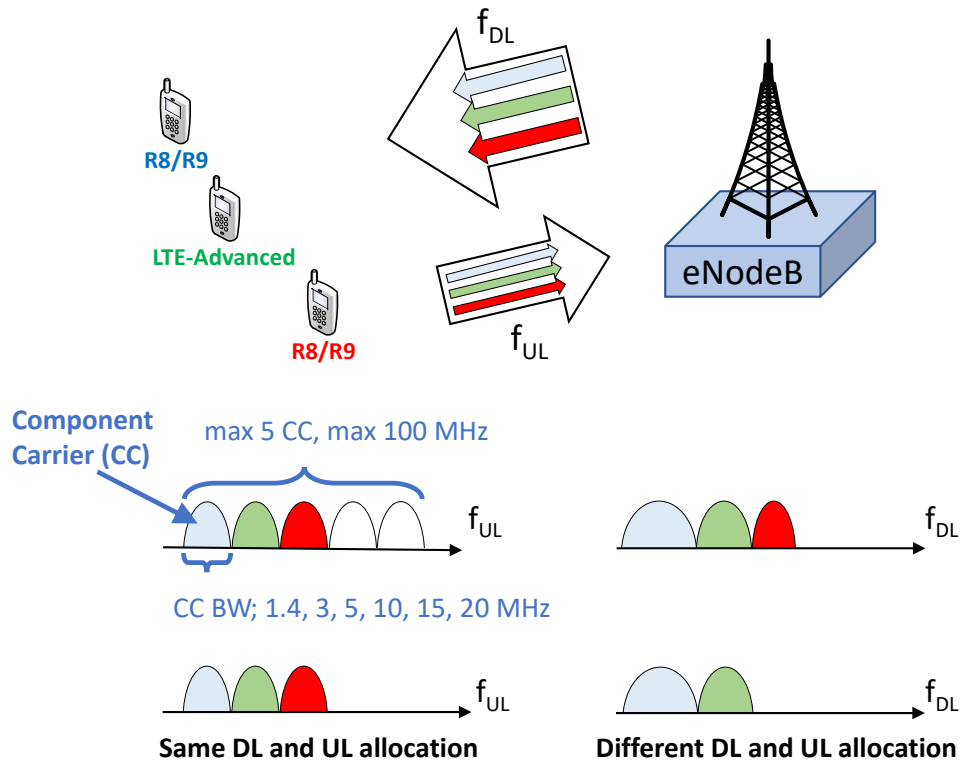

Figure 2.5: Carrier aggregation in LTE-A [43].

## 2.2.2 Network architecture

Another important improvement introduced by LTE is the simplification of the general network architecture and the integration of femtocell base stations [43]. In this subsection, the main LTE architectural elements, interfaces and functionalities are described centering in both the user and control planes. Conversely, the management/OAM plane of LTE is common to previous 3GPP standards and therefore will be detailed later, in Section 2.3.

The LTE architecture presents two main parts. Firstly, the *Evolved UTRAN*

Table 2.2: LTE/LTE-A key characteristics [43][45]

Feature	Link	LTE	LTE-A
Access type	UL	SC-FDMA	
	DL	OFDMA	
Bandwidth		1.4, 3, 5, 10, 15, 20 MHz	Up to 100 MHz
Peak Throughput	UL	75 Mbps	500 Mbps
	DL	300 Mbps(4x4 MIMO) / 150 Mbps (2x2)	1000 Mbps
Minimum TTI		1 ms	
Subcarrier BW		15 kHz	
Modulations		QPSK, 16QAM, 64QAM	
MIMO	UL	Multi-user collaborative MIMO	Up to 4x4
	DL	2x2, 4x4	Up to 8x8

- *Universal Terrestrial Radio Access Network* (E-UTRAN), comprising the radio access for the terminals, the base stations and their interconnection between them and with the rest of the network. Secondly, the *Evolved Packet Core* (EPC), the center of the cellular network, grouping the main elements in charge of routing the voice and data flows, as well as subscription and billing. It also provides the connection to external non-3GPP entities and other operators' networks. In this way, the system follows the scheme presented in Figure 2.6, where its main elements are described below.

The *evolved Node B* (eNB) is the basic LTE element for the functionality associated with the base stations. Its main functionalities are:

- Management of radio resources: control carrier, admission control, connection mobility and UL/DL dynamic resource allocation for the UEs.
- IP header compression and encryption of the users' data flow.
- Association between MME and UEs when it cannot be established with UE info.
- Routing of the user plane data to the S-GW.
- Planning and transmission of paging, broadcast and *Earthquake and Tsunami Warning System* (ETWS) data.
- Monitoring and configuration report for mobility and planning.



terms of users and subscriptions, serving also as support for the mobility management, setups of calls and sessions and authorizations.

- *HeNB gateway* (HeNB-GW), an optional element, serves as a concentrator of the control plane of the HeNBs to reduce the amount of signaling passed to higher elements.

## 2.3 OAM reference model

For the OAM plane (sometimes also referred as OAMP or OAM&P, where the “P” is added to include the *provisioning* of network elements), 3GPP defines its reference model as shown in Figure 2.7, which is common to UMTS/HSPA, LTE and beyond [52].

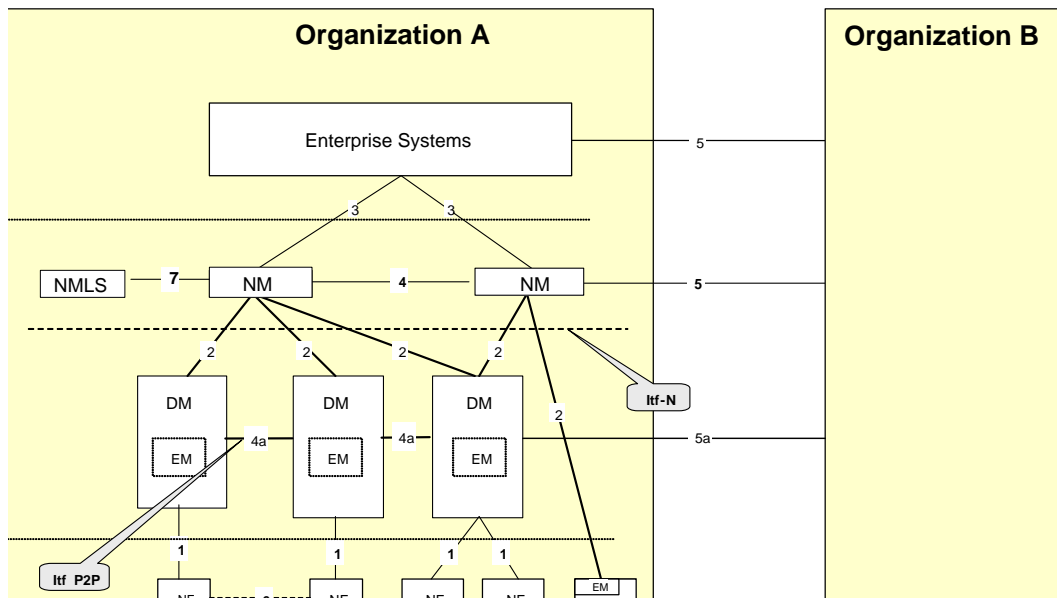

Figure 2.7: Management reference model [52].

This framework follows a hierarchical structure whose main logical elements are the following:

- *Network Element* (NE), which refers to any individual telecommunication entity that can be managed, e.g. an eNB.

- *Element Manager* (EM), which provides a series of end-user (administrator) functions for the management of a set of NEs, where sometimes the EM functionality can reside in the NEs themselves. These management functions can be divided in *element management functions* and *network management functions*, depending of their scope.
- *Domain Manager* (DM), providing management of the elements and domain of a subnetwork. If the DM is an *inter-working DM*, it provides multi-vendor and multi-technology functionalities.
- *Network manager* (NM), giving the functionalities associated with the OAM of a complete network. It would typically work with the entities at EM level, but it might can also manage NEs in a direct manner. All the communication associated with this is based on open interfaces supporting multi-vendor and multi-technology NEs.
- *Network Management Layer Service* (NMLS): logical entity at the NM layer but separated to the general NM functionality. It was originally defined to support *Radio Planning Tool* (RPT), allowing to read antenna and site data information in a standardized manner [53]. The NMLS definition leaves the door open to the implementation of additional applications.
- *Public Land Mobile Network (PLMN) Organisation*, referred often simply as *organisation*, is the legal entity managing a cellular network and providing the telecommunication service.
- *Enterprise systems* (ES): information system used by the operators to manage the aspect not directly related with the telecommunications of the network, e.g. call center, detection of fraud, prevention, invoicing, etc.

The management reference model provides a series of functions and interfaces (numbered in Figure 2.7) for the interaction between the different entities, where the entities themselves are not defined by the 3GPP [52].

Classically most of the OAM activities has been centrally implemented in the *operations and maintenance center* (OMC) also named *operations support system* (OSS) or *operations system* (OS), which consists of the set of computer equipment dedicated to the management of the cellular network, including fault, configuration, performance and inventory management. This element would typically be an external element that would collect data from the different interfaces.

SON and OAM functions can be implemented following this standard basic model, or distributing the functionality of each mechanism between its different

elements. The standard itself includes a reference implementation of a reduced set of specific SON use cases, which are further described in Section 3.1.1.

## 2.4 Small cells

Radio-frequency spectrum has always been a scarce resource for telecommunications operators, where the increasing capacity demand of the mobile users make its need even more stringent.

One of the main approaches to address this challenge consists in increasing the number of network cells, reducing their coverage. In this way, it is possible to increment bandwidth reuse as well as to allocate just the necessary resources to each area, reducing the energy-consumption and the requirements of the overlaid macrocells. As indicated in Section 1.1, this has led to the introduction of reduced-scale, low-powered base stations denominated *small cells*.

Various kinds of small cells have been defined depending on their characteristics and use cases. The nomenclature to denominate each small cell type typically varies between manufacturers. In this situation, this thesis will follow the naming established by the Small Cell Forum [27].

Two main types of small cells can be distinguished. Firstly, those which possess, from an architectural perspective, the same characteristics and functionalities of normal macrocells but with reduced transmitted power, such as microcells (for outdoor) and picocells (for indoor and typically with up to 200 meters of cell area radius).

Secondly, femtocells, which are also low powered based stations (with coverage areas in the order of dozens of meters), but characterized for using non-dedicated general broadband connections (e.g., DSL) to communicate with the rest of the operator's infrastructure. As seen in the previous Section 2.2.2, femtocells are modeled in the LTE standard as HeNB. The HeNB has been defined with special consideration to the use of limited broadband backhaul, the coordination with macrocells and the particularities of its service provision.

Here, femtocells were especially defined for residential and enterprise services, making possible both *open access*, when any operator's subscriber can connect to them; or *close access*, if only a defined-list of terminals can be served by a femtocell.

Additional non-classic cellular coverage-provision systems have also spread out in recent times, especially *relays* and *remote radio heads* (RRHs). On the one hand, relays are systems that retransmit the signal coming from a base station, allowing it to reach specific shadow spots. As they only retransmit the original cellular

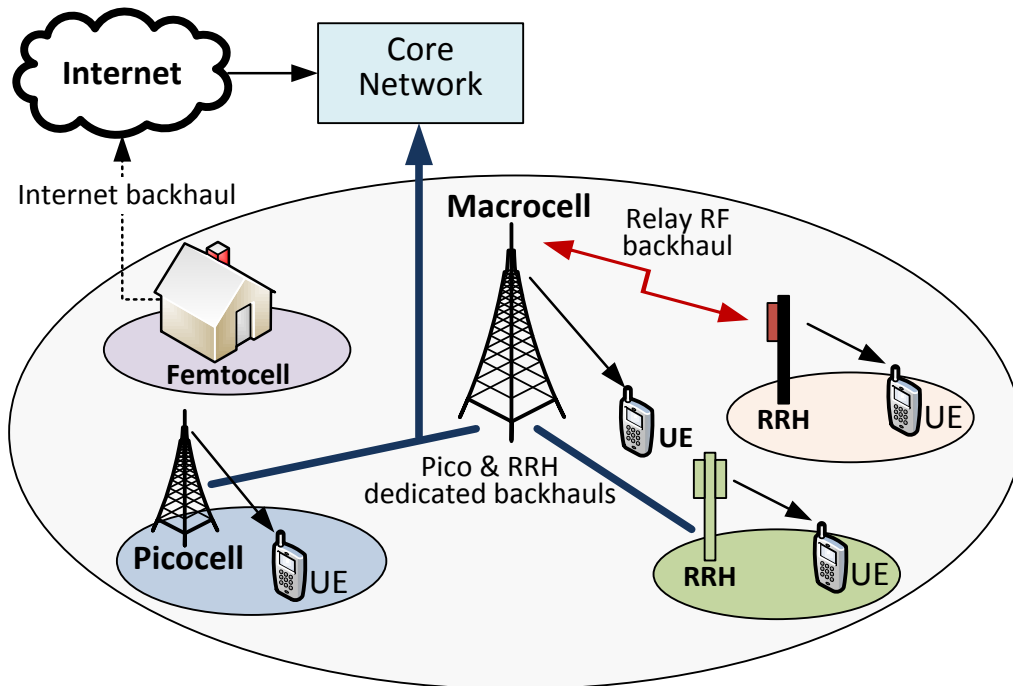

Figure 2.8: Scheme including deployed femtocells, picocells, relays and RRH [54].

emissions, the relays do not possess a cellular identifier, and they are “transparent” for the end UEs.

On the other hand, RRHs consists in transceivers connected to a remote BS (commonly by optic fiber). RRHs perform all the radio related activities of the cell, while upper link layer actions are computed at the BS. RRHs distributed nature allow to centralize computational processes associated with the UEs access and mobility, as well as to facilitate MIMO schemes.

Small cells, relays and RRHs deployment models define a far more heterogeneous environment than in previous macrocell scenarios, as well as to a huge increase in the number of network elements to be managed by operators. Additionally, this trend is expected to continue growing leading more and more to *dense networks* (DenseNets) and *ultra-dense small cell networks* (with a few tens of meters inter-site distance [55]), being one of the main approaches used to reach the upcoming coverage and throughput requirements in 5G standards.

This increasing densification and heterogeneity will make even more indispensable the implementation of efficient SON algorithms for the management of current and future cellular networks.

## 2.5 5G perspectives

Beyond LTE-A, newer technologies and under-development standards, are labeled in a new generation known as 5G. 5G has just recently started to be the focus of research works [56][57] and initial operators' analysis [58].

Also, different international research projects have aimed towards 5G. In the European context, *the 5G Infrastructure Public Private Partnership* (5G - INFRASTRUCTURE - PPP, in short 5G-PPP) is an initiative between the European Commission and industry partners to support future 5G infrastructure and technologies [59]. This initiative serves as an umbrella for several projects addressing different aspects of the 5G requirements and techniques, such as *Fantastic5G: flexible air interface for scalable service delivery within wireless communication networks of the 5th Generation* [60], on the radio access; and *METIS-II: Mobile and wireless communications Enablers for Twenty-twenty (2020) Information Society-II* [61], dedicated to the technical enablers for the 5G radio access network. Also, the H2020 project *One5G: E2E-aware Optimizations and advancements for the Network Edge of 5G New Radio*, started on June 2017, focuses on the development of advanced 5G technologies to tackle the needs of different vertical use cases, to increase capacity and to improve energy-efficiency in dense urban and rural areas [62].

Although 5G technologies are still under definition, current studies focus on three main characteristics of this new generation: converged fiber-wireless, super-efficient and super-fast mobile networks [56]. 5G infrastructure will also focus on obtaining an increased capacity and faster access, virtualized network functions and software upgradeable elements, support to a wide-range of applications and ubiquitous connectivity [59].

To do so, this generation is expected to be a continuation of previous standards, keeping many of their current characteristics but including a deep extension of previously explored and still not fully-developed technologies [63][64], especially (as visually represented in Figure 2.9):

- The operation of the network would become more dynamic, flexible and manageable by adopting a software-based network architecture following the *software-defined networking* (SDN) [65] and *network function virtualization* NFV [66] paradigms.
- *Network slicing* and *user-centric* network models consisting on providing very diverse services capabilities through different virtual radio access networks supported by the same RAT with multiple customizable software-defined functions. In this way, the network will be able to fit its resources specifically to

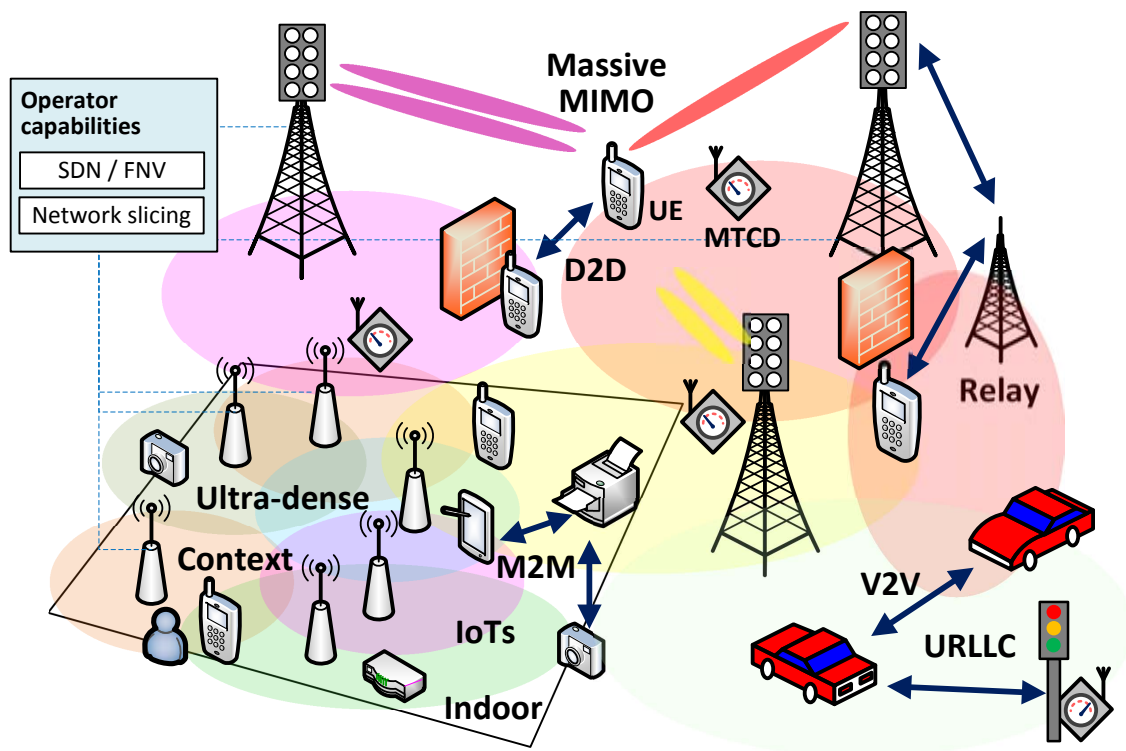

Figure 2.9: Conceptual scheme of the main 5G foreseen features.

distinct types of services and end-users with very divergent needs, such as sensors, smart meters, media services and emergency demand [67].

- Increased capacity is expected to be achieved using higher frequencies (including  $>6$  GHz), massive MIMO and frequency reuse. Those approaches would also push forward the need for ultra-dense networks [55][68], where the increasing number of BSs, relays and antennas would cope with the limited propagation of high frequencies and support MIMO and frequency reuse.
- New mobility schemes, such as *cell-less* systems and user-centric architectures [69], will become common. Mobility will also be hugely impacted by the wider application and further evolution of techniques such as carrier-aggregation [70][71], unlicensed spectrum [72] and multi-connectivity [73][74], as well as for the increasing service requirements [75].

Many of these of these technologies aim at supporting one of the main expected characteristic of 5G technologies as represented in Figure 2.9, the capability to serve

multiple types of traffic, *enhanced Mobile Broadband* (eMBB), *vehicle-to-vehicle* (V2V), *Internet-of-Things* (IoT), *machine type communications* (MTC), *Ultra-Reliable and Low-Latency Communications* (URLLC), etc. The type of connected terminals would be very heterogeneous, including classical *human-to-human* (H2H) UEs, connected vehicles and *MTC-devices* (MTCD)<sup>6</sup>, e.g. sensors, actuators, etc., and their number will increase exponentially, also increasing the availability and variety of context information.

From these features, ultra-dense deployments and context-aware OAM are anticipated as one of the most important approaches to satisfy the upcoming coverage, throughput and management requirements of 5G networks, being also the ones with a most relevant impact in OAM/SON functionalities.

## 2.6 Conclusions of the chapter

This chapter has introduced the main characteristics of current cellular technologies, architecture and OAM reference framework. It has also presented the details on small cell deployment and prospective 5G systems, establishing the interest for the integrated application of context-aware methods in the OAM procedures of both present and future systems, particularly for small cells based ones.

---

<sup>6</sup>Although MTCDs are a special case of UE (dedicated to M2M communications), they are labeled as such in Figure 2.9 as opposed to the general devices (commonly H2H) labeled as “UEs”, following the common nomenclature used for network representations in the bibliography [76][77].

## Part II

# Context and SON integration



UNIVERSIDAD  
DE MÁLAGA

# Chapter 3

## SON, self-healing and context in small cell environments

### Content

---

3.1	Self-organizing networks . . . . .	30
3.1.1	SON in the 3GPP standards . . . . .	32
3.1.2	Related projects . . . . .	33
3.2	Self-healing . . . . .	36
3.2.1	Principles . . . . .	36
3.2.2	General scheme . . . . .	39
3.2.3	Network variables . . . . .	40
3.2.4	State of the art . . . . .	43
3.3	Context . . . . .	48
3.3.1	Related work . . . . .	48
3.3.2	Indoor localization techniques . . . . .	49
3.3.3	Wrap-up . . . . .	50
3.4	Small cell challenges and context-awareness . . . . .	50
3.5	SON-aware context . . . . .	55
3.6	Conclusions of the chapter . . . . .	55

---

This chapter is dedicated to three main objectives. Firstly, it presents the principles and related work on the research fields of this thesis: SON and self-healing. Secondly, it identifies the key context variables for cellular networks, describing the previous works in the field of their application to cellular communications. Thirdly,



it presents and assess the major features and challenges for small cell networks OAM /SON activities, particularly from the perspective of the statistical analysis of its metrics.

In this way, the chapter is organized as follows. Section 3.1 provides an initial introduction to SON, its different categories and summarizes key previous research projects on the topic. Section 3.2 details the principles and proposed scheme for self-healing, while summarizing the state of the art of non-context-aware mechanisms. Section 3.3 establishes the main context variables of interest for cellular networks, identifying the previous works that proposed their use. Section 3.4 revolves around the challenges of small cell scenarios, assessing their characteristics of these deployments and the possibilities to overcome these based on the use of context. Additionally, Section 3.5 summarily analyzes the use of cellular information and SON functions by context sources and user applications. Finally, Section 3.6 presents the conclusions of the chapter.

The analysis perform in this chapter can be found distributed through all the related publications, especially in:

- S. Fortes, A. A. Garcia, J. A. Fernandez-Luque, A. Garrido, and R. Barco, “Context-Aware Self-Healing: User Equipment as the Main Source of Information for Small-Cell Indoor Networks,” *IEEE Vehicular Technology Magazine*, vol. 11, pp. 76–85, March 2016.

## 3.1 Self-organizing networks

As initially described in Chapter 1, SON is the paradigm defined under the auspices of 3GPP [43] and the NGMN Alliance [78] to automate mobile infrastructure OAM. This implies huge advantages, as approximately the 24% of the costs of a mobile operator are typically OPEX, a percentage that increases as the network matures [79]. SON reduces this OPEX through automation of tasks that are currently performed manually and with an important dedication of experienced staff. In addition, SON also helps to reduce CAPEX thanks to a more efficient use of network elements and resources, an extension of the useful life of the equipment and an increased performance of the network. Thus, better coverage, capacity and quality can be obtained with less investment in network elements.

In this way, SON was identified as one of the key design principles for mobile communication networks of future generation [80]. Consequently, 3GPP has developed a standardization effort to define its different use cases.

For SON, three main *functionalities* or *categories* are identified, as presented in Figure 3.1. Each SON category covers different *use cases* or *functions*, that can be implemented by different *mechanisms* / *methods*.

- *Self-configuration*: About the plug and play capabilities of network elements, allowing the quick introduction of new equipment in the system during their deployment. This implies that individual elements can fix their initial parameters, obtain information from their neighbors and/or connect to the general OAM system in an autonomous manner [80]. Some of the main self-configuration use cases include the self-test of the elements, the set-up of the interfaces with the rest of the network entities (e.g. X2 and S1 interfaces) and the automatic download/update and configuration of their software.

Sometimes, self-configuration is assumed to cover also the automatic definition of the number, type and location of the network elements for a new deployment, their radio parameters, the automatic assignment of *Physical Cell ID* (PCI) and *Scrambling Code* (SC) of the cells and others [80][81]. However, those tasks are often considered as part of a different SON functionality, named *self-planning* [82]. For this, *decision supports systems* (DSS) are also envisaged to determine the assist the selection of new NEs and resource deployments.

- *Self-optimization*: For the adjustment of parameters during the *operational life* of the system, adapting it to the dynamic variations in demand and use. Typical self-optimization use cases include *load balancing* (LB) [83], traffic steering [84], handover optimization [85] and energy saving [86].
- *Self-healing*: For automatic failure management of the system, including detection of service problems, diagnosis of their causes, compensation of the effects and recovery of the network failures. Being the focus of the present thesis, a detailed description about self-healing is provided in Section 3.2.

The different SON functions would typically be implemented as part of the OAM architecture, as described in Section 2.3 (in the NE, DM, and NM entities). However, some of their mechanisms might reside closer to the control plane of the network.

As it will be further developed for the self-healing case (see specially Section 3.4), the classic approaches for SON are challenged by the characteristics of small cell deployments, as well as for the increased speed necessary for the SON functions to fully commit to the growing network requirements and users' demands.

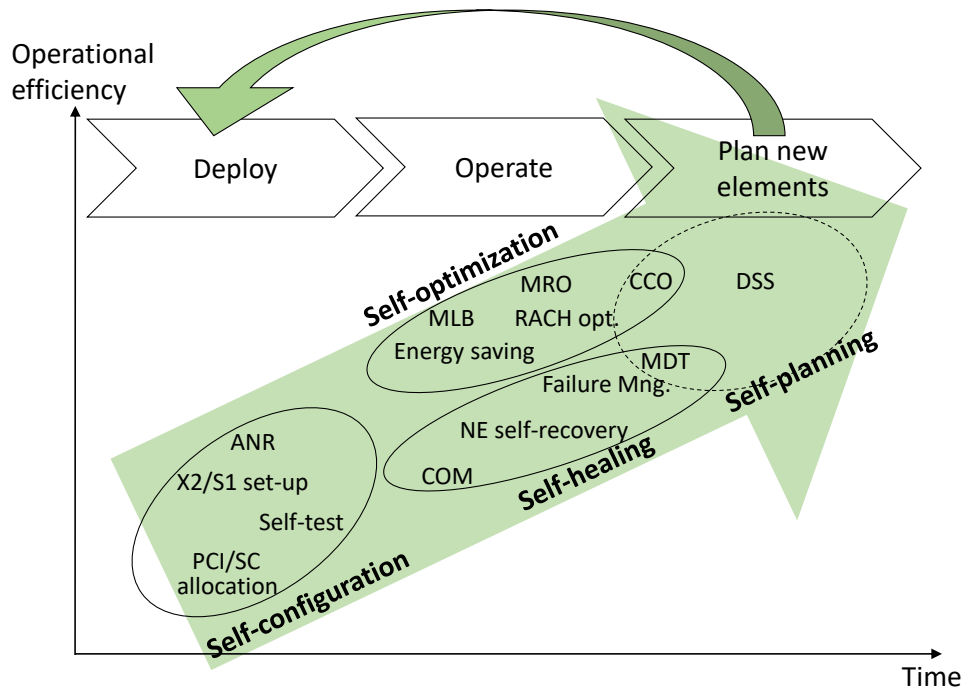

Figure 3.1: SON categories scheme and typical uses cases in relation with the different phases of a cellular network (based on original figure of [81]).

### 3.1.1 SON in the 3GPP standards

3GPP introduced the general SON concept and functions in the LTE standard. This is done in a qualitative manner, without providing implementation details or specific algorithms. In this way, the *technical specification* (TS) 3GPP TS 32.500 [28], provides some general requirements for SON in 3GPP and sketches a couple of high-level use cases: eNB sharing and transition from open loop to closed loop. It also distinguishes between *centralized SON*, for those algorithms executed in the OAM NM or EM elements (see Section 2.3); *distributed SON*, if the algorithms are executed at NE level); or *hybrid SON*, if it has a combination of both.

A high-level description about the involved inputs and expected results is provided for self-configuration, self-planning and self-optimization [87] use cases, such as *coverage and capacity optimization* (CCO), energy savings, *mobility robustness optimization* (MRO), *mobility load balancing optimization* (MLO), RACH optimization (most of these represented in Figure 3.1 diagram). The standard enters in a little more detail about the *Automatic Neighbor Relation* (ANR) SON use case [88], but in general all of these use cases are open for the adoption of different mechanisms to be defined outside the standard.

Focusing on self-healing, the requirements for general troubleshooting (not necessarily automatic) are presented in TSs [89][90]. The main standard specific references for self-healing are 3GPP TS 32.541 [91] and the *technical recommendation* (TR) 3GPP TR 32.823 [92]. Both documents contain general requirements for self-healing and they also sketch some steps to consider for a reduced set of use cases: *self-recovery of NE software* and *cell outage management* (COM) [93]: detection (COD), compensation (COC) and also recovery and return from compensation. Again, in any case, the standard does not define any specific mechanism to solve these cases and it does not analyze other key self-healing procedures (e.g. general diagnosis and detection of different problems).

### 3.1.2 Related projects

Different projects have focused on the development of new SON approaches and algorithms. The most important ones are listed in the subsections below, making a special remark to those results that influenced the present thesis.

#### Gandalf

The EUREKA CELTIC project [94] “Gandalf: Monitoring and self-tuning of RRM parameters in a multi-system network”, mentioned in Section 1.2, started in 2005 and it was focused on automatic diagnosis and tuning of the *radio resource management* (RRM) level of multi-system cellular networks [95]. The project integrated the efforts of France Telecom R&D, Ericsson, the University of Limerick, Telefónica R&D, Moltzen Intelligence Software and the Universidad de Málaga to achieve assisted and automatic optimization and diagnosis in multi-system cellular networks. A commercial troubleshooting tool was developed in the scope of this project, establishing also some of the foundations for further self-healing approaches [96][97][98][99].

Particularly, the work in [99] proposed a Bayesian method to apply KPIs values in the identification of network faults, defining a main approach for their automatic statistical analysis. The application of Naïve Bayesian Classifier is proposed in this article and it is also used as a baseline mechanism for some of the development of the present thesis.

#### FREEDOM

FP7 “FREEDOM: Femtocell-based network enhancement by interference management and coordination of information for seamless connectivity” project [100] focused on the physical characteristics of massive femtocells deployments, especially

on interference-aware cooperative techniques, seamless connectivity and simulation and evaluation of femtocells architecture.

## BeFEMTO

Ended in 2012 and participated by key telecommunication stakeholders such as Telefónica, Qualcomm and Docomo, the European FP7 project *Broadband Evolved FEMTO Networks* (BeFEMTO) was dedicated to the development of femtocells efficient solutions in LTE-A [101].

BeFEMTO sketched some key points for future small cell research. It identified the UE position as a SON enabler, developing different coverage estimation related algorithms, although without integrating it with end user localization services, neither analyzing the impact nor the possibilities of general context-awareness for self-organizing mechanisms [102].

It also presented an extension to the original 3GPP architecture by the addition of new core and local (customer domain) entities to be added to the standard model, respecting its general structure [103]. This architecture is presented in Figure 3.2. Its approach also stressed the used of local elements (e.g. introducing the *Local Femtocell GateWay*, LFGW) and local traffic breakout to minimize overloading of the operator's core and backhaul. Although, the concept of implementing new elements at local level is shared by the present thesis developments, BeFEMTO did not elaborate in the architectural impact of supporting context-aware SON.

## SEMAFOUR

Another FP7 project, “SEMAFOUR: Self-Management for Unified Heterogeneous Radio Access Networks”, ended in 2015, addressed the challenges introduced by heterogeneity in the cellular network management [104].

Here, different approaches for the inter-RAT and inter-layer coordination of the different SON functions were presented. For example, by making use of reinforcement learning for SON coordination [105].

Some of its works also made reference to the use of context, although in a completely different way as the one considered in the present thesis. Particularly, the paper [106] presented a cell classification method based on the *cell context attributes*, defined as those parameters associated to the nature of the cell itself: location (rural/urban), size, technology, etc. In this way, the UE context-aware SON analyzed in the present work is not considered by the project.

## 2. Overview of the BeFEMTO System Architecture

### 2.1 BeFEMTO Evolved Packet System Architecture

#### 2.1.1 Overview

The BeFEMTO Evolved Packet System (EPS) Architecture builds upon the 3GPP's Rel-10 EPS architecture and extends it in several respects. Figure 2 provides a graphical overview of the functional entities of this architecture as well as the interfaces between them.

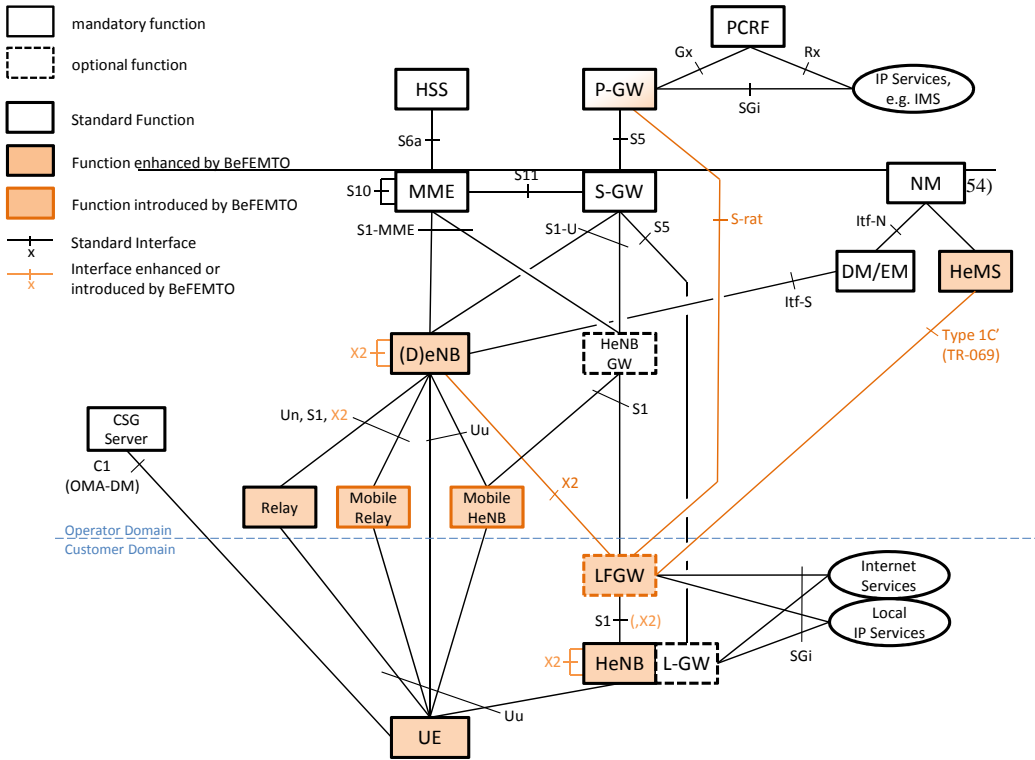

(b) BeFEMTO EPS Architecture [103].

Figure 3.2: BeFEMTO architecture.

For the sake of clarity, this overview only contains the most important entities of the Evolved Packet Core (EPC) and the Evolved UTRAN (E-UTRAN). Functional entities and interfaces that are enhanced or newly introduced by BeFEMTO are highlighted.

Finally, it is deemed necessary to indicate that most of the present thesis has been developed within the framework of the MONOLOC's project [42]. This project focuses on the development of an advanced platform for the management of mobile networks.

#### 2.1.2 Functional Entities

The BeFEMTO Evolved Packet System Architecture consists of the following main functional entities:

- Packet Data Network Gateway (P-GW) (enhanced):** The P-GW is the node that logically connects the User Equipment (UE) to the external packet data network; a UE may be connected to multiple P-GWs. The P-GW is responsible for anchoring the user plane mobility within the LTE/EPC network as well as for inter-RAT handovers. The P-GW supports the establishment of data bearers between the S-GW and itself and is responsible for IP address allocation for the UE, Differentiated Services Code Point (DSCP) marking of packets, traffic filtering using traffic flow templates and rate enforcement. **In the BeFEMTO EPS, the P-GW is enhanced for handling the S-rat interface for handling Local and Remote IP access consistently in terms of session and mobility management.**

- Serving Gateway (S-GW):** The S-GW handles the user data plane functionality and is involved in the routing and forwarding of data packets from the EPC to the P-GW via the S5 interface. The S-GW is connected to the eNB via an S1-U interface which provides user plane tunnelling and inter-eNB handovers (in coordination with the MME). The S-GW also performs mobility anchoring for intra-3GPP mobility; unlike with a P-GW, a UE is associated to only one S-GW at any point in time.

*Universidad Politécnica de Madrid (UPM)* and the *Universidad de Málaga*.

The project developed an innovative solution based on the combination of user context and position calculation, self-management of small-cells and location-based end-user applications. The aim was first to identify and develop positioning technologies especially for new mobile networks and use them to dynamically self-manage the network, being able to auto-configure, optimize and heal themselves. The project covered from the conceptual definition of the system to the deployment of on-the-field test case. In addition, *location-based services (LBS)* based on the proposed localization techniques were studied and deployed in live environments.

The target scenarios covered medium/large indoor areas (e.g. malls, corporate buildings, transport station...). In the trials, MONOLOC system was able to provide indoor navigation, support user applications (e.g. location-based advertising) and novel location-aware SON techniques making use of the assessment tools included in Appendix A.

## 3.2 Self-healing

This section focuses on self-healing, describing its main principles, functions and conditions as well as providing an overview of the key previous related works and the general scheme considered in this thesis.

### 3.2.1 Principles

To deepen in the characterization of self-healing functions, some key terms have to be introduced. Here, the nomenclature can sometimes slightly vary between different references. This thesis will follow the general definitions established by [107] and [29] for classical self-healing variables while proposing a self-healing model to consider the concepts introduced by this thesis.

In the analysis of network status and performance, *problems* are defined as situations of degraded service. For example, an increase in the percentage of dropped calls or access failures, reductions in the available throughput, the signal quality, etc. The problem *cause* or *fault* refers to the specific software or hardware malfunction that led to the service degradation. Typical causes include BS disconnection, interference, parameters misconfiguration, failures in the BS components, etc.

Even if their cause may be located at other points of the infrastructure, such as at the operator's core, the backhaul, etc., problems are commonly identified at cell level. In this way, if a cell has a problem, it is categorized as *problematic*.

Depending on the origin of the failure, a cell can be also categorized as *faulty*, if it provokes the cause/fault of the problem; or *victim* if the cell itself does not generate any fault but it is affected by other faulty cells. For example, a victim cell can be overloaded by the traffic coming from the outage of another close cell. Victim cells are usually adjacent neighboring cells to the faulty one, but not necessarily, as shown in Figure 3.3. For example, a cell can suffer interference coming from distant base stations transmitting at high power in the same frequency band.

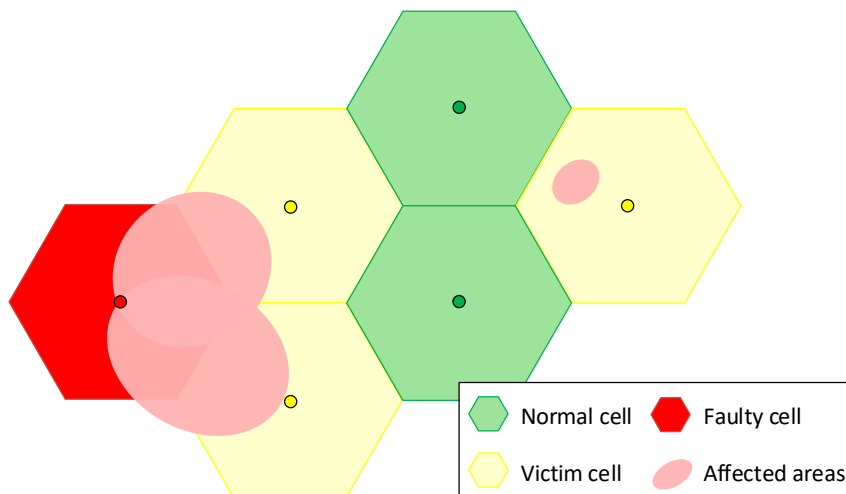

Figure 3.3: Faulty/victim cell example.

The problems are usually characterized by the nature of the generated degradation as presented in Table 3.1. This characterization is based on the different perspectives of the service provision (e.g. accessibility, throughput) affected by the degradation. Problems are typically defined qualitatively, as below certain degree, service provision is considered acceptable even with some level of degradation respect to the ideal. Some issues that follows a specific casuistry and affects multiple of these degradation categories are labeled with specific names, such as the *cell outage problem* [108], which refers to the complete failure of the service provision by a cell.

*Fault management*, also sometimes referred as *troubleshooting*, is the set of stages or *functions* associated with solving network issues. These functions are:

- *Detection* of network problems: identifying the presence of a degradation in the normal service provision of the system (e.g. an important increase of the number of dropped calls).

Table 3.1: Categorization of cellular network problems based on the affected characteristic of the service provision.

Category	Description
Accessibility	Incapability of UEs to access the network. It refers to connection attempts and correct establishment.
Retainability	Loss of service provision for UEs already being served.
Integrity	Quality of the service provisioned. Depending of the affected quality characteristic different subcategories can be defined: voice quality, throughput, signal power/quality.
Availability	The cell as available, it shall be considered available when the eNodeB can provide service in the cell.
Mobility	Related to the handover.
Network	Related to the network reachability of the elements of the system.

- *Prediction*: the same as detection, but if the problem is identified before the degradation occurs.
- *Diagnosis*, also called *root cause analysis*: consisting in the identification of the causes or faults behind a problem. For example, detecting that the increase in drops is due to a failure in the *radio frequency* RF components of a BS.
- *Compensation*: actions applied to minimize the impact of the problems before the fault itself is corrected. For example, by providing the service by other technologies or cells.
- *Recovery*: the activities associated with the correction/repair of the causes/faults behind the problem.

The detection of the network problems and the diagnosis of their causes are essential to the posterior selection and execution of the necessary *actions* to compensate for and/or recover the network from the fault. The makes detection and diagnosis the two main functions on which this thesis focuses.

These functions and their related activities are some of the most time and resources expensive tasks in cellular mobile networks operations. Faults in network elements, such as base stations, often require sending field engineers and/or technicians to the sites. The cellular network elements are extremely complex systems, involving multiple and redundant equipment, from power supplies to pure communication subsystems. The lack of a proper knowledge of the failure causes can lead to high delays in its correction and the need of multiple travels to the sites, resulting

in excessive costs and prolonged disruptions in the service provision. These issues can be attenuated by applying automatic systems to reduce the response time and associated expenses of these functions.

### 3.2.2 General scheme

Any automatic self-healing system must rely in the various sources of information and *variables* available in the network. From this perspective, self-healing follows a *hidden* (also known as *latent*) variables scheme [109]: the variables of interest for failure management, problems and network fault/causes are a priori hidden, meaning that they cannot be directly measured by any monitoring system. Instead, only related variables are observable, such as those associated with the service provision quality (e.g. percentage of dropped calls, throughput, etc.). The hidden variables should therefore be *inferred* from the observable ones. In this way, the detection mechanisms should be able to infer the presence of problems. Afterwards, the diagnosis methods should identify the causes/faults behind them.

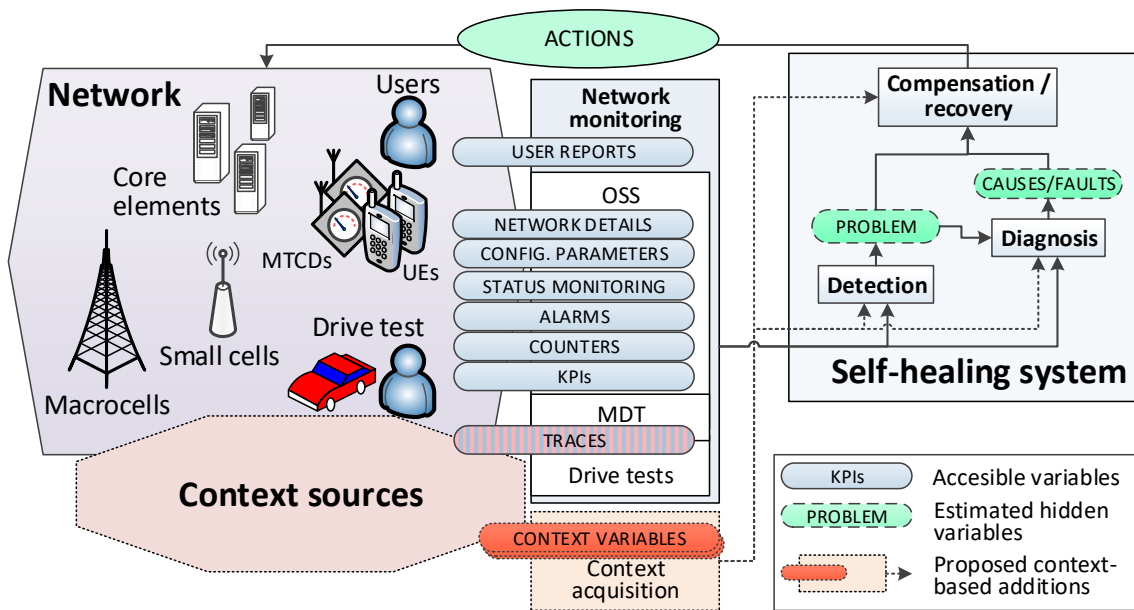

Figure 3.4: General network monitoring and self-healing scheme.

Based on this, Figure 3.4 defines the proposed self-healing scheme for the interactions between the different variables and the fault management functions. Variables are here represented by curved corner rectangles, where those that are estimated by the fault management functions are drawn with dashed lines. Although the scheme

focuses on self-healing, the same observable variables are also the available inputs for the other SON categories, especially for self-optimization. However, this relies in purely performance-related variables (such as the counters and KPIs) and typically ignore the fault-related ones (such as alarms).

The two main types of variables are identified. Firstly, *network variables*, implying those directly associated with the network status and characteristics. Secondly, *context variables*, those not directly related to the network but that can impact their performance or serves as input in its analysis.

The additions associated with the context (not considered in classical self-healing schemes) are drawn with dotted lines. Here, both external sources and the network itself might be providers of context information.

The next section is dedicated to the analysis of the network variables that are part of the common approaches for fault management, where context variables are further detailed in Section 3.3.

### 3.2.3 Network variables

Classic detection and diagnosis procedures shall be able to infer the network problems and causes/faults from the *observable* variables: *user reports*, *network details* and *configuration parameters*, *alarms*, *counters*, *KPIs*, *drive tests* and *traces*. The context-aware mechanisms later defined in this thesis will also combine these variables with context information.

Firstly, *user reports*, such as “complaints” and evaluations, were a common start point for troubleshooting. However, they are not typically considered as an integral component of automatic systems. This is in part because they are often not strictly formatted or quantifiable, so the failure management activities would have to rely in other network variables for the analysis. Also, the presence of users’ feedback about issues is an indication that the service has been already significantly impacted, and any automatic system should have identified and, if possible, corrected the issue before that point.

Hence, classic mechanisms have been based on the acquisition of network variables from the core elements and the BSs of the network, particularly:

- *Network details*: the data related to the nature of the deployed cellular system, which are supposed to remain fixed for prolonged periods of time (months). These include the characteristics of the network elements, especially the BSs and cells, such as their identification, technology, features, capabilities, topology, coordinates of deployment, etc. This information defines the general scope

for any OAM/SON activity.

- *Configuration parameters*: the values associated with the parametrization of the different network elements. This information typically includes both quantitative and qualitative data, such as the active features of the BSs, or its assigned resources (e.g. transmitted power, bandwidth). These are distinguishable from the network details in that they can be change in time by the operator (typically by remote commands) and they might vary in periods of days or weeks.
- *Status monitoring*: periodical or by demand checks and reports about the condition and connectivity of a network element, commonly base stations. For example, heartbeat signals used to test periodically if a system is active and connected with the rest of the network.
- *Alarms*: automatic event-triggered signals generated by network elements. These are typically characterized by representing a situation in a binary way, active or inactive. For example, a “NE disconnection” alarm would be triggered as active if the NE fails to answer one of a periodical set of handshake request. Alarms can also be triggered after a metric crosses a certain threshold.
- *Counters*: measurements periodically reported to the OAM system by network elements. The values of the counters represent the number of events of a certain type for a specific temporal period, classically of one day or one hour. For example, the number of user connections attempts.
- *Key performance indicators (KPIs)*: these are defined via formulas combining multiple counters with the intention of providing a more meaningful or efficient insight into the network performance. They commonly adopt the form of the ratio between the successful or failed number of events in relation to their total ones. For example, the *accessibility* KPI is defined as the ratio between the number of successful connection attempts and the total number of them [33].

The relations between these variables are often intricate. For example, parameters that might be fixed network details in some deployments, might be configurable and dynamic in others. Alarms can be generated if counters or KPIs crossed a certain threshold or if a status monitoring check is not successfully answered. KPIs can be defined as the combination of multiple counters or even by combining multiple KPIs.

These variables are typically available for the operator through the OSS, which stores the general network details and parameters, receives alarms and periodically gathers counters and calculates KPIs from the different network elements. Being a

centralized system overseeing the complete network, the periodicity of the information collection should be limited to daily or hourly measurements (as it is further analyzed in Section 4.1), because, if otherwise, the amount of data generated and the signaling costs would be not manageable.

Also, these variables are typically defined at NE level (e.g. BSs), without having visibility of the individual UEs, their conditions and protocol messaging. This might masquerade issues and make specific problems difficult to identify and characterize by the operator (e.g. coverage holes).

The need for a more detailed analysis of the network including geographical details is typically overcome by another source of information, the *drive tests*. These consist in measurements collected from specific operator's UEs. The measurements are organized in scheduled campaigns for specific routes or areas of interest to be traveled by vehicles or pedestrian staff equipped with one or several test UEs. These UEs are configured with specific monitoring software (e.g. [110][111]) allowing a detailed collection and reporting signal level/quality and protocol message analysis, as well as the execution of end-user quality tests. The use of *global navigation satellite systems* (GNSS) or manually introduced positions provides a geographical assessment of the quality and status of the cellular coverage.

Drive tests, however, imply sending personnel to the field and travel long distances. As drive tests are not regularly performed, these works are often outsourced to specialized companies. The measurements are just gathered for specific routes and very short periods, making its statistical relevance limited. Drive tests information is also gathered in the form of files in the test terminals that later need to be processed outside the OSS and with dedicated tools.

To avoid the limitations of traditional counters/KPIs and drive tests, NGMN and 3GPP identified different enablers for gathering detailed data directly from normal subscribers UEs and network elements [112]. These includes:

- *Subscriber and equipment traces*, which define mechanisms for monitoring specific NEs or UEs for a certain period of time. In this way, the common restrictions of hourly and daily counters/KPIs can be overcome when a more detailed analysis is required.
- *Minimization of Drive Tests* (MDT), incorporated to the 3GPP standard in recent years [113][114], enriches previous trace mechanisms by adding localization information to the UE reports. Here, UE positions are typically estimated by means of cellular techniques, e.g. timing advance, or GNSS. Given that the UE position included in the MDT traces is context, these are represented as both network and context variables in Figure 3.4.

The use of traces and MDT, although increase the detail of the data used for failure management, still present mayor challenges in terms of their processing, as the obtained information is commonly only analyzed by human experts and are not straightforwardly applicable to typical metric-analysis mechanisms (as it is going to be further detailed in Section 6.1). Also, their use in indoor scenarios is limited due to the lack of GNSS coverage and not applicability of classic cellular-based localization.

### 3.2.4 State of the art

Although a field of key importance, the application of automatic methods for troubleshooting in cellular networks has been until recent times relatively overlooked by the research community. This is especially true in comparison, for instance, with the substantial number of studies on self-optimization. This has been mainly due to the difficulty of analyzing failure cases, given the varied circumstances of their occurrence in real networks. Also, the personnel in charge of the detection, identification and correction of failures very often do not maintain rigorous, well-formatted and shared registry of failure cases, reducing even more the amount of data available [29].

The analysis of the state of the art will present the key previous references on the definition of general framework and architectures for self-healing as well as specific solutions applied for detection and diagnosis and the use of MDT data.

#### Frameworks and architectures

Early studies on automatic management of RAN failures focused on methods to achieve efficient visualization of the network operation. These tools ease the experts work, allowing them to perform fault detection and diagnosis based on human analysis of the cellular data. However, this was still a very difficult, time-consuming and inefficiently performed task, leading to further work about its automation.

Until now, studies on self-healing general systems and architectures had mainly focused their analysis in macrocell scenarios and using network solely network information. Barco et al. [29] and Hämäläinen et al. [30] proposed general frameworks for self-healing procedures in such environments, defining the principles for the use of KPIs for diagnosis purposes.

Szilagyi and Novaczki in [31] also introduced a framework for automatic detection and diagnosis, where specific algorithms where defined to manage network failures. However, once again, the applicability of context information or indoor small cell

scenarios were not addressed. The posterior study of Novaczki [32] introduced some improvements to the previous approach, indicating also in its conclusions the possibility of using context information for self-healing. However, this work does not include any specific development or definition in this regard.

Other works focus on specific particularities of automatic failure management: the work in [115] analyzes the applicability of big data concepts to self-healing process, elaborating in the impact of having vast amounts of information in the failure management of cellular networks.

Some research works have looked at small cell deployments and distributed systems in these scenarios, focusing however on topics outside troubleshooting [116][117][118]. Wang et al. [119] presented a distributed COD architecture mechanism for small cells, not being comprehensive for all self-healing and abstracting itself for the details of real deployments.

## Detection

In the field of fault detection, being the first step of self-healing, numerous studies have been conducted [120][121][122]. These works are based on the definition of a model for normal system operation. From this, detection is performed by identifying of the in the values of certain variables (e.g. KPIs) with respect to their normal ones. The identification can be simply based on fixed thresholds. However, such approaches are limited since different networks and environments might have different normal values, given the distinct cell loads, technologies, etc.

To avoid this, more refined mechanisms have been proposed. Cheung et al. [123] present two time-series analysis algorithms for detection of cell issues. The first of them calculates a baseline profile of the expected values of the variables based on previous periods (e.g. days) and detects the deviations based on the area difference between the curve of the expected profile and the current values of the metrics (counters or KPIs). However, such mechanism has limited applicability for varied time-changing variables, which make difficult the identification of fault deviations of the profiles in comparison with normal ones. The second algorithm performs correlation between a cell and its neighbors to detect if it deviates from them, which could be a relevant indicative of failure.

In the same line, the work in [124] proposes the use of the correlation between the metrics of different cells, applying the Pearson correlation coefficient to define the level of similarity between them. Those with low correlation are candidate to be considered degraded. However, in the same work it is described that only a reduced percentage of neighboring cells pairs are highly correlated, even if both are in normal

condition.

To avoid these limitations, Muñoz et al. [125] propose a mechanism based on the use of correlation between network metrics and model degraded patterns. These degraded patterns are achieved by combining series of the network metric considered as normal, with synthetic patterns emulating different degradation profiles (e.g. impulse, ramp). However, for each metric the generation of the degraded patterns must be performed for each defined synthetic pattern and for all their possible shifts or point of occurrence in respect to a normal metric segment. After that, all the possible degraded patterns need to be correlated with the metric. All these sums up to very high computational costs. Also, the method is impacted by the presence of long-term trends in the KPI, making the method unreliable in those situations.

Also, Khatib et al. in [126] define an algorithm dedicated to data reduction in self-healing environments, this means, for the acquisition and storage of just the period of the metrics which can be of interest for failure management. Such algorithms could be also used to detect network problems, where the system consists in applying a sliding window that checks the crossing of fixed thresholds. In the same way, as other described approaches, the applicability of a mechanism of these characteristics is much limited in the presence of daily or long-term variations in the metrics.

## Diagnosis

Once a problem has been detected, the diagnosis of the responsible cases/faults generally implies the use of more refined techniques than those used for detection.

Initial research on the field of the diagnosis of RAN issues focused on *alarm correlation*, which classic approaches include the references [127][128][129]. These alarms are directly generated by different network elements. The difficulty resides in that alarms typically corresponds to very low-level incidences: in the presence of a fault, a huge amount of alarms can be triggered, mixing those associated with the cause of the problem and those related only with its effects. Alarm correlation (also more generally known as event correlation) serves the purpose of minimizing the number of alarms into a more meaningful and manageable set. This process is usually performed in a sequential set of stages or processes, including: *textitcompression*, combining several occurrences in a single alarm; *suppression*, dedicated to avoiding minor alarms when those of higher importance are present; *Boolean substitution*, generating new alarms related to the original ones; *generalization*, etc.

Alarms analysis can be used as an initial step for the diagnosis. However, this rarely provides the detailed information that is required for the root cause analysis

of the specific fault. Firstly, even after alarm correlation, the number of alarms is commonly too big. Secondly, if alarms might clearly imply the presence of network issues, multiple causes can trigger the same alarms. Thirdly, many faults do not trigger any alarms. Particularly, those faults caused to the network elements by external systems (e.g. external interference). Therefore, the use of other variables, such as KPIs and counters is deemed essential, focusing the attention of the most recent works in root cause analysis.

In other fields apart from cellular communications, there are multiple references on automatic diagnosis, including medicine [130][131], printers [132], railway systems [133] or electronic circuits [134].

The diagnosis of cellular systems, however, has a set of characteristics that makes it different to other environments: the combination of continuous (e.g. counters and KPIs) and event-based variables, the dynamicity of the network (moving users, variable traffic), changes in the system configuration and elements, the impact of the context and the variability of the radio environment. These features make the self-healing techniques used in other domains not directly applicable to the scope of this thesis.

The main references for automatic diagnosis in cellular networks are based in the analysis of counters and /or KPIs of the base stations and other NEs by means of probabilistic algorithms and machine learning methods. The applied methods are typically heuristic, ranging from simple predefined linear functions based controllers, to more complex data-mining, artificial intelligence and machine learning algorithms.

The work in [135] proposed a self-diagnostic system based on Bayesian networks. To make the diagnosis, the system analyzed the main KPIs and alarms of the cells with detected problems. Also, the work in [136] focused on a Bayesian network based approach. In [137] an alternative system based on naive Bayes classifiers and the discrete modeling of KPIs, rather than a continuous one, was proposed. In [99] some of the methods defined in the above references were tested in a real UMTS network.

Genetic algorithms have been also recently proposed in [138]. This presented an evolutionary definition of the rules of the fuzzy logic controllers used for KPI-based diagnosis. Unsupervised methods have been also recently defined for detection and diagnosis. In [139] *self-organizing maps* (SOM) classify the sets of KPIs values in different clusters. Those clusters are consistent to different statuses of the network, with the intention of automatically grouping those moments affected by the presence of the same type of failure. In [140] performance functions identifying the state and failure case of the network are also defined in an unsupervised manner.

The system presented in [141] selects a set of candidate cell-level counters rele-

vant to UE transport layer performance metrics based on their correlation to them. The counters are then reduced clustered in different subsets. The selection of representative counters for each one allows to reduce the number of counters to be used as inputs for the diagnosis.

In [142] a hybrid ensemble of classification technique is proposed as a mean to combine several diagnosis models. The resulting system overcomes the limitations of its baseline individual classification techniques outperforming them.

## MDT

The works presented in the previous section limit their scope to the use of pure cellular information, looking only at their application to macrocell environments. As introduced in Chapter 3 and to be further assessed in Section 3.4, the additional use of context information would be necessary to fully cope with small cell indoor scenarios conditions.

As it will be shown in Section 3.3, although the use of context has been considered to support communication systems, there has not been directly applied for self-healing, when only preliminary SON analysis and limited use cases have been considered. For example, the works on MDT, can be considered in line with the idea of using direct UE information and location. However, MDT approaches mainly address offline performance of the network analysis for planning purposes (as reflected in Figure 3.1) and no previous work has presented a systematic approach for incorporating this information to online self-healing in indoor small cell environments. Also, the UE location is in most cases very imprecisely by cellular based methods or GNSS, which are not applicable in indoor scenarios.

Some previous works revolved around the use of this type of traces in macrocell scenarios. In this way, the early reference [143] proposed the use of diffusion maps (a data mining technique) for detection of the *sleeping cell* problem including the UE position as an additional input parameter. Not elaboration about the comprehensive application of other context variables is proposed. Posterior works of the same author also define different use cases and processing mechanisms for MDT data, such as N-gram analysis [144] and QoS verification [145][146]. Other references make use of *timing advance* (TA) measures between the terminal and the serving BS as an additional input for the identification of failure causes [147]. These works make limited use of context and focus only on macrocell scenarios.

## 3.3 Context

Context-awareness is an extremely powerful feature for intelligent systems. It consists in the utilization of context information, i.e. coming from the users' environment, behavior and the use of third party applications like social media, to enhance the provision of services and applications [39][148].

This concept appeared initially in the field of ubiquitous computing, where devices and sensors are distributed extensively in the environment. In this way, a great amount of information about the users' behavior and their surroundings is accessible and it can be applied to adapt and optimize services and systems, achieving improved efficiency.

### 3.3.1 Related work

Different works have defined use cases and specific applications where context-awareness can highly improve telecommunication systems. In this line, reference [149] defined the use of a semantic reasoner and clustering map in the field of general telecommunication service adaptation. Later works provide specific use cases in this line, such as satellite communications [150] or the adaptation of communication services to the specific needs of users [151]. These references focused on the processing of the context variables and service adaptation to UEs requirements, without entering into the definition of mechanisms to apply the information to OAM / SON activities, for self-healing or taking into account the peculiarities of small indoor cells.

Additionally, 3GPP technical recommendation [152] (first version on March 2016) provides a high-level study on context aware service delivery, which focused in content caching and *performance enhancing proxies* (PEPs) based on UEs E2E demand, particularly for video services. This again did not address the objectives of this thesis either in the field of SON, self-healing or in the kind of context variables to consider.

Reference [57] reflected on the possibilities introduced by the knowledge of UE location applied to the physical, MAC, network and higher layers mechanisms of the cellular communication system. The presented advantages are wide, and different challenges are identified, particularly from the perspective of channel modeling and signaling. However, general SON functions are not addressed and only some specific SON use cases (e.g. mobility load balancing) are mentioned.

The work in [153] outlined a framework for cell configuration and deployment based on the use of *network topology*, *state* and *environment* and other possible

operator's inputs, without entering in detail about these other variables or their use in different mechanisms.

Reference [154] developed on the specifics of a context-aware handover decision between LTE and Wi-Fi taking into consideration UE-state context variables like *application*, *battery*, *terminal type* and *velocity* (among others), as well as service-oriented ones (e.g. jitter, delay, data rate). The algorithm was proposed to be implemented in a pre-existent 3GPP element, the *Access Network Discovery and Selection Function* (ANDSF) entity.

The work in [155] presented a framework to support the use of context information for public safety networks in LTE. Particularly, it sketched the elements for context-aware RRM in a very high-level perspective. It also summarized existing communication protocols that make use of context info (e.g. *location*, *apps*, *user preferences*, *security*) to improve the quality of experience. Other works also developed on RRM applications of the UE context, as the one presented in [156] with makes uses of UE velocity and other parameters for pilot-utilization, channel identification and *adaptive modulation and coding* (ACM).

Reference [157] develops an adaptable handover algorithm for vehicular HetNets environments. This makes use of the conditions of the *environment* crossed by the UE: foliage density and wind speed.

### 3.3.2 Indoor localization techniques

As seen from the previous works, the UE location is one of the most important context variables. The use of localization in cellular systems commonly relied on GNSS or cellular-based positioning techniques not applicable indoors [158]. However, alternative indoor mechanisms will have a crucial role in the new cellular environments, not only as a source of support for the cellular management, but also to provide end-user services. One of the main key challenges for the operators is to find *killer apps*, this means applications so innovative and desirable that lead customer to acquire cellular services, data plans and advance terminals. In this field, LBS can support key new applications in advertising, domotics, health care, emergency response, logistics, and so on.

The most suitable scenarios for LBS are medium/large indoor areas (e.g., corporate buildings, malls, hospitals, airports) given the large concentration of users in these environments. Therefore, several mechanisms have been developed to provide localization in scenarios where the UEs are completely positioned [159][160]. In this way, UE localization systems are expected to be increasingly available in indoor scenarios, which can be based on different technologies under study or already com-

mercialized [158][161][162][163]. These are often based on the analysis of the received signal characteristics (e.g. time of arrival, received power, etc.) from different systems such as *radio-frequency identification* (RFID) [164], Near-field communication (NFC) [165], WiFi [166], cellular [159] and *ultra-wideband* (UWB) [167].

Therefore, precise information about the position of the UEs is becoming a common asset for smartphone applications and, consequently, industry is starting to take advantage of it to offer a wide diversity of location-based services. It is envisaged that these technologies would become deeply extended due to the increased interest and effort applied by key-players such as Google and Apple [158][168].

Also, 5G scenarios, with its ultra-dense deployments, high frequencies and massive use of MIMO are expected to provide a very precise and ubiquitous cellular-based indoor localization directly accessible by the operators, making straightforward its application to SON [169][170].

### 3.3.3 Wrap-up

Although different works demonstrated specific applications and use cases where context-awareness and especially location can highly improve telecommunications systems, previous to this thesis and its associated publications, integration with SON systems was never fully addressed. In this field, UEs location is considered a key context variable for SON, where it is expected to be fully available for both indoor and outdoor scenarios in the near future.

## 3.4 Small cell challenges and context-awareness

As presented in the previous sections, for SON functions, the statistical analysis of network variables (e.g. KPIs) is the key mechanism for decision. In self-healing, the comparison of the statistical profiles of different cases (i.e. under normal condition or different fault causes) is crucial to properly detect and diagnose failures. Here, a profile refers to a variable distribution calculated based on the measurements (from different users, cells or other elements) during a certain period of time.

As long as there are significant differences in the statistical profiles of two cases, the fault causes can be distinguished by means of analysis the profiles themselves or derived statistics (e.g. mean) [29][30].

In this respect, indoor small cell deployments contain wide differences with macrocell ones, as shown in Figure 3.5 and summarized in Table 3.2. Between them, the differences that imply major challenges in the statistical analysis include:

- Reduced monitoring: Due to the limited hardware and computational capacity of small cell stations, their monitoring has been designed to minimize the number of reported alarms and KPIs, reducing the available information for troubleshooting purposes.
- Irregular and overlapped cell areas, which makes detection and diagnosis of cell failures extremely difficult, as the fault may not cause clear coverage holes or complete failure of service provision.
- Performance variations: In classical self-healing solutions, a large set of measurements is needed to have a statically trustable data set to lead the algorithms to consistent results. However, in small cells, given the reduced size of the cell area, users can move from its center to its borders very quickly (seconds). In addition, a certain base station could easily have few or no terminals connected to it, generating situations where there may not be enough valuable information of a failure for very long periods.

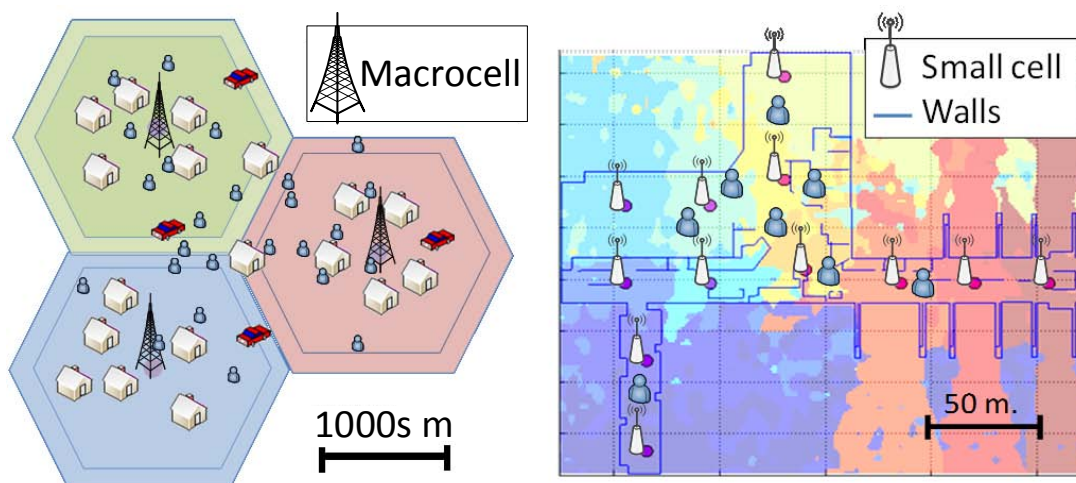

Figure 3.5: Macrocell outdoor and small-cell indoor scenarios.

Given the described characteristic of indoor scenarios, often a very long period (with large enough number of measurements) is needed to generate a reliable profile for the diagnosis. In addition, the statistical distribution of fault cases normally does not deviate enough from the normal behavior or between different causes to find significant statistical difference.

Conversely, if context variables are considered, reports from the UEs can be analyzed depending on the context where they were measured, e.g. in the edge

Table 3.2: Characteristics of macrocell outdoor and small cell indoor deployments.

Characteristic	Macrocell outdoor	Small cell indoor
Robustness	Reliable elements	Vulnerable elements
Infrastructure	Dedicated	Shared
Cell size	Kilometers	10s of meters
Deployment	Planned	Typically unplanned
Coverage areas	Relatively defined	Irregular, overlapped
Monitoring	Large number of KPIs and alarms	Reduced: simplified KPIs and alarms
Performance variations	“Slow” (hours), large number of users	“Fast(min/secs) ”, very variable user distributions

between cells, in an area close to the serving cell center, etc. For instance, samples from a specific cell (e.g. received power) may be not existent. This lack of samples may just be caused by a specific distribution of users (e.g. there is no UE in the cell coverage) or due to a real failure, where both cases cannot be distinguished without positioning information. Also, variations in the user distributions can lead to apparent performance degradations even if the cell works properly (e.g. if the users are mainly located in the edge of the cell). Conversely, context information will help to distinguish faulty situations from those caused by the user distribution.

Figure 3.6 presents an example of the impact of using context information for two scenarios, one simulated (left-side) and one in a real testbed (right-side). The detailed characteristics of both the simulator and the testbed are described in Appendix A. In these, two different failures in one of their small cells is analyzed:

Looking at their main details for this assessment:

- In the simulator, an airport scenario with 12 LTE picocells is modeled with variable user concentrations and mobility. The small cell labeled as “8” is the faulty element for the failure cases.
- For the real testbed, multiple static UEs are distributed in a large office area with four UMTS femtocells. The one labeled as “femto\_x1” is the faulty one in this case.

These scenarios were both designed modeling realistic small cell deployments and they are also consistent with the type of scenarios expected in 5G indoor hotspot scenarios [68]: single layer indoor floor (open office style), *inter-site distance* (ISD)

in the range of dozens of meters. In these, it is expected an important degree of overlapping as the small cells disposition follows capacity-driven criteria. Also, their overlapping with macro-coverage is expected to be a constant in most environments [171][74][172].

In both scenarios, the measurements related to the power of the serving cell received signals are obtained from the UEs: for the simulated LTE scenario, the *Reference signal received power* (RSRP) [173] and the *common pilot channel* (CPICH) *received signal code power* (RSCP) [174] in the UMTS one. In both cases measurements are obtained once per second. For the simulated airport scenario, the UEs move around the area, while in the real office testbed the UE positions are fixed.

The two graphs at the top, Figure 3.6-a, present the statistical profile, calculated as the *empirical probability density function* (epdf) [175] obtained from the gathered samples.

The profiles are based on the measurement gathered from the UEs in the complete scenarios. Here, indicator distributions are presented for three different testbed conditions: normal case (blue, circle mark); cell outage (green, upward-pointing triangle mark); incorrect configuration of a cell transmitted power, which leads it to emitting 15 dB above their normal value (red, left-pointing triangle mark).

From the graphs, it can be observed the difficulty of differentiating between the represented cases, as the distributions are very similar. For example, in the outage case, the overlapping between cells make the RSCP and RSRP values to stay at appropriate for the terminals once served by the faulty cell level, and now served by its adjacent ones. Also, in order to impact the general profiles or the ones from their new serving cells (it is going to be deeply analyzed in further chapters), the number of samples in the area affected by the failure should have been large in comparison with the rest of served UEs. Consequently, the distributions remain nearly unchanged after the failure.

However, if, as context information, the position of the terminals is used, as represented in Figure 3.6-b, further processing of the indicators can be performed. For instance, if just the terminals located in the cell center are considered, the profiles calculated for such terminals measurements present a much clearer distinction between them (see Figure 3.6-c, bottom graphs). The statistical profile change in this case can be clearly observed, making easier to distinguish the different causes/faults by the analysis of the profiles or simply by observing their mean value, showing the capabilities of context-awareness to improve self-healing mechanisms.

Other context variables will support further refinements of the analysis, e.g. the date and time, UE model, orientation, data use and/or running applications. The UE model and orientation can support more precise comparison of the received

power values with previous ones. Other data, e.g. the UE densities and applications, can help to identify if certain indicators (e.g. signal quality) are normal given the level of network occupancy or can be associated to a faulty condition, as well as to predict degradations by estimating expected user distributions and service demands. A detailed analysis of the context variables considered in previous works is provided in the next section.

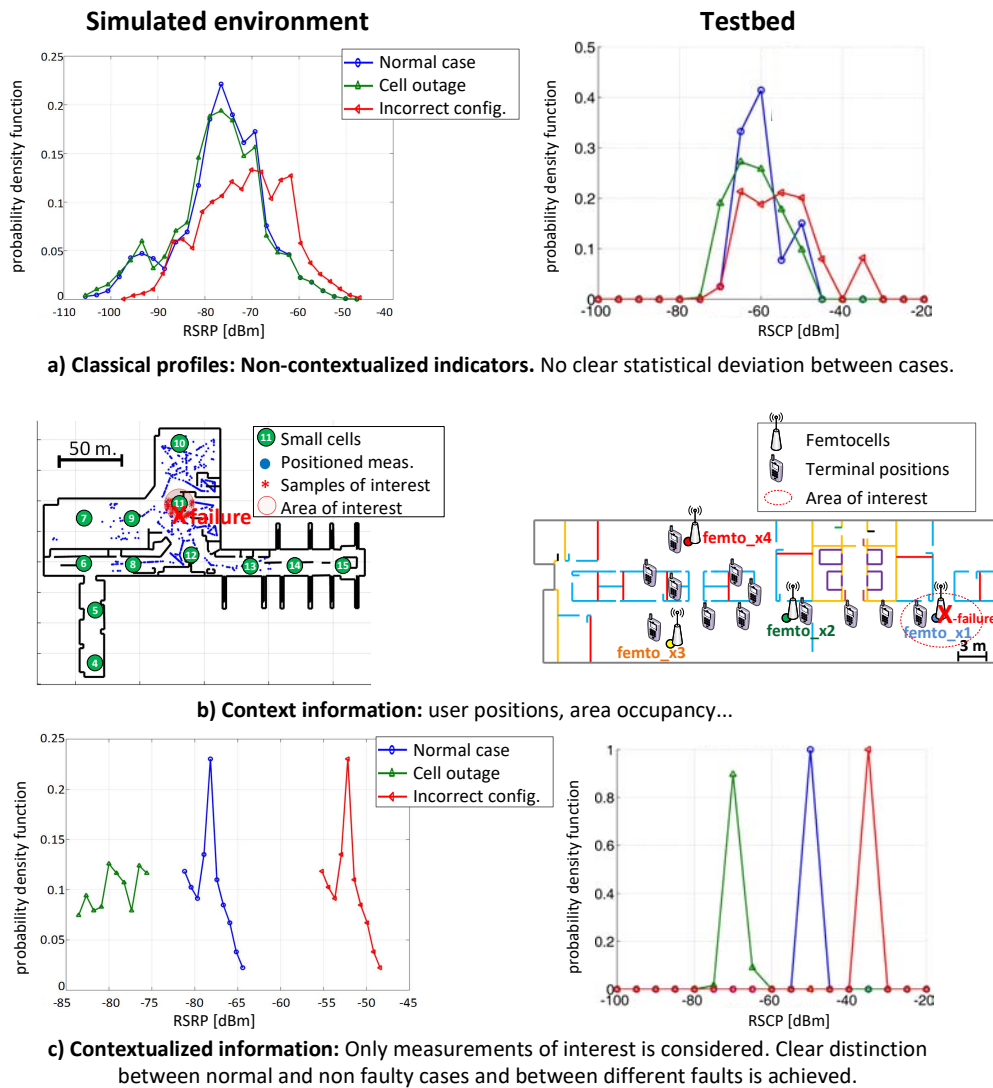

Figure 3.6: Example of statistical differences between cases based on context-information.

### 3.5 SON-aware context

Although it is not the main scope of the present work, during this thesis the applicability of cellular and SON information for the generation of context and its use by other applications or services was also analyzed. Notice that this is the opposite approach to the main proposed focus: to consider SON as input for other applications, such as LBS, instead of using context, e.g. location, as input for SON.

The cellular network can be by itself a source of context information, as it will be detailed in Section 4.2. In this way, the cellular network can directly have access to information about data use, position, speed and many other variables. Also, the cellular entities can help to support the acquisition of context variables by external systems. This is especially important in the case of positioning systems based on the analysis of the cellular radio signals, where the use of small cell deployments would highly increase its precision. If that is the case, the cellular network can be planned to optimize the performance of the coexistent indoor localization system [159].

Also, when SON functions are active in the network, action changes performed in the configuration of the BSs (e.g. transmitted power variation for self-optimization or compensation of the network) can greatly impact the performance of the positioning system. At the same time, the detection of failures and degradations in the BSs can hugely serve the positioning system to correct its calculations and keep a high precision even in the presence of problems in the network. This requires also the establishment of coordination between the SON mechanisms

Especially cell-based localization will benefit from the knowledge provided by the SON functions. Since in that case the positioning techniques are based on the analysis of the radio signals from the cells, the modification of network parameters (e.g. cell transmitted power) by SON should be considered for users' position calculation. In addition, self-healing techniques, whose aim is to detect and diagnose problems on the small cells, will alert localization functions on the need of modifying the calculations when a cell is in outage. Moreover, information on the status of the network can provide additional information to the localization algorithms.

### 3.6 Conclusions of the chapter

This chapter has analyzed the main principles and the state of the art of SON and self-healing. From this, the integration of context and SON has been demonstrated to be of great interest in cellular networks, although previous works have



not thoroughly developed on the requirements, capabilities and mechanisms that context-awareness brings to SON. In this way, the following chapters will address these shortcomings of previous bibliography.

# Chapter 4

## Management architecture for context-aware SON

### Content

---

4.1	Motivation . . . . .	59
4.2	Problem description . . . . .	60
4.2.1	Sources of context data . . . . .	61
4.2.2	Challenges for the architecture . . . . .	62
4.3	Proposed SON architecture . . . . .	65
4.3.1	Objectives . . . . .	65
4.3.2	Functional model . . . . .	65
4.3.3	SON entity options . . . . .	70
4.3.4	Implementation model for femtocell LTE/LTE-A deployments . . . . .	70
4.3.5	System responsibility . . . . .	72
4.4	Proof of concept: load balancing . . . . .	73
4.4.1	Baseline algorithm . . . . .	74
4.4.2	Evaluation . . . . .	78
4.5	Context traffic assessment . . . . .	81
4.5.1	UE context report . . . . .	82
4.5.2	Comparison with cellular networks capacity . . . . .	83
4.6	Conclusions of the chapter . . . . .	85

---



This chapter proposes a novel architecture for next-generation cellular networks at indoor scenarios. The defined system will be used as the base for systems providing context-aware SON techniques in medium/large indoor areas (e.g. malls or corporate buildings). The functional and physical characteristics of this architecture and their technical implications are also analyzed. Different innovations to the generic mobile architecture are proposed as well as their specific implementation for LTE/LTE-A. The interoperability with standard management systems and context services, congestion avoidance and data offloading are the key drivers of the design. Accordingly, the specifics and challenges of the integration of context information in the management layer of cellular communications are defined and the signaling impact of such an approach is assessed.

Section 4.1 summarily introduces the challenges of the integration of context and SON. Section 4.2 describes the main sources of context data in context-aware cellular networks and their specific particularities for its use as input of OAM/SON system. Based on these, Section 4.3 presents the objectives and defines the proposed OAM architecture. In addition, an implementation model for the specific case of the LTE/LTE-A standard is presented. In Section 4.4, an example case algorithm is used for the architecture evaluation. Also, Section 4.5 assesses the context traffic costs of the proposed system for different configurations. Finally, Section 4.6 presents the conclusions of the chapter.

The work presented in this chapter has been partially published in the following work of the author<sup>1</sup>:

- S. Fortes, A. Aguilar-García, R. Barco, F. Barba, J. Fernández-Luque, and A. Fernández-Durán, “Management architecture for location-aware self-organizing LTE/LTE-A small cell networks,” *Communications Magazine, IEEE*, vol. 53, pp. 294–302, January 2015.
- A. Aguilar-Garcia, R. Barco, S. Fortes, and P. Muñoz, “Load balancing mechanisms for indoor temporarily overloaded heterogeneous femtocell networks,” *EURASIP Journal on Wireless Communications and Networking*, vol. 2015, p. 29, feb 2015.
- S. Fortes, A. Aguilar-García, R. Barco, F. Barba, J. Fernández-Luque, and A. Fernández-Durán, “Diseño Integrado de Redes Auto-Organizadas LTE/LTE-A y Posicionamiento en Interiores,” in *XXVIII Simposium Nacional de la Unión Científica Internacional de Radio - URSI 2013*, Sep 2013.

---

<sup>1</sup>Also, the contributions of this chapter were developed in close collaboration with Alejandro Aguilar-García, also part of the MOBILENET group.

## 4.1 Motivation

Context-aware techniques can highly benefit for an integrated architecture able to provide the same context information to different SON mechanisms, avoiding possible collisions due to the use of heterogeneous data. This would also allow the use of cellular information to support the context services.

However, one of the main challenges for a comprehensive usage of UE context in SON mechanisms consists in the definition of an architecture able to provide the context information to the OAM plane of the network operator, where context and SON have very different characteristics and restrictions, as presented in Table 4.1. On the one hand, context sources implementations normally follow a UE focused approach, where each terminal communicates with a centralized manager/server able to perform the (sometimes computationally expensive) algorithms and able to store the (memory-heavy) databases containing the UE data (e.g. position, social networks, etc.). Also, as the users are continuously changing their context, the time scope of the context related procedures is typically very short, varying in the order of seconds/milliseconds.

On the other hand, traditional OAM functions have time spans of hours or days (e.g. the change of small cell parameters is typically performed once a day). SON functionalities, if present, are deployed as part of the OAM architecture. A reduction in SON time spans to the order of minutes and even seconds is foreseen in the close future [107]. However, in comparison, context is still much more dynamic in nature.

Additionally, as it is going to be further developed in Section 4.3.5, while the OAM/SON system is part of the network operator, context sources can have different responsible entities: third parties, end-users, etc., with various objectives, systems and intentions.

Table 4.1: General characteristics of context sources and SON mechanisms.

Characteristic	Context servers	OAM/SON
Main elements	UEs, context services	OAM architecture, BSs
Time span	secs/msecs	<i>Classic:</i> daily, weekly; <i>Foreseen:</i> secs, mins
Spatial scope	Local scenario/spot	Operator's network, subnetwork
Responsible	Third parties, end-users, operator	Operator

To allow the practical development of context-based SON techniques under the particular conditions of indoor scenarios (coverage overlapping, variable user distributions, cell load, etc.), the support of a complete OAM architecture able to

integrate the available context services with SON mechanisms is deemed indispensable.

This is a novel approach where little work has been developed in the literature. From the system and architectural perspectives, there have been only a few works addressing the requirements to consider the integration of context information into the management plane of cellular networks.

As analyzed in Section 3.1.2 BeFEMTO project presented an architecture that includes the use of local location [101] as SON enabler but it does not integrate it with end user context services, neither analyzes the impact nor the possibilities of general context-aware self-organizing mechanisms.

The work in [155] presents a framework to support the use of context information for public safety networks in LTE. Particularly, it sketches the elements for context-aware RRM in a very high level. It also summarizes existing communication protocols that make use of context info (e.g. location, apps, user preferences, security) to improve the quality of experience. However, it just defines a high-level particularization of the possible entities of a context-aware system.

As commented in Section 3.3 few works have look to the general architectures or frameworks for the integration of context in the cellular network and for SON mechanisms. Reference [149] elaborated on the use of context information for telecommunication, specifically for service-adaptation, defining a framework for its use in GSM and UMTS. A context message scheme is also proposed, together with a context map approach based on clustering and semantic reasoning. However, previous references did not analyze either the particularities of self-healing in small cell deployments or the potentialities of using context-awareness for self-organizing networks or self-healing purposes.

Summarizing, although context-awareness has been demonstrated to be of great interest in future networks, no previous work has properly assessed the requirements for its integration in cellular networks. Therefore, a specific small cell architecture able to integrate external location services is deemed necessary for supporting location-based SON in indoor scenarios, being the objective addressed in this work.

## 4.2 Problem description

To adopt context in the communication network, it is deemed necessary to consider, on the one hand, the sources of context information to be considered; on the other hand, the challenges of integrating those sources into a common architecture.

### 4.2.1 Sources of context data

In the cellular environment, the available sources of context information are varied and the context variables that can be obtained from them are very diverse (as shown in Section 3.3). The elements that can provide context information, or *context sources*, include both non-communication elements (e.g. user services) and entities of the cellular network itself (e.g. BSs, UEs, etc.) can be key providers of non-telecommunication information. Also, these cellular network entities are the ones where the SON mechanisms can be implemented. In this way, the impact of the overhead introduced by context management (acquisition, dissemination, etc.) would highly depend on where these would be implemented.

In this way, the main context sources are:

- **Network terminals (H2H UEs and MTCs)** are the main sources of context information, gathered directly through their sensors, their configuration/execution data or obtained from external context sources by user-level services and apps (e.g. location). They can also provide detailed telecom-related information in terms of individual radio measurement, *Quality of Experience* (QoE), etc.
- **External context sources** outside the cellular network. With the extension of cloud services, social networks and remote applications, a huge amount of information about the terminals and their environment is calculated/stored in external servers. Additionally, other environmental information of potential importance for the network performance can be produced/found in these external systems. For example, weather conditions or end-to-end measurements.
- **Base stations** also gather much context information about the UEs. Specifically, they can serve as sources of cellular based localization, velocity and UE activity.
- **Operator's core elements** serve as concentrators of context information. User profiling, mobility based variables, traffic performance and end-to-end analysis can be also obtained from them.

These sources and their main context variables, together with their telecom element-specific info, are summarized in Figure 4.1. Additionally, the communication links between the different elements are represented.

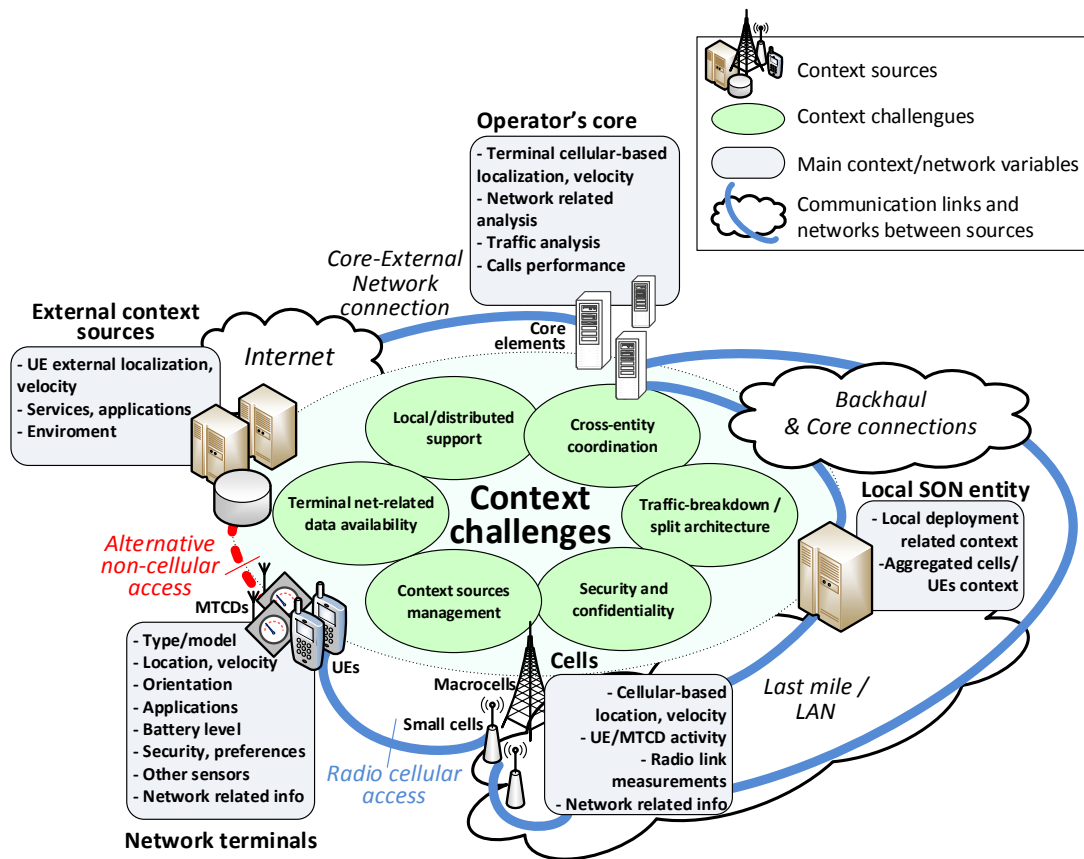

Figure 4.1: Sources, challenges and main variables for a cellular-context integration scheme.

## 4.2.2 Challenges for the architecture

The use of context information in SON mechanisms implies a set of important challenges for the current model of the cellular network. The key features to be considered are gathered in Figure 4.1, and further detailed below:

- Local/distributed support:** An increment in the amount of SON capabilities to be implemented by the cell themselves or by local entities (those “close” to the cells, e.g. in the same *local area network* - LAN / last mile) is deemed necessary, on the one hand, to reduce the amount of signaling with the elements of the core network. It also makes the approaches more robust against failures in the core and in their communication links. On the other hand, it facilitates the conceptual development of mechanisms that shall cover complex

networks and systems. This distributed nature also must be supported by the context-aware SON architecture, especially in the exchange of context between cells.

- **Cross-entity coordination:** Even if the functions are implemented at local level, monitoring, accountability and control of the SON actions should be possible from higher layers of the cellular management plane. This makes cross-entity coordination indispensable between the elements of the local deployment and the higher elements of the management hierarchy.
- **Traffic-breakdown / split architecture:** Current architectures (e.g. LTE) were defined in such a way that all Internet traffic is routed through the core, mainly for accountability and billing purposes. Further refinements, like *Local IP Access (LIPA)* and *Selected IP Traffic Offload (SIPTO)*, allow base stations to route some of the user-plane traffic directly to other elements in the LAN or to Internet. These capabilities can be crucial to reduce the impact of context acquisition and propagation in the context-aware network. Additional breakdown techniques can be possible for the context traffic, as it would be part of the management plane of the operator.

Moreover, new proposals in the direction of *split architectures* of the control, management and user planes, expected to be common in 5G approaches, could be especially applicable to avoid overloading of the cellular network with the reported context signaling. Context flows would typically not have so stringent requirements in terms of throughput, delay and reliability and therefore their traffic could be steered through different mediums or technologies (e.g. WiFi, overlaid macrocell, etc.).

- **Context sources management:** As presented in Figure 4.1, the high-layer information obtained from terminals and external entities (e.g. localization services, social networks, etc.) are key context data. However, such information is not part of the cellular network itself. Its use can therefore make operator's systems dependent on non-controllable external entities. To overcome this issue, any context-aware SON approach should consider some key features in the management of context sources [40]:
  - *Discovery and registering:* Context sources, especially if they are external to the cellular system (e.g. social networks), need to be formally discovered and registered to ease and accelerate their use. Equally, standardized procedures for the agreement and billing of the external entities should be as automatic and clearly-defined as possible.
  - *Trustworthiness and accountability:* Authentication of the context sources and guarantees of the quality of the context provided shall be established.



- *Data and configuration compliance:* Changes in format or other source details on the context sources can lead to failures in its acquisition. To avoid that, proper coordination, version control and update on those changes shall be implemented.
  - *Context aggregation and fusion:* Various sources often provide the same or complimentary variables. Therefore, it is necessary to define the policies and procedures associated with the fusion of data from different origins, taking also into account their classification based on trustworthiness, accuracy, etc.
- **Terminal network-related data availability:** The analysis of the existent SON context-aware mechanisms and real implementations have identified the need of improving the acquisition of terminal-level network-related data. Particularly, the access to network related parameters for serving and neighboring cells is necessary for both the management plane and at the operative system level of UEs. This would be key to support both, over-the-top context sources (e.g. UE cellular-based localization) as well as to increase the possibilities of inter-layer coordination of the SON mechanisms and context sources.
  - **Security:** An important challenge of the proposed approach is to guarantee the security of the context data. There are multiple end-to-end protocols that could support the three main aspects of secure communications: *confidentiality*, *integrity* and *availability* (e.g. IPsec), always at the cost of increasing complexity and signaling. Also, standardized link-level, backhaul and terminal to core elements security are commonly defined for cellular-networks control data, making possible to straightforward apply the same level of security to context-data exchanges.

Additionally, many SON algorithms can rely on anonymous data. This means that the information does not require to be identified as coming from a precise terminal, e.g. the contextualized indicators that will be presented in Chapter 6 use completely anonymous data. This, although clearly does not cover all possible threats, helps to reduce the impact of security breaches, including not only the radio access and core transmissions, but also in the databases where the context information might be stored.

## 4.3 Proposed SON architecture

### 4.3.1 Objectives

The following requisites have been defined to support the implementation of the proposed architecture in real networks:

- **3GPP standards conformity:** the architecture should follow as much as possible the 3GPP standards or it should be implementable as an extension or addition to those standards, making use of its already defined interfaces.
- **Integration with previous OAM mechanisms:** the developed systems and mechanisms shall be able to integrate and coordinates with pre-existent OAM functionalities.
- **Communications versatility:** allowing freedom of implementation and interaction between the different elements.
- **Reduced signaling:** so the transference of the information between the different element does not congestion the operator's core or the backhaul.
- **Management speed:** for a quick monitoring and rapid execution of actions over the network.
- **Commercial applicability:** taking the possibilities of the architecture to be integrated as part of real products and support commercial services, increasing its marketability.

### 4.3.2 Functional model

The proposed OAM architecture is defined by several interrelated entities. Here, different approaches can be adopted to establish its functional scheme: *centralized*, where a unique entity is in charge of managing the rest of the elements; *distributed* (peer-to-peer); and *hybrid*, with a combination of the characteristics of the previous options, e.g. some mechanisms are completely local while others require coordination among distributed entities. The proposed solution follows a hybrid scheme. Even if this approach implies the need of a centralized OAM element, it is chosen as it allows easy reuse of classical centralized OAM architecture, while the implementation of distributed mechanisms is also supported.

As presented in Figure 4.2, the core of the standard 3GPP OAM architecture [52] is maintained, adding new capabilities, functions, entities and interfaces to it. The

placement of classical SON functions in the standard OAM entities (NM, DM, EM and NE as presented in Section 2.3) follows a similar scheme to the one presented in [107]. Hence, the functions involving a specific subnetwork can be implemented at the DM layer. For functions involving more than one subnetwork (e.g. the coordination with macro cell coverage) the function will reside on higher layers of the OAM hierarchy. Conversely, distributed SON functions would be placed at EM layer and NE (e.g. small cells). In these classic entities, the level occupied by the tool/mechanism at the OAM architecture chain is directly associated to the time span for monitoring and configuration and the level of abstraction over the network elements [107] (see Table 4.2).

Table 4.2: 3GPP standard OAM layers characteristics.

Entity	Task	Parameter abstraction	Time span
NM	Planning	Vendor independent	weeks/month
EM/DM	Network Operation	Vendor independent/specific	hours/days
NE	Element Configuration	All parameters	secs/mins

However, even for the lowest layer standard centralized entity (the DM), time spans (in the range of hours) are still large. Also, DM usually operates non-overlapped subnetworks covering wide areas. Hence, a novel additional OAM functional block, the *OAM Context-Aware System* (OCAS), is proposed to support innovative location-based SON mechanisms. This new proposed centralized entity is to be implemented at the lowest levels of the OAM hierarchy, being in charge of managing the set of small cells of one specific indoor area.

In this way, the proposed architecture is shown in Figure 4.2. Here, the standard OAM architecture is represented (blue left square) containing the described standard NM, EM/DM and NE elements. These are connected by newly defined interfaces (see Section 4.3.2) to the OCAS, which implements the following roles:

- It registers available *context services* (CSs) and obtains location information from them.
- It implements location-aware SON functions.
- It acts as coordinator for the interaction between the OAM elements of the mobile network, context-aware SON algorithms and CSs. It also propagates the results of the context-aware system to the rest of the OAM systems.
- It propagates the results of the context-aware SON algorithms to the OAM standard elements for their authorization to apply the decided commands in

the network. Then these commands may be applied through standard OAM elements or directly to the devices by the OCAS itself depending on operator policies.

Also, additional *monitoring and reporting functions* (M/R) can be incorporated into the UEs. In this way, they can directly report to the OCAS information about the network status or their location. This M/R capability can be part of the location-based applications present in the terminals (e.g. navigation app) or being implemented by means of directly invoking functionalities in the terminal *application program interface* (API).

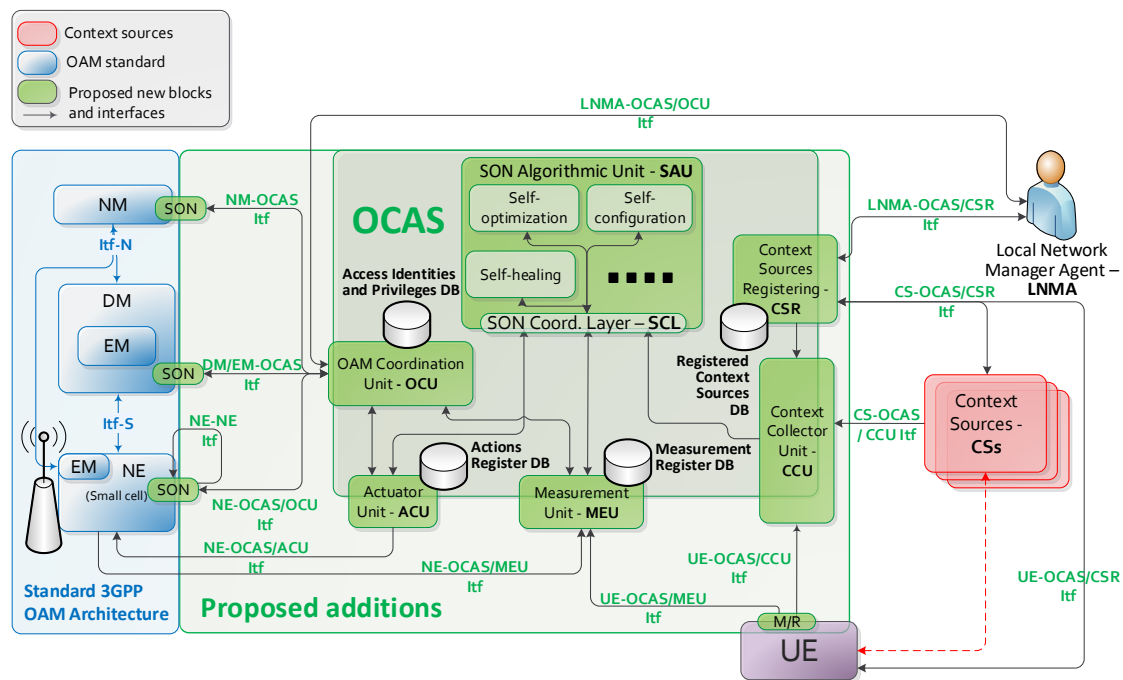

Figure 4.2: Functional OAM Architecture.

The described OCAS roles are distributed in different functional elements, which allow a better insight into the defined functionality:

- *SON Algorithmic Unit* (SAU) implements the local SON algorithms present in the system. It can contain multiple interdependent SON functions for self-configuration, self-optimization (e.g. load balancing or mobility robustness) and self-healing. If multiple SON functionalities are implemented, its *SON Coordination Layer* (SCL) would be also responsible for the proper coordination and trade-off between them. One benefit of the integration in the SAU

of multiple SON mechanism is that it supports the use of the same context sources (as well as network indicators/measurements) for the multiple use cases implemented, reducing the possibility of collisions generated by using different information sources, as well as allowing a straightforward coordination between techniques.

- *Context Sources Registering* (CSR) is in charge of the incorporation and authentication of different sources of context information into the *Registered Context Sources Database*. For a CS to be included, the main parameters for the information exchange with the OCAS must be defined: IP address and format characteristics for the communication with the CS. These parameters should be gathered in a set of profiles to be used by the CCU to communicate with the different available CSs.
- *Context Collector Unit* (CCU) gathers the information coming from the CSs or the terminals registered in the system.
- *Actuator Unit* (ACU) configures the network elements with the new parameters calculated by the location-aware SON algorithms, directly or by the standard OAM pile through the OAM Coordination Unit.
- *MEasurement Unit* (MEU) obtains information from the network elements, by direct network element connection or through standard OAM elements using the OAM Coordination Unit. It is also in charge of the possible acquisition of direct network measurements from the UEs (e.g. received power levels, etc.).
- *OAM Coordination Unit* (OCU) serves as the interaction element between the OCAS and the OAM standard architecture. It translates the configuration orders coming from the ACU into commands for the operator's OAM tools and it turns the OAM monitoring into a format usable by the MEU. Furthermore, it also supports the configuration of any of the OCAS functionalities by commands coming from the standard OAM architecture elements as well as by Local Network Manager Agents.
- *Local Network Management Agent* (LNMA) representing the specific personnel or administrator that may be required to manage the OCAS. The LNMA will have two main capabilities:
  - It may register, via the CSR, new CSs to be used by the OCAS.
  - It may alter the policies and/or functionalities of the OCAS via the OCU. This capability should be restricted through the permissions defined in the *Access Identities and Privileges DataBase* to avoid erroneous/malicious access.

## Interfaces

According to the proposed architecture, the new main block OCAS introduces self-management at the local mobile network. Consequently, new interfaces, protocols and applications should be implemented in order to coordinate this system with the rest of the OAM architecture as well as to measure and modify network devices:

- NM-OCAS and DM/EM-OCAS are used for the coordination between OCAS and the elements of the operator's OAM core.
- NE-OCAS exchanges monitoring and configuration messages between the small cells and the OCAS through three different interfaces:
  - NE-OCAS/MEU focuses on monitoring and providing information about counters, alarms, KPIs, etc., to the MEU.
  - NE-OCAS/ACU carries direct configuration commands or files to the NEs.
  - NE-OCAS/OCU transports both monitoring and configuration messages when these cannot be directly sent/received to/from the NE by the OCAS blocks.
- CS-OCAS interfaces communicate information from the CSs to the OCAS. This includes context messages to support the location-based SON functions (through the CS-OCAS/CCU Itf) and the messages associated to register a new CS in the CSR (through the CS-OCAS/CSR Itf).
- LNMA-OCAS/OCU interface allows (subject to operator permission) the configuration of the OCAS system by the Local Network Manager Agent. In turn, LNMA-OCAS/CSR serves for the manual registration of a CS by the LNMA.
- UE-OCAS logical connections send to the OCAS direct UE monitoring information (through the UE-OCAS/MEU interface) and UE provided context information (by the UE-OCAS/CCU) that may be required for the SAU. For non-cellular external context services, this interface would be UE-dependent, therefore, it may be only available for specific UE models such as smartphones.

All the interfaces connecting the OCAS with standard OAM architecture should follow the same standards as defined for 3GPP interfaces, being mainly based on TR-069 and *Extensible Markup Language* (XML) [176]. CS-OCAS and UE-OCAS interfaces, however, are defined with elements that are independent of the mobile communications OAM network, as they are encapsulated on the mobile user/data plane, so any communication protocol (over IP) can be freely defined for these data flows.



### 4.3.3 SON entity options

Based on the baseline UE report message, the input traffic for the SON entity is estimated. If the context is gathered uniformly from all the terminals, the signaling traffic depends on the *monitoring period* (how often the context is acquired), the *number of UEs in each cell* and the *number of cells managed for the SON entity*. Depending on the SON entity level in the cellular hierarchy, it would cover more or fewer cells.

In this respect, three main possible locations of the SON entity are possible: *cell*, *local* and *core*:

- **Cell SON:** in this approach the base station is the main entity implementing the SON functionalities. This case is limited to distributed or purely one-site mechanisms. Here, the cell would only have to acquire the context from the UEs in its coverage area. For small cells, typically a range from one to a few dozens of UEs. Additional inter-cell coordination would be implemented mainly at local level with close sites (e.g. by X2 interface). However, commonly just a little part of the context information, if any, would need to be exchanged among them .
- **Local SON:** the SON functionalities are performed by an entity in the local area and dedicated to managing multiple cells. Here, the input traffic would be multiplied by the number of cells under the same local element. Considering that this entity will typically cover a large scenario (e.g. a mall, an airport) this would consist of a set of few cells, e.g.: the large office testbed described in Section A.2 consists of 4 cells, the airport scenario presented in Section A.1 has 12 cells.
- **Core SON:** the system is centralized at the core. Hence, the context information for all cells is gathered in such element. A common core covers a range of thousands or tens of thousands of cells.

### 4.3.4 Implementation model for femtocell LTE/LTE-A deployments

The physical implementation of the proposed architecture for LTE/LTE-A systems is focused on the case where the deployed small cells are femtocells. As indicated, this are modeled by HeNBs entities in 3GPP-LTE standards [176].

OAM-SON functionalities follow the standardized 3GPP architecture [52], with the novel addition of the OCAS, which implements local SON context-based func-

tionalties. OCAS implementation can be local (if performed by hardware connected to the same Local Area Network, LAN, as the small cells) or remote (by an external hardware connected to the system via the Internet). Remote solutions have high versatility in terms of using existing or leased equipment. However, the need of exchanging a high amount of information through the often-limited network backhaul, highly encourages the adoption of local implementations as the one proposed here. Challenges for this approach include the need of OCAS additional on-site hardware, its installation and maintenance, although the related cost is expected to be minimal over the total deployment expenses.

Therefore, Figure 4.3 presents the local physical implementation for LTE/LTE-A femtocell scenarios. The DM role is implemented by the *HeNB Management System* (HeMS) [176]. HeNBs user and control planes connect to the operator's core through the S1 interface, while the X2 interconnects the femtocells for distributed cooperation.

In this way, the defined logical links are implemented by physical connections as follows:

- UE-OCAS and NE-OCAS: The information transmitted from the UEs to the OCAS is sent through the Uu interface (as part of its user and control planes) to the femtocell. This data (as well as the commands and information from the BSs transmitted by the NE-OCAS interface) is then retransmitted through the LAN to the OCAS.
- CS-OCAS: The interface used to transmit the UE location information (in case the context information is not directly obtained from the terminals) is implemented by the CSs through the Internet connection of the OCAS.
- NM-OCAS and DM-OCAS: The coordination information between the OCAS and the operator's core (the elements of the standard highest OAM layers: DM, NM) is sent by the router through the backhaul to the operator's core.

The use of LAN for exchanging data between the OCAS and the UEs greatly minimizes the traffic in the backhaul and the operator's core at reduced delay. This traffic local breakout has been envisaged by different manufacturers, standardization bodies [177] and other projects [101] and it is a key factor for avoiding backhaul congestion by offloading signaling traffic, allowing reduced delays and time spans for the proposed context-aware functions.

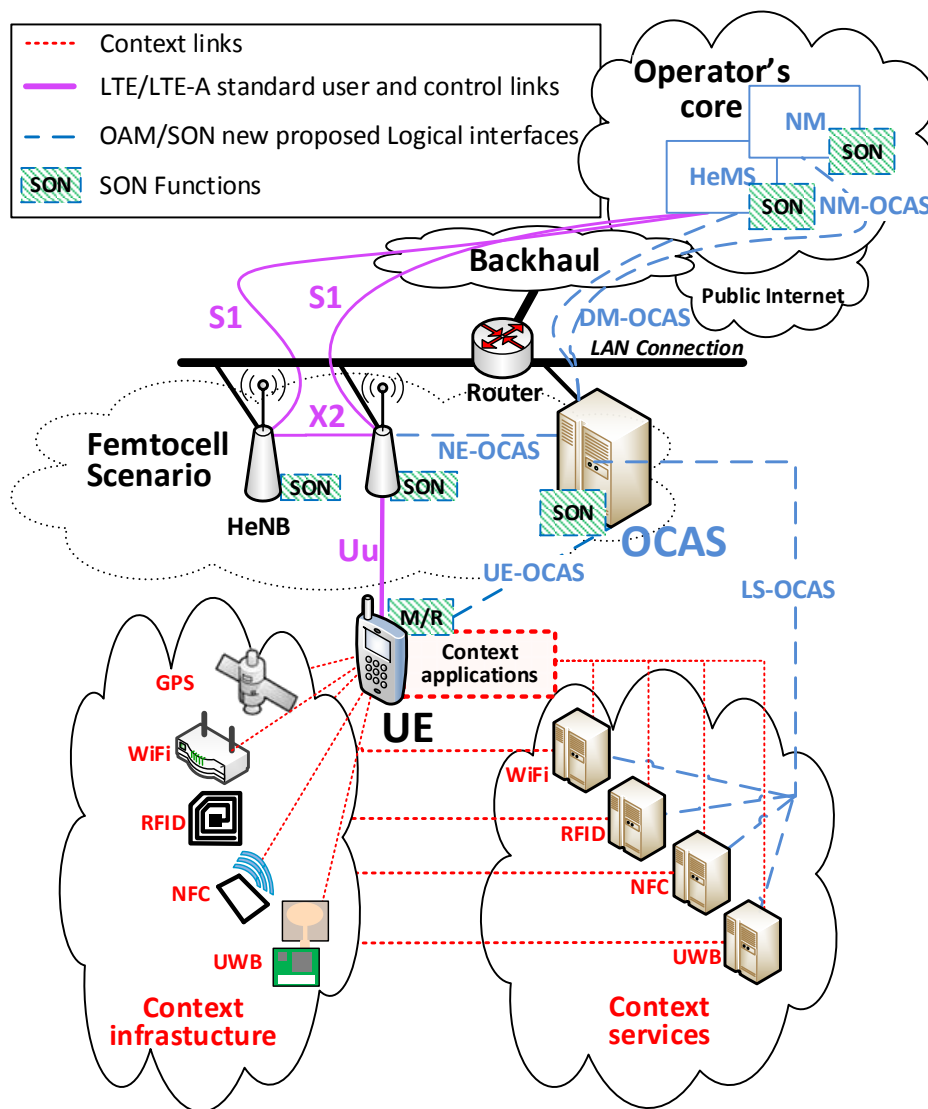

Figure 4.3: Proposed OAM Architecture implementation for LTE/LTE-A femtocells.

### 4.3.5 System responsibility

This characteristic refers to the commercial/legal entity in charge of executing the different context and/or SON functions. The responsible entities include the mobile network operator, the user/administrator of the local system or a third party.

Even if the considered scenarios are essentially local, the small cells are currently part of the mobile network operator infrastructure and make use of its radio spectrum. Therefore, as SON will alter the cells configuration, OCAS should remain on

the operator's domain.

Context information will be part of external systems out of the operator's domain, which may generate some difficulties. For example, UE localization systems may fall out of the scope of the mobile network operator, especially given that positions could be provided independently of the mobile network (e.g. via WiFi, Bluetooth, RFID tags, etc.).

In this way, context sources would typically be in the domain of the user administrator of the local network (e.g. in a corporate building the company owner may manage this subsystem) or by third parties. Taking this into account, if the information coming from the context system is accidentally or maliciously missing/erroneous, the impact on the mobile service provision generated by context-aware SON functions shall be limited. Here, a proper and restricted use of the CSR capabilities is essential to authorize registering of the various sources of data. Moreover, the connections between the OCAS system and the external CSs shall avoid the disclosure (by direct access or simple traffic analysis) of network status information that may be sensitive. Thus, in the interaction between OCAS and the context services, the extent, authenticity, accountability and correctness of the information exchanged will be critical. Standardization on the CS-OCAS and LNMS-OCAS and related processes may be necessary to limit this issue. The same can be said for the context directly gathered from the UEs.

In conclusion, the disparity of the responsible role between the OAM/SON system and the context sources stresses the importance of the security challenges of confidentiality, integrity and availability as presented in Section 4.2.2.

## 4.4 Proof of concept: load balancing

To assess the usefulness of the proposed architecture, different power-based *load-balancing* techniques are defined. Load-balancing techniques aim to achieve a fair distribution in the use of resources between the different cells of an area, in a way that guarantees that none of them gets overcrowded while the rest are lowly used. To do so, different parameters of the cells can be dynamically modified based on the network status, which is estimated by collecting different input indicators from the network.

In our approach, load-balancing mechanism can make use of the features of the proposed architecture as presented in Figure 4.4. In this way, the different indicators (e.g. KPIs) can be read from the network through the NE-OCAS/MEU interface. Based on these inputs, the algorithms are computed by the OCAS-SAU module.

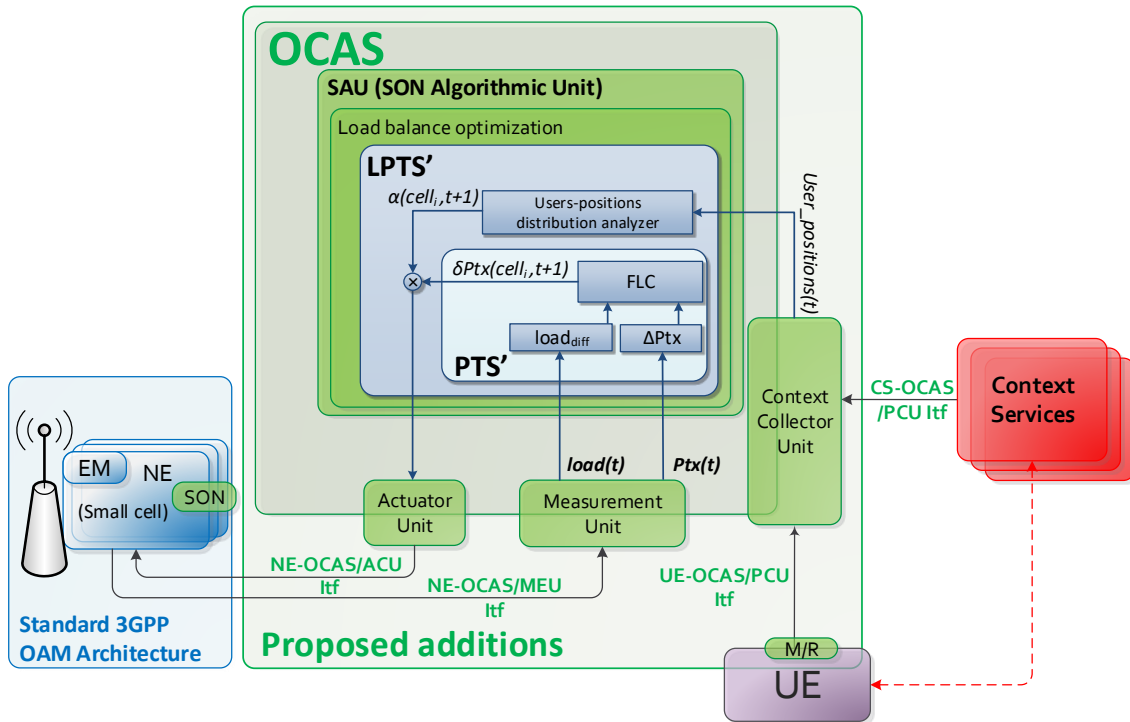

Figure 4.4: PTS/LPTS algorithms scheme.

The required changes in the parameters of the NEs are then sent through the NE-OCAS/ACU interface. The ACU is in charge of adapting these to the required command format for the small cells.

#### 4.4.1 Baseline algorithm

Different load-balancing techniques typically focus on distinct optimization mechanisms or look at different indicators or characteristics to optimize. For the definition of the baseline algorithm for the architecture evaluation, the *Power Traffic Sharing* (PTS) system presented in [178] was used as a starting point. This consisted on an optimization controller that, based on different inputs from the network, estimated new values for the cell parameters following a classic closed-loop control scheme.

The original PTS controller modified the *power budget* (PBGT) handover margins using as inputs the previous PBGT margin values and the blocking ratio of the cells. Conversely, a new system is proposed, labeled as PTS'. PTS' focuses on balance the occupancy of resources between the cells. To do so, at the end of each specific algorithm time span  $t$ , the PTS' system would distribute the load between cells by reducing or increasing their coverage areas. This is done by changing the

transmitted power  $Ptx(cell_i, t + 1)$  for the next period, named as  $t + 1$ , of each small cell  $cell_i$ :

$$Ptx(cell_i, t + 1) = Ptx(cell_i, t) + \delta Ptx(cell_i, t + 1), \quad (4.1)$$

where  $\delta Ptx(cell_i, t + 1)$  represents the change in the transmitted power for the next time span. To calculate the values of  $\delta Ptx$  for each cell  $cell_i$ , two main input indicators are considered. Firstly, its load difference with respect to its adjacent neighboring cells,  $load_{diff}(cell_i, t)$ , defined as:

$$load_{diff}(cell_i, t) = load(cell_i, t) - \frac{1}{|\mathbf{Adj}(cell_i)|} \sum_{\forall cell_j \in \mathbf{Adj}(cell_i)} load(cell_j, t), \quad (4.2)$$

where  $\mathbf{Adj}(cell_i)$  represents the set of adjacent cells of  $cell_i$  and  $|\mathbf{Adj}(cell_i)|$  the number of cells in that set. Here, the load of the cells is calculated as the ratio between the occupied resources and the available ones, measured as the percentage of occupancy of the PRBs assigned to the BSs.

A second input for the  $\delta Ptx(cell_i, t)$  calculation is the current deviation,  $\Delta Ptx(cell_i, t)$ , from its maximum transmitted power  $Ptx_{max}(cell_i)$ :

$$\Delta Ptx(cell_i, t) = Ptx_{max}(cell_i) - Ptx(cell_i, t), \quad (4.3)$$

### Fuzzy logic controller

To calculate the  $\delta Ptx(cell_i, t + 1)$  values from the inputs  $load_{diff}(cell_i, t)$  and  $\Delta Ptx(cell_i, t)$ , a Takagi-Sugeno-Kang *fuzzy logic controller* (FLC) [179] is implemented. This follows the general FLC scheme shown in Figure 4.5.

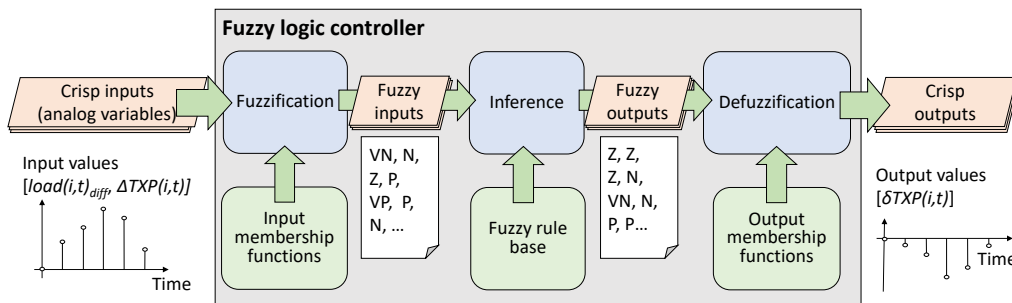

Figure 4.5: Fuzzy logic controller general scheme.

FLCs allow the definition of linguistic rules (e.g. “if X is very negative then Y should be positive”) and their application to real “crisp” inputs (those with precise values, e.g. transmitted power, load) to generate crisp outputs from those rules. This is done in three main steps that will be particularized for our system:

- **Fuzzification:** The inputs membership functions of the FLC (as shown in Figure 4.6a and Figure 4.6b) serve to convert the crisp values of  $load_{diff}(cell_i, t)$  and  $\Delta Ptx(cell_i, t)$  in linguistic variables, such as *very negative* (VN), *negative* (N), *zero* (Z), *positive* (P), *very positive* (VP).
- **Inference engine:** From the fuzzy inputs of the previous stage, it applies the linguistic rules, generating the fuzzy outputs for  $\delta Ptx(cell_i, t + 1)$  as defined in Table 4.3.
- **Defuzzification:** Following the output membership functions in Figure 4.6c, this step generates the crisp output values of  $\delta Ptx(cell_i, t + 1)$  to be updated in each  $cell_i$ . Being a Takagi-Sugeno-Kang FLC, the membership output functions are defined as constant values.

When the presented membership functions and fuzzy rules Table 4.3 follow the ones established in [178], these are particularized for the inputs and outputs defined for PTS’.

Table 4.3: Fuzzy rule base.

$load(cell_i, t)_{diff}$	Operator	$\Delta Ptx(cell_i, t)$	$\delta Ptx(cell_i, t + 1)$
VN	AND	VN	VP
VN	AND	N	VP
VN	AND	Z	P
N	AND	VN	VP
N	AND	N	P
N	AND	Z	P
Z	AND	VN	VP
Z	AND	N	P
Z	AND	Z	Z
P	AND	-	N
VP	AND	-	VN

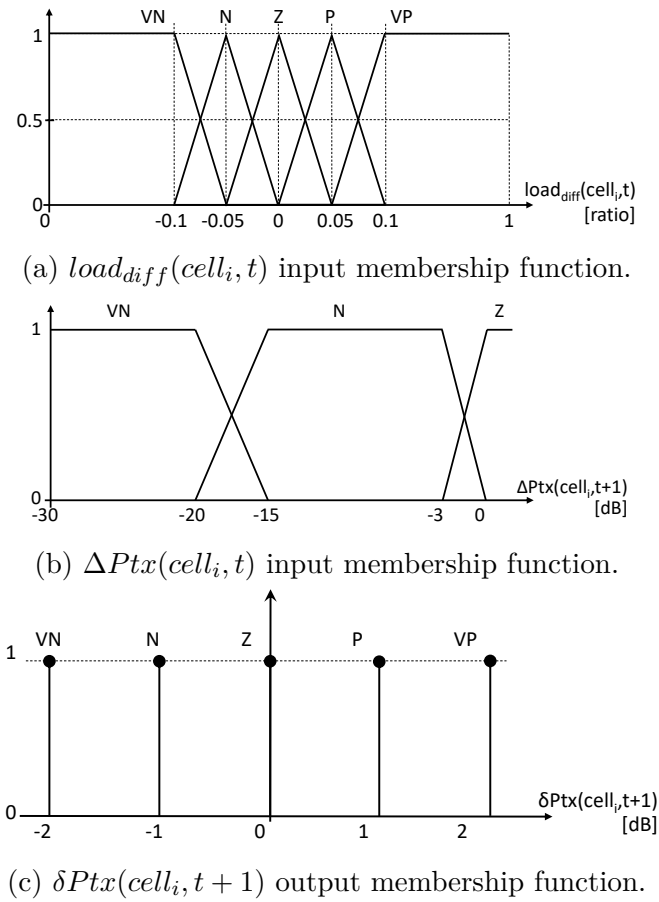

Figure 4.6: FLC membership functions.

### Context-aware SON algorithm

For this type of optimization algorithms, the generated parameter changes, in this case  $\delta Ptx(cell_i, t + 1)$ , tend to be conservative (low) as, without information on users' positions, it is unknown whether each cell would gather more or less users after a transmitted power modification.

Therefore, from the presented PTS' scheme, a novel *location-aware SON algorithm* (LPTS') is proposed, as also represented in Figure 4.4). For the LPTS' the output of the FLC is weighted by a proposed convergence accelerator parameter, represented as  $\alpha(cell_i, t + 1)$ . The value of this parameter is calculated by the *users-positions distribution analyzer* depending on the UEs spatial distribution on the selected cell and its neighboring cells. This block is implemented as part of the OCAS-SAU, being the *user\_positions(t)* input provided by the OCAS-CCU, which would gather the context information directly from the terminals (through

the UE-OCAS/CCU interface) or from context services (CS-OCAS/CCU interface).

A simple function to define  $\alpha(cell_i, t + 1)$  has been defined to assess the presented architecture:  $\alpha(cell_i, t + 1)$  tends to double  $\delta Ptx(cell_i, t + 1)$  values if the users' distribution changes and a concentration of users (more than 50% of them are located in less than the 25% of the small cell area) is detected from one algorithm execution to the next. In consequence, high variations of power would be required to achieve load balance. In any other case,  $\alpha(cell_i, t + 1)$  values are one, thus LPTS' works as the classical PTS' in this case.

Additionally, the local character of the OCAS from both a functional and physical implementation perspective, allows the reduction of the algorithm time span, this means, the time between two consecutive executions of the optimization algorithm and the period used to calculate the indicators of the network.

## 4.4.2 Evaluation

The use of the location information and the reduced time spans are both benefits provided by the architecture independently of the specific SON use case, providing an assessment of the capabilities introduced by the proposed system. Therefore, the presented location-aware load-balancing algorithm, LPTS', is implemented following the proposed architecture. Results are compared with those of previous baseline PTS' algorithm to evaluate the usefulness of the proposed OAM architecture. Also, following the analysis presented in Table 4.2, the results for a "classic" value of one hour are compared to those obtained for a time span of 15 minutes, which is supported by the proposed architecture.

### Set-up

The evaluation of the presented use case algorithm is performed by the dynamic system-level LTE simulator described in Section A.1. As the started point of the research, the simulated scenario presented in [41] was used. This consists in a 50x50 meters building with 5 floors, representing a typical corporate environment. Four small cells are deployed in the 3rd floor where users' movements present a variable accumulation of users in dense work areas, coffee talks, etc.

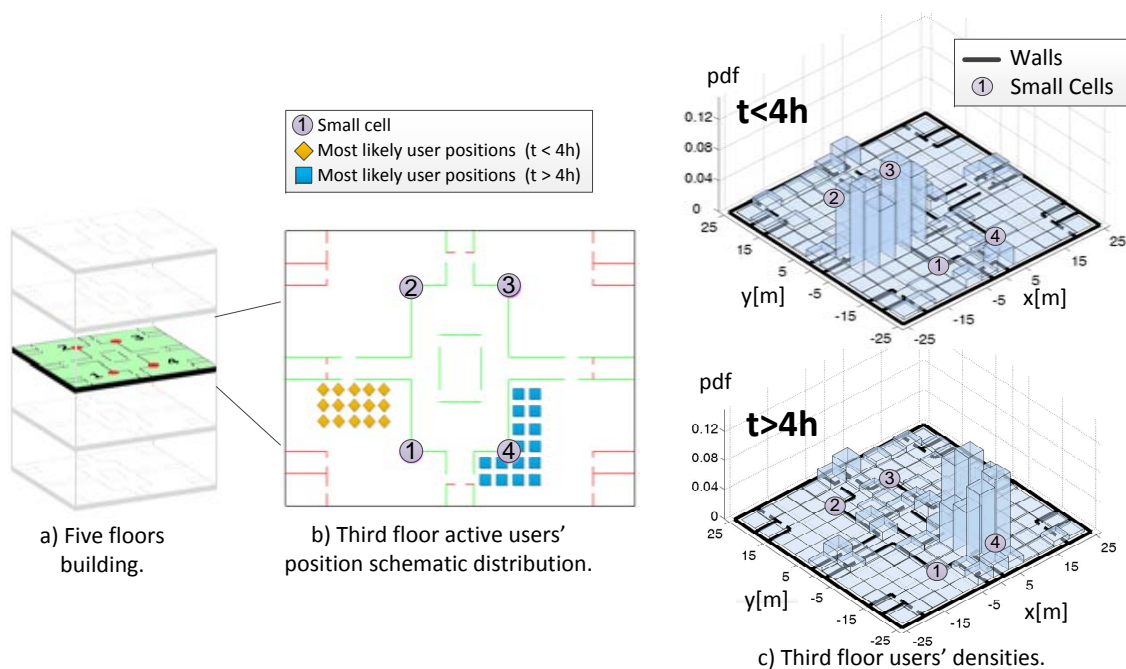

Figure 4.7: Spatial user distributions in the scenario (3<sup>rd</sup> floor).

As relevant use case, a realistic daily users' position distribution is defined: during the first 4 hours of the simulation, small cell number 1 is heavily loaded in its north area (i.e. cell covering a working session room). During the next hours ( $t > 4h$ ), active users gather mainly in a narrow spot (at the bottom in 4.7) in the south-west area of neighboring small cell 4 (i.e. cell covering the coffee room).

## Results

The simulations show the performance for the different self-optimization mechanisms and time spans presented:

- Without SON: without applying optimization.
- PTS'-1hour: baseline PTS' technique without localization information and using a long time span (1 hour). This is the case typically implemented in classic OAM architectures.
- PTS'-15min: PTS' using a reduced time span (15 minutes), supported by the proposed architecture.

- LPTS'-1hour: Location-based PTS' mechanism where users' locations are provided by the proposed architecture. It uses long time span.
- LPTS'-15min: Algorithm that makes use of both the reduced time span and the location-awareness supported by the proposed architecture.

To assess the quality of the optimization the main analyzed KPIs is the *Unsatisfied User Ratio* (UUR). This is a common measure of the overall performance of the network defined as the linear combination of OR and CBR in the way [41]:

$$UUR = CBR + OR(1 - CBR), \quad (4.4)$$

where the *call blocking rate* CBR is the relation between the number of blocked calls to the number of calls that attempt to access the network due to lack of resources or not enough signal quality. The *outage rate* (OR) is the probability that an existing network connection is in standby mode before it is finished. This means the ratio of unserved connection time due to temporary lack of resources ( $OR_S$ ) or bad *Signal-to-interference-plus-noise ratio* (SINR), represented as  $OR_Q$ . In this way,  $OR = OR_S + OR_Q$ .

Figure 4.8 presents the simulations results, where the impact of the proposed architecture (availability of users' location and short periods to trigger the SON mechanisms) is observed in the evolution of the UUR indicator.

Before the change on the users' distribution ( $t \leq 4h$ ), SON mechanisms exhibit better network performance (around half of the UUR value) than the situation without SON. Also, it is observed how reduced time span solutions provide better results for the same SON mechanism. On average, the 15 min solution enhances the overall network performance compared to the 1 hour ones as they are able to achieve a better adaptation to network temporal variations.

Once the variation in the user concentration has occurred ( $t > 4h$ ), the new condition leads to an even more degraded situation for the network without SON, with an increase in the average UUR from 12% to 26%. Meanwhile, the defined SON mechanisms can optimize and update configuration parameters in order to balance the network, reducing the UUR.

On the one hand, the graph shows how classic architectures implementing SON (PTS'-1hour) improves network performance compared to the case without SON. However, the adaptation to variations in users' distribution takes a long time (7 hours). The reduced time spans (PTS'-15min) supported by the proposed architecture accelerate that convergence period to 105 minutes. Furthermore, an improvement on UUR values is observed: final UUR average of 11% for 15 min span

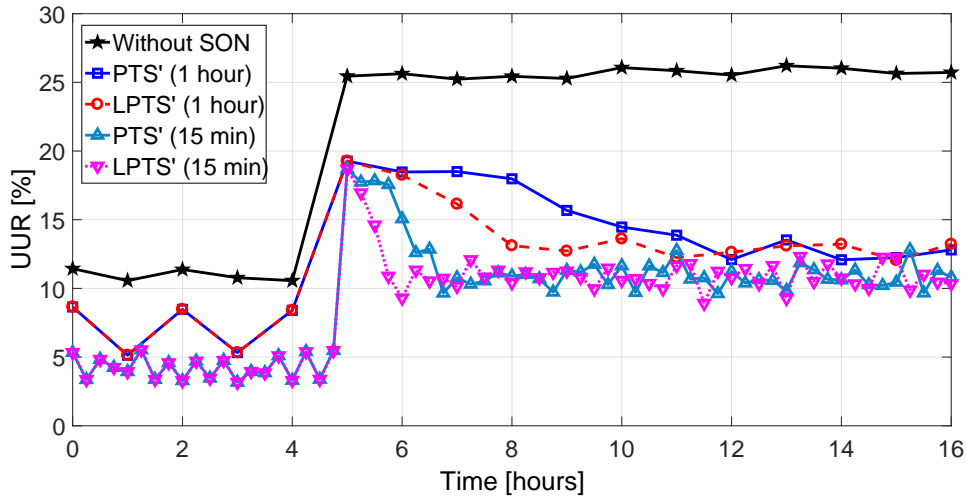

Figure 4.8: Comparison of impact on performance of a change in the users' distribution for the different optimization and architectural approaches.

compared to 13% for time spans of 1 hour. On the other hand, considering the use of localization, for equal time spans in SON mechanisms, LPTS' converges to optimum values more than twice as fast than previous SON functions (PTS').

In this way, LPTS'-15min algorithm supported by the provided architecture converges around 9 times faster (taking 45 minutes) than classic SON mechanisms, providing also a reduction of around one third in the UUR values. Additionally, it should be noticed that, if users' concentration is continuously changing, it would be the only algorithm able to properly tackle these fluctuations keeping proper network performance.

## 4.5 Context traffic assessment

One of the most consideration before adopting context-aware SON techniques is the amount of signaling required for context management (acquisition, dissemination, etc.). This would depend on a range of factors.

Firstly, as seen in Figure 4.1, the links affected by the signaling will be the ones between the context source and the element which implements the SON mechanisms (or *SON entity*), this means the entity that compiles the acquired context information and computes the context-based algorithm.

Secondly, the specific signaling messaging. Multiple protocols can be defined for

the coordination and request of context between the cellular network elements and the context sources (i.e. periodical or on-demand context acquisition). In any case, the report of the context data itself, from its source to the SON entity, will be the most capacity consuming step.

Thirdly, the study focuses on terminals as context sources, being the most numerous and the ones that makes use of the cellular radio access. Here, H2H UEs are considered the terminals with a wider and higher amount of data. Meanwhile, MTCs often make use of alternative access options (personal area networks based on WiFi, Bluetooth...) and intermediate concentrators.

With these considerations, the subsequent analysis focuses on the signaling introduced by UEs context reporting. Different SON entity alternatives are evaluated, considering the expected traffic and capacity of key cellular network configurations.

### 4.5.1 UE context report

JSON is widely considered a powerful format for transmitting data objects with multiple attributes, as it requires less characters than XML. It also allows efficient reading by javascript. Hence, a baseline JSON UE context-report message is proposed as presented in Table 4.4.

The proposed UE report message provides the input context information required for most of the UE context based SON algorithms analyzed in the literature. In its three initial fields, it indicates the message type, the context source type and its identifier. Then, it presents the values of a baseline set of main UE context variables: id, time (“hhmmss.ss, dd, mm, yyyy” format), location, velocity, orientation (azimuth, pitch and roll), battery level (%), and app in use.

Parameters, such as terminal type, do not change in time and therefore could be transmitted just once: consequently, they have not been included in the message. Where other nomenclatures can be applied, location is defined in terms of the coordinates (x, y, z) relative to a specific indoor scenario identified by its area\_id. Global coordinates (e.g. GNSS) could be included instead (e.g. the area\_id could indicate in that case that the coordinates are global). The field “id” used to identify the UE can be the IMSI or a completely random number assigned during the logon procedure, anonymizing the data.

Assuming UTF-8 encoding (the most common for JSON), the message would be equivalent to around 300 bytes. To compare it with user traffic values, a TCP+IP communication header is assumed (TCP+IPv6=60 bytes), giving a protocol overhead of 31% (larger message payloads would have lower overhead ratios).

Table 4.4: JSON UE context report message example.

```

1  {
2  "message_type": "UE_CTX_REPORT",
3  "source_type": "UE",
4  "source_id": "470010171566423",
5  "context_variables": {
6      "id": 470010171566423,
7      "time": "141530.00,04,07,2015",
8      "area_id": "618641324",
9      "x": 14.21,
10     "y": 85.62,
11     "z": 1.00,
12     "velocity": 5.40,
13     "azimuth": 59.30,
14     "roll": -6.20,
15     "pitch": -43.60,
16     "battery": 85.00,
17     "app": "SocialAp"
18 }
19 }

```

## 4.5.2 Comparison with cellular networks capacity

Figure 4.9 presents the estimated SON entity input traffic (in Mbps) necessary to manage one (x1), ten (x10) and a thousand (x1000) cells, being these values in the range of magnitude that we can expect for the three presented SON entity approaches: cell, local and core SON, respectively.

These traffic values are calculated given the average number of UE context reports per second and per cell. For example, if the monitoring period is one second, the x-axis indicates the number of reporting UEs. In this respect, context variables as dynamic as UE position typically require fast monitoring. Some approaches to SON algorithms propose monitoring periods in the range of one second, which is consistent with the needs declared by SON-aware systems presented in other works and the requirements of the SON mechanisms to be described in further chapters.

To minimize costs while not risking the service, cellular infrastructure links are commonly deployed to cope with expected traffic demand. In this field, the NGNM provides estimated cell user-plane throughputs, distinguishing between *busy-time mean* and *quiet-time peak* traffic for different UMTS, LTE and WiFi radio access configurations [180]. From these values, last mile and backhaul are provisioned

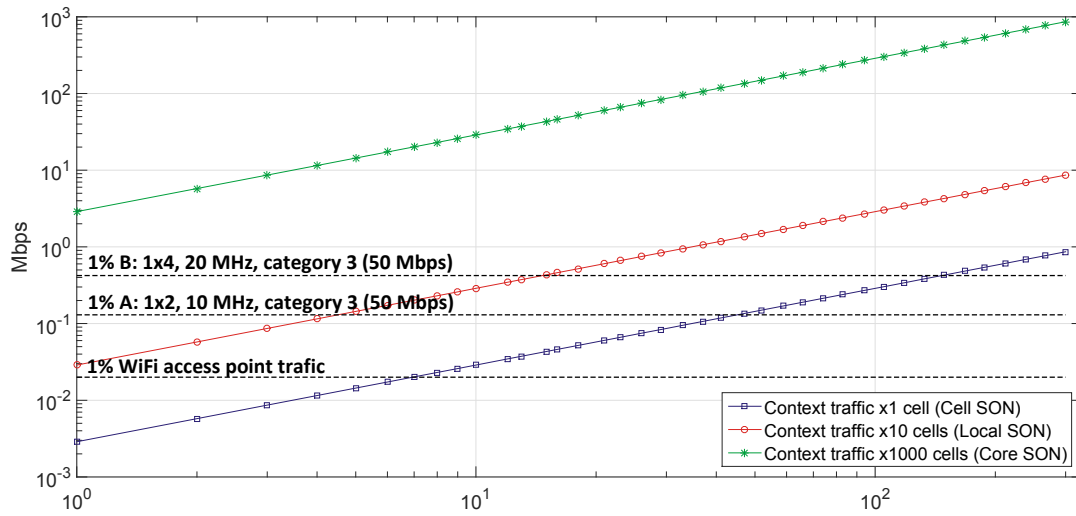

Figure 4.9: Signaling costs and baseline user plane cell throughput for LTE small cells.

adding the estimated protocol overhead and the control and management plane signaling.

Following [180], the backhaul capacity provisioning is defined by the rule: provisioning for  $N$  cells =  $Max(\text{peak}, N * \text{busy time mean})$ . In this way, the capacity allocated for multiple cells would be mainly determined by the expected busy-time mean traffic. In this way, the context traffic should not go above a reduced percentage of the expected user-traffic to be supportable by the existing networks. A conservative approach would be to consider a restriction of the 1% of the busy-time mean user-plane traffic for the context-related traffic.

This restriction is represented in Figure 4.9 by the horizontal lines indicating the 1% of the NGNM estimated busy-time mean user-plane traffic. Two main uplink LTE configurations are considered: configuration A,  $1 \times 2^2$ , 10 MHz, category 3; and configuration B:  $1 \times 4$ , 20 MHz, category 3 [180]. For the WiFi case, the 1% of an operator managed hotspot typical backhaul profile is provided [180].

Analyzing the context traffic for one cell, x1 in Figure 4.9, it is observed how for WiFi access, the amount of information that can be acquired is limited to 7 UEs reports/s per access point. For LTE access, this number increases between 45 and 150 reports/s per cell, which is consistent with the number of users commonly served

<sup>2</sup>MIMO configurations are described with “TxR”, being “T” the number of transmitter antennas and the “R” the number of receiver ones

for one small cell. If the context signaling is constrained in this way, the last mile and backhaul described provisioning guidelines would ensure that they will also be able to manage the context traffic (e.g. the plotted context traffic x10 cell). This makes applicable both cell and local SON approaches when the context is obtained from the UEs or other local sources.

However, with this monitoring level if the SON functionalities are implemented at the core or obtained from external sources, the traffic transmitted through the cellular core network and/or to be computed by the core SON entity would be large. Assuming the context traffic x1000 cells and 150 reports/s per cell, it would amount around 430 Mbps. Aggregation mechanisms in the lower elements might allow some reduction on this number, however the a priori asynchronous and irregular nature of the UE reports would reduce the possible benefits.

The core network would typically have enough capacity to support this traffic (considering that it is expected to be below the 1% of the baseline user plane traffic). Nonetheless, it would imply an important amount of dedicated resources. Also, its computation would require a huge capacity as it can include very costly procedures (e.g. JSON parsing, multi-variable processing, source fusion, etc.).

Based on this analysis, the local and cell SON implementations are deemed desirable. In these, if context is obtained from external sources, traffic breakdown techniques could help to minimize the amount of information transmitted through the core. Similar approaches can be also defined if the external context data is directly obtained by the cells or by a local entity. In this way, LIPA and SIPTO techniques can be used if the context is first obtained by the UEs from local or remote external context sources, respectively.

## 4.6 Conclusions of the chapter

In this chapter, the particularities of the integration between context and cellular information have been described, as well as the main use cases and context information sources.

Based on this, the challenges for systems integrating both SON and context have been identified. A novel OAM architecture extension for 3GPP was then proposed for medium/large indoor small cell scenarios with available context information. Its design has been justified considering multiple architectural characteristics, features and options.

Moreover, the impact of timing and context-awareness in SON mechanisms has been analyzed based on a key use case. The results showed that the proposed



architecture leads to a significant improvement in the response time by using context-awareness and it also advocates for the use of reduced time spans for these functions. Furthermore, the approach has been discussed and assessed regarding its signaling impact, where a baseline UE context report message is defined. From this study, firstly, the achievability of high context monitoring rates (e.g. one UE report per second) for common cellular configurations, number of UEs managed per cell and backhaul provisioning guidelines has been confirmed. Secondly, the usefulness of the proposed local and distributed approaches instead of core-centralized ones was reassured.

## Part III

# Context-aware self-healing



UNIVERSIDAD  
DE MÁLAGA

# Chapter 5

## Context-aware self-healing framework

### Content

---

5.1	Motivation . . . . .	90
5.2	Framework . . . . .	90
5.2.1	UE-profiling based model . . . . .	91
5.3	Proof of concept: cell outage detection . . . . .	94
5.3.1	Statistical profile generation . . . . .	94
5.3.2	Detection and diagnosis algorithm . . . . .	96
5.3.3	Non-context mechanism . . . . .	96
5.4	Test trial . . . . .	97
5.4.1	Set-up . . . . .	97
5.4.2	Evaluation . . . . .	98
5.5	Conclusions of the chapter . . . . .	101

---

From the prior assessment on the importance and usefulness of context information, a novel framework able to support context-aware self-healing mechanisms is identified in this chapter. This is deemed indispensable to allow the development of novel algorithms able to cope with the characteristics of small cell indoor scenarios.

In this way, Section 5.1 introduces the general motivation of the chapter. Section 5.2 defines a self-healing framework and its specific model to support the individual processing of UE collected information. Then, a specific algorithm based on the statistical analysis of the received signal profiles is defined in Section 5.3 and



implemented and evaluated in a real scenario in Section 5.4. Finally, Section 5.5 provides the final conclusions of the chapter.

The content of this chapter has been partially published in the following work:

- S. Fortes, A. A. Garcia, J. A. Fernandez-Luque, A. Garrido, and R. Barco, “Context-Aware Self-Healing: User Equipment as the Main Source of Information for Small-Cell Indoor Networks,” *IEEE Vehicular Technology Magazine*, vol. 11, pp. 76–85, March 2016.

## 5.1 Motivation

As described in Section 3.2.4 works on self-healing have mainly focused on macro-cells and pure network related data. The work presented in [29] defined a general framework for self-healing. However, it did not address the specific features for the indoor case or the use of context aware information for such task. The work in [30] also presented a general framework, together with the definition and analysis of some macrocell indicators for failure diagnosis.

The study presented in [31] also introduced a framework for automatic detection, where specific algorithms to support failure management were developed. However, again the applicability of context information or their application to indoor small cell scenarios was not addressed. Further work [32] introduced some improvements in the previous approach. In the conclusions, the possible need of using context information was indicated. However, no development or definitions at this respect were included in the work.

Some of the works detailed in Section 3.3, in particular [149][150][151] proposed the application of context for end-user service adaptation. However, none of the previous references analyzed either the particularities of self-healing in small cell deployments or the potentialities of using context-awareness for self-organizing networks or self-healing purposes.

## 5.2 Framework

For the definition of the context-aware self-healing framework, its general interactions and procedures should be identified. In this way, it will include context information coming from external sources, as well as network monitoring data obtained from the UEs. UEs shall be able to report classical mobile communication

indicators (e.g. received power, serving cell identifier) and context information alike (e.g., time, position, activity, etc.).

In this way, different functional elements are identified as the key components of the self-healing framework:

- The **indicators acquisition** block is in charge of collecting measurements coming from the network infrastructure and the user equipment and generating *indicators* of the current performance. For this it could use also the current context as an input.
- The **context acquisition** block obtains the context from each terminal and also complements it with data obtained from other external sources of information such as positioning servers, work scheduling applications, etc.
- The **context aggregation** block is in charge of associating the current context with previously recorded situations. Different algorithms can be adopted to define a similarity score between current terminal context and recorded ones. Once such association is performed,
- The **inference engine** block is dedicated to the actual detection of network problems as well as the diagnosis of their causes based on the data from the previous two blocks.
- Finally, the **record update** block is in charge of storing the database of historical KPI measurements. It also updates it based on the reports gathered during system operation.

Following this scheme, UE context information can be used to address the identified challenges for self-healing in small cell scenarios. First, small cells reduced monitoring capabilities are compensated by the direct UE analysis performed by the context and indicators acquisition blocks. Based on the obtained information, the context aggregation and inference engine blocks support the context-based analysis. This allows identifying variations that would not impact common performance metrics due to cell overlapping. As it will be shown in next sections, meaningful indicators can be calculated even for scarce and variable UE distributions, avoiding the false conclusions that would result from the classic analysis of quick performance variations.

### 5.2.1 UE-profiling based model

Following these functional blocks, different approaches for processing the input data could be adopted. Figure 5.1 details the internal scheme for the proposed approach.



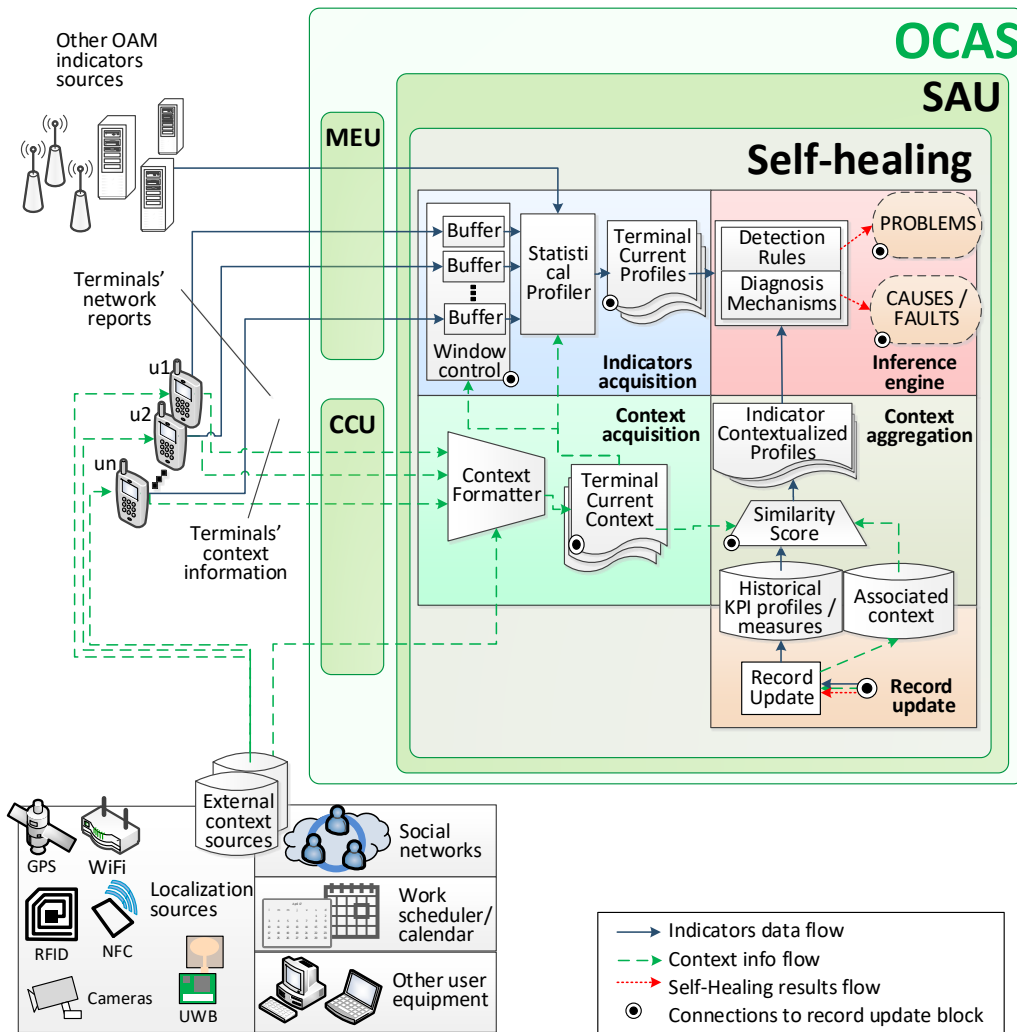

Figure 5.1: Context-aware self-healing framework.

This is designed based on the statistical profiling of UE network data based on its context.

For this model, the activities of the functional elements are detailed below:

- the indicators acquisition block accumulates the network reports from the UEs in independent buffers. From the measurement/values accumulated in one buffer, a subset is selected as the *profiling window*, i.e. the group of samples to consider for the analysis. A *window control* system should establish this window in a way that the number of measurement is large enough to allow discarding spurious behavior as well as short enough to allow quick response to

network dynamics. The context shall be as well consistent for all the samples in a profile, so that when it significantly changes (e.g., by the user abandoning a room) old samples are discarded.

- the context acquisition calculates the contextualized profile of the indicator, i.e. the distribution of the KPI for previous situations with the same context.
- the inference engine makes use of the deviation between each KPI current distribution in comparison to the recorded contextualized profiles obtained from the context aggregation block.

Figure 5.1 represent this model of the self-healing framework assuming that is implemented as part of the general SON architecture described in Chapter 4. However, it could rely on any system providing the necessary inputs. Here, OCAS elements are abstracted for clarity, focusing on the representation of the self-healing block. The network parameter measurements and the context information will be received in the OCAS by the *MEasurement Unit* (MEU) and the *Context Collector Unit* (CCU) respectively. These blocks adapt them to a format suitable for the *SON Algorithmic Unit* (SAU) and the self-healing system in particular.

However, the introduction of context involves by itself a set of challenges as the need of accessing and processing heterogeneous sources and data formats. Such challenges are mostly overcome by centralizing context acquisition through terminals, as current smartphone applications can easily act as concentrators of multiple information sources.

Regarding the overhead introduced by the proposed system, the main restriction would come from the amount of information gathered from the terminals, which would be transmitted through the air interface of the cellular system. However, part of this information consists of the network related terminal indicators and such data is already exchanged with the base stations as part of the standardized control plane procedures. Regarding the context information, the technical feasibility (e.g. from the point of view of the introduced signaling overhead) have been assessed in Section 4.5.

In terms of the physical implementation of the presented framework, this can be performed at various levels of the OAM architecture. A straightforward solution includes its collocation in standard OAM elements, as the NM or the DM (see Section 2.3). However, due to the local nature of much of the context information (e.g. indoor positioning systems commonly cover a particular scenario/area), local implementations are recommended in order to minimize the overhead of the system backhaul and allow fast response. In this way, the proposed system could be computed in a distributed manner in the small cells themselves or being deployed

in a locally connected central element (e.g. a server or a master small cell), an implementation scheme akin to the one defined in Chapter 4.

As our first analysis in Section 3.4 showed, localization is a key context parameter for improved self-healing mechanisms. Therefore, for the applicability of the proposed approach one indispensable asset is the availability of positioning information. Current market trends [168] indicate that user localization is becoming commonly available at indoor scenarios. Other context sources, such as surveillance cameras imaging, social networks, meeting calendars, etc., can provide also localization as well as other context information (e.g., utilization of resources, estimated user concentrations, etc.).

## 5.3 Proof of concept: cell outage detection

Based on the proposed framework, a method for statistical profile generation as well as a novel cell outage detection mechanism is defined in this section as shown in Figure 5.2.

### 5.3.1 Statistical profile generation

In this implementation, the current UE context is gathered by the context acquisition block (step 1 in Figure 5.2). Then, the context aggregation block obtains historical measurements for different cases (e.g., normal behavior) corresponding to the current context (e.g. time of the day, level of occupancy, location, etc.) and builds the contextualized profile,  $\hat{p}_{ctx}(m, ctx(ue))$ , for a certain indicator or KPI,  $m$ , measured by the UE,  $ue$ . This is done by generating the statistical distribution of the measurements with the same context contained in the historical KPI and associated context databases. For example, if the UE is in a specific room, previous measurements obtained in the same room are considered in the calculation of the KPI contextualized profiles. In parallel, the current terminal profile,  $\hat{p}_{term}(m, ue)$ , is obtained by generating the statistical distribution of the measurements contained in its profiling window.

For generating the statistical profiles, multiple options are available, from the simple histogram of the measurements to an approximation by means of a mathematical distribution. In our case, the epdf is generated by beta distribution estimation, which has many advantages for statistical modeling [181], such as being defined by only two parameters (which reduces the memory costs of storing the distributions) as well as having a normalized value range (between  $[0, 1]$ ), allowing the direct definition of inference mechanisms with the same values for different KPIs.

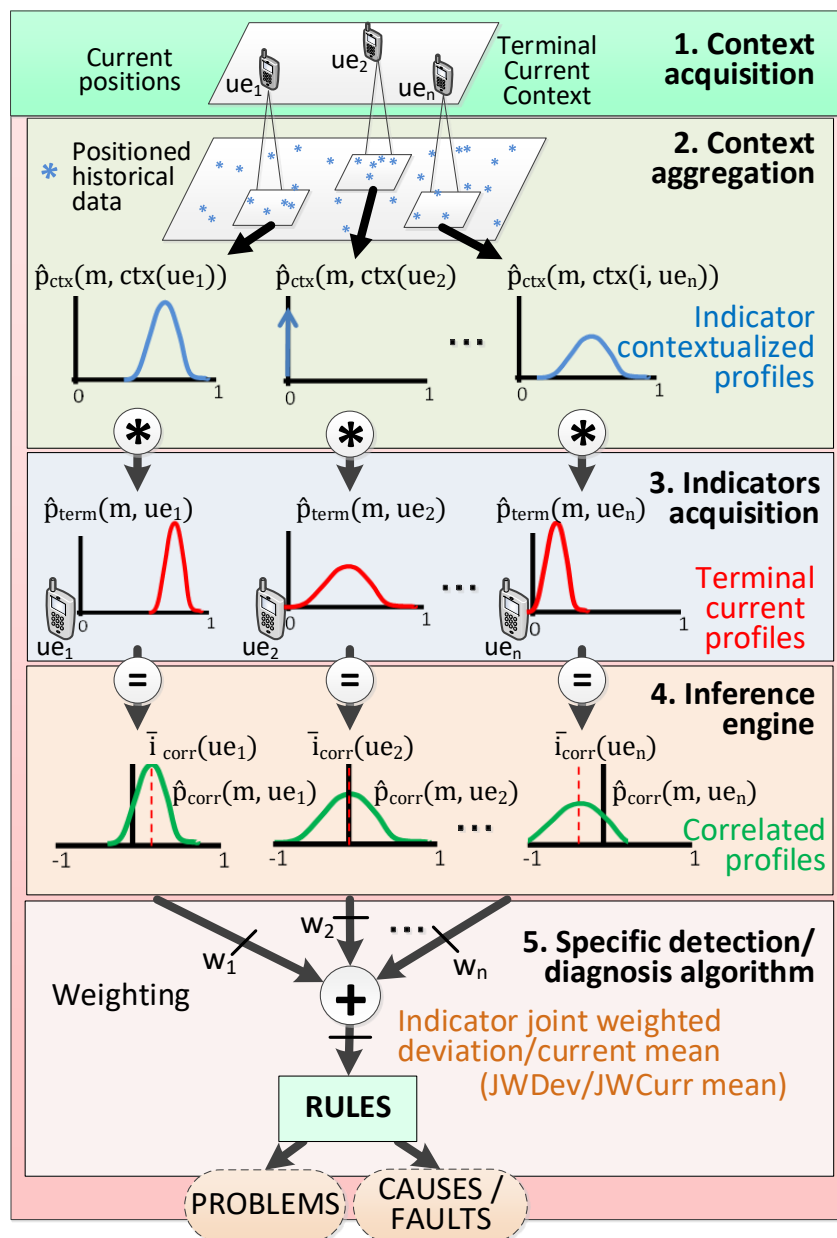

Figure 5.2: Scheme of classic and proposed context-aware detection/diagnosis algorithm.

### 5.3.2 Detection and diagnosis algorithm

After this, the comparison between the contextualized historical indicator profiles and terminals' current profiles can be done by multiple algorithms, from the difference in the average value of the indicator (its mean) [31] to more complex metrics [32], or mechanisms [182]. The defined framework is algorithm-agnostic, allowing the implementation of any mechanism for this task.

As an initial approach, the use of the correlation between the contextualized profiles and the terminal KPI current profile is proposed. The resultant correlated profile,  $\hat{p}_{corr}(m, ue) = \hat{p}_{ctx} * \hat{p}_{term}$ , is equivalent to the statistical difference between the previous case baseline and the current distribution.

As a second step in the comparison, also a simple mechanism is proposed. Here, the mean of each terminal correlation,  $i_{corr}(m)$ , is calculated and weighted depending on the user terminal trustworthiness, which depends on the accuracy of its available localization sources and previous measurements. After this, the means of each terminal profile correlation are added. The resultant indicator is defined as the *joint weighted deviation mean* (JWDev-mean) of each indicator ("joint" because it reflects the measures from multiple terminals and "weighted" due to the weight performed to each mean before adding them).

Over the value of the JWDev-mean of different indicators, different thresholds intervals can be defined as a set of rules to detect and diagnosis the status of the network, as presented in Figure 5.5, allowing both the detection of network problems and the diagnosis of failure causes. In general, since more than a single indicator may be used for diagnosis, the rules may consider several resulting weighted deviations.

### 5.3.3 Non-context mechanism

For the analysis, it is deemed necessary to evaluate the presented algorithm in comparison with the non-context aware case. To do so, a non-context indicator, the *joint weighted current mean* (JWCurr-mean) is defined. Such indicator is the result of calculating the weighted average (where in this case the weights would not be based on context) of the current profiles for an indicator, jointly measured by the UEs. This represents the KPI that would be used for non-context self-healing solutions. Its calculation is equal to obtain the JWDev-mean power but applying only the stages 3 and 5 shown in Figure 5.2.

## 5.4 Test trial

### 5.4.1 Set-up

Here, the general framework and algorithms presented in the previous sections are evaluated in a real large office area (55x25 meters) where four femtocells have been deployed (see Figure A.3). This testbed is further described in Section A.2. Given the non-availability of LTE equipment and frequencies by the time of the tests, UMTS femtocells were used. The use of UMTS or any other RAT instead of LTE does not introduce any important change in the application of the proposed system. The specific definition for indicators often varies between RATs, which may imply the need to redefine the specific rules for detection/diagnosis. However, the methods for generating the current and contextualized profiles and their correlation are equally applicable for all indicators.

Fault cases are executed in periods of around twenty minutes starting from a normal behavior status. Then, the specific fault is manually generated (e.g. by unplugging a femtocell) or via software re-configuration (e.g., change of configured transmitting power) leaving the femtocell in such faulty condition for a period of 5 minutes. After this, typically the cell takes around two minutes to recover from the fault and it is left 10 additional minutes of normal behavior before a new failure is executed.

As also detailed in Section A.2, terminal reporting is based on a proprietary Android app, while in final implementations it may also be based on 3GPP standard control plane messages [183]. In this testbed, the presented system framework has been installed in a common remote server that receives the terminal reports and performs the detection/diagnosis calculations in real time (see Figure A.4). The context of a specific mobile consists on the time of the day and terminal position. Position information is assumed to be known with 3 meters accuracy, being this consideration consistent with localization mechanisms available nowadays [184]. Taking this into account, the contextualized profiles are generated based on the previously recorded RSCP values in the area of 3 meters surrounding the UE present position.

For the tests up to four terminals, which move simultaneously in the scenario, report each second the cell id and the RSCP of serving and adjacent cells, where multiple user distributions area analyzed. Figure 5.3 represents the evolution of one specific terminal RSCP reports, where femto\_x1 is in outage for the periods  $t \in [4, 11] \cup [21, 28]$ .

In the figure, it can be also observed how femto\_x4 is received only in the periods where femto\_x1 is in outage. This is because femto\_x1 does not receive femto\_x4

and it does not have it in its neighboring list. When the UE starts to be served by femto\_x2, which has femto\_x4 in its list, it starts to be reported by the terminal.

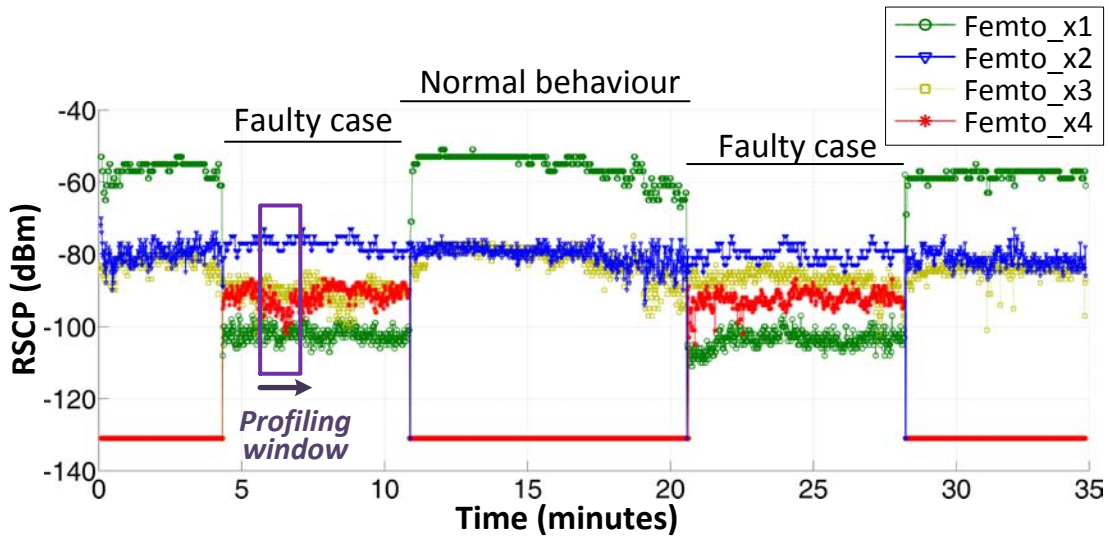

Figure 5.3: Evolution of indicator RSCP gathered by one terminal.

## 5.4.2 Evaluation

With the information gathered from the terminals (distributed as shown in Figure A.3), classical non-context mechanisms would not be able to provide trustable diagnosis: on the one hand, without context information, it is not possible to distinguish between a power reduction from the serving cell femto\_x1 caused by a failure or by a normal movement of the terminal, e.g. when it is at the cell edge. On the other hand, the non-reception of any other cell, as femto\_x4, could also be erroneously considered as an indication of failure. Therefore, it would be not possible to define an algorithm solely based on the RSCP values and able to properly distinguish between a normal no reception of a cell and a failure case. This can be observed in Figure 5.4, where the evolution of the non-context indicator JWCurr-mean power indicator is presented.

From the figure, it can be noticed how it would be not possible to define a proper mechanism for real time detection of cell outage based only on this non-context information. For example, any threshold based analysis would assume a failure in femto\_x4 during a large part of the periods ( $t \in [0, 4] \cup [11, 21] \cup [28, 35]$ ), where no failure was present. This is marked as “femto\_x4 false fault positives” in Figure 5.4. Also, the femto\_x1 low values in the failure part of the samples ( $t \in [4, 11] \cup [21, 28]$ ),

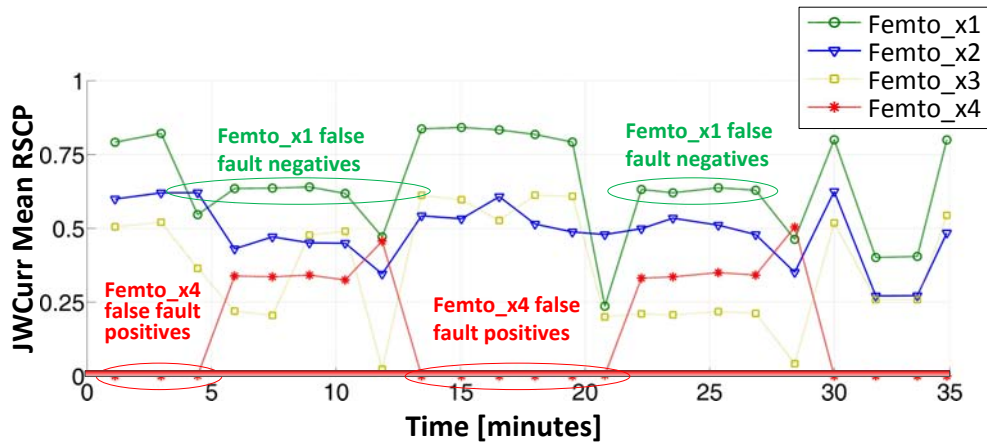

Figure 5.4: Joint Weighted Current Mean RSCP.

marked as “femto\_x1 false fault negatives”) would not be considered as a failure without context information (when actually it was faulty), as this fact can be only identified by knowing that its received power should be much higher.

Instead, the context-aware algorithm presented in the previous section is applied in real time operation of the testbed, as shown in Figure 5.5. Here, the correlation between current and historical contextualized profiles (for normal situation) is shown in two main cases:

- For the failure case of femto\_x1, the correlation indicates a high deviation from the normal situation, which allows the detection of the cell outage.
- For the normal behavior of femto\_x4 (which is in normal behavior during all the test), the contextualized historical profile is centered in the origin, reflecting that for the current context the terminal may not receive power from femto\_x4. In this way, the correlation with current measured profile provides a null deviation.

Finally, Figure 5.5 represents the final JWDev-mean of the RSCP, indicating the threshold considered for the detection and where the profiling window has been set to one minute. These thresholds are defined by human expertise as a ratio of deviation in the JWDev, e.g. cell outages are detected if  $JWDev < -0.4$ , indicating a degradation of more than 40% with respect to the expected contextualized value.

In Figure 5.6, the presence of spurious threshold crosses of the joint weighted mean deviation can be observed. This is due to the temporal loss of the signal received from close cells in the period where the UE change its serving cell. Such

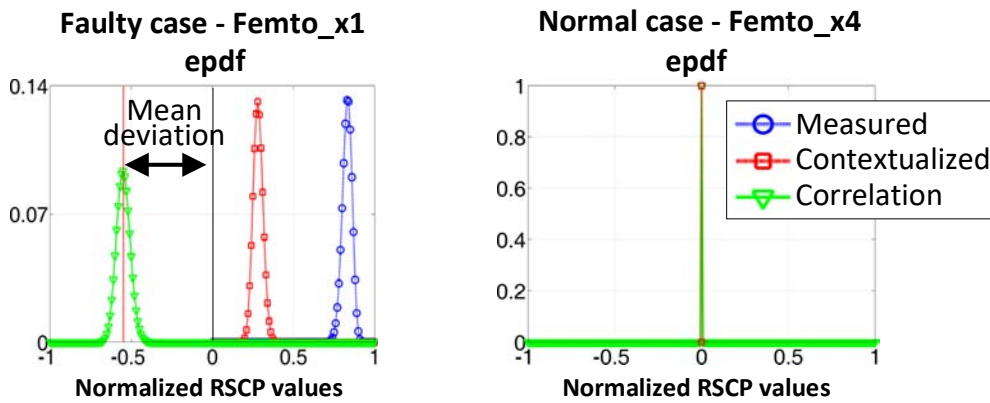

Figure 5.5: Correlation between indicator contextualized profiles and terminal current measurements distribution.

spurious crosses (as the one of femto\_x3 around  $t=21$ ), which can lead to false positives, are avoided by considering that a rule is satisfied if the associated threshold is crossed at least twice. Increasing the profiling window size can be also a solution to avoid such spurious behavior at the cost of increasing the time required to generate each new value of JWDev, thus such approach was not applied.

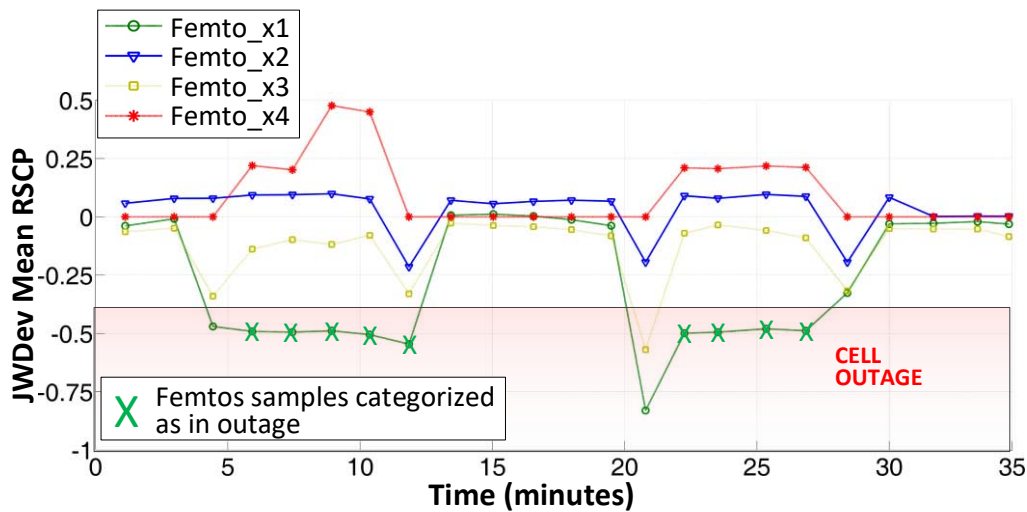

Figure 5.6: Joint Weighted Deviation Mean RSCP.

With these considerations, Figure 5.6 shows how the algorithm efficiently carries out real time detection based on the terminal reported information. The system avoids completely the generation of false positives or negatives while maintaining a reduced response time (lower than 2 minutes).

## 5.5 Conclusions of the chapter

This chapter has presented a novel approach for context-awareness applied to self-healing in mobile cellular networks. From the analysis provided in the previous chapter a self-healing framework has been proposed to integrate context information in small cell networks. Supported by this framework, a specific UE-profiling based model and context-based detection algorithm has been defined.

The proposed system has been implemented in a real femtocell deployment, demonstrating the capabilities of the developed approach. Here, the use of UE context supports the automatic analysis of network measurements, distinguishing between normal power degradations (due to location and mobility) and failure related ones. It also supports the fusion of the information gathered by different terminals and the joint categorization of the status of the cells.

The specific framework model might imply some limitations when considering scenarios with many terminals for each small cell, as the calculation of the terminal current profiles is defined for each individual UE. This imply relevant changes of approach in comparison with previous KPI-based mechanisms, including the use of time buffers and the storage of individual UEs context history. To cope with this, an alternative approach is defined in the following chapters, as well as alternative self-healing functions based on them.



UNIVERSIDAD  
DE MÁLAGA

# Chapter 6

## Contextualized network indicators

### Content

---

6.1	Motivation . . . . .	104
6.2	Contextualized indicators . . . . .	106
6.2.1	Statistics calculation . . . . .	107
6.2.2	Weight masks . . . . .	108
6.2.3	Binary weights . . . . .	109
6.3	Context-aware diagnosis . . . . .	110
6.3.1	Training phase . . . . .	111
6.3.2	Online phase . . . . .	111
6.3.3	Data scarcity avoidance . . . . .	113
6.3.4	Diagnosis scheme . . . . .	113
6.4	Implementation considerations . . . . .	115
6.4.1	Hybrid and distributed approaches . . . . .	115
6.4.2	Classifier inputs selection . . . . .	116
6.4.3	Mask information sources . . . . .	117
6.4.4	Re-training needs . . . . .	118
6.4.5	Computational cost overview . . . . .	119
6.5	Diagnosis evaluation . . . . .	120
6.5.1	Learning phase . . . . .	122
6.5.2	Online Phase . . . . .	126
6.5.3	Impact of localization error . . . . .	131
6.6	Conclusions of the chapter . . . . .	132

---



This chapter presents a novel approach for integrating context information into self-healing. This is achieved by defining the *contextualized indicators* approach, which combine performance measurements and UE context information. These indicators have the advantage of being easy to integrate in current detection and diagnosis mechanisms. The proposed approach can be applied indistinctly for macro and small cell environments. However, as the rest of the thesis, this chapter is focused on indoor small cell scenarios, as they are the more challenging from a self-healing perspective, and therefore the ones that can benefit the most from the proposed mechanism.

In this way, Section 6.1 identifies the need for the contextualized indicators approach as a way to introduce context information into current self-healing mechanisms. From this, the main contributions of this chapter are: firstly, the establishment of the mathematical formulation of this approach in a comprehensive manner that allows the definition and application of any particular set of context sources by defining different *context masks* (in Section 6.2); secondly, the integration of these contextualized indicators into a diagnosis model (Section 6.3); thirdly, the analysis of the implications of the proposed approach from a computational and architectural way and from the perspective of both users and operators (Section 6.4). Section 6.5 assesses the defined approach, evaluating the capabilities of the approach for a key simulated scenario. Finally, Section 6.6 describes the main conclusions of the chapter.

These contributions have been the focus of the following publications:

- S. Fortes, R. Barco, A. Aguilar-García, and P. Muñoz, “Contextualized indicators for online failure diagnosis in cellular networks,” *Computer Networks*, vol. 82, pp. 96 – 113, April 2015.

## 6.1 Motivation

Based on the cellular sources of information described in Section 3.2.2, the classical mechanism for network monitoring is presented in Figure 6.1 - left column. Here, the term *indicator* will be used indistinctly to refer to any metric gathered from the network (alarm, counter or KPI), although the focus will be in statistical KPI-like ones.

For such an approach, the performance analysis is based on indicators at NE level, typically for each cell. An indicator of this type will be represented as  $F_{cls}$ , where a set of them would be represented as  $\mathbf{F}_{cls}$ . These indicators are typically generated by statistical analysis of UE-related *samples*, which are associated with



UE measurements (e.g. received power) or events (blocked calls, drops).

In this classical view, the set of samples used for calculating the value of the indicator,  $f_{cls}[t]$ , depends uniquely on the *observation period*  $t$ , when they were gathered and the serving cell of the reporting UEs. In the figure, these samples are represented as  $m'(ue, \tau)$ , where  $ue$  indicates the terminal of origin of the sample and  $\tau$  the time of acquisition. Using different measured variables  $M$ , applied statistics and serving cells lead to generate multiple indicators, which would be the inputs for the SON algorithms.

The process of generating the indicators from the different samples or events is classically transparent for the network operator, the indicators being automatically generated by the OAM system or supporting tools, providing in consequence a value of  $f_{cls}[t]$  for each  $t$ , for example each hour<sup>1</sup>.

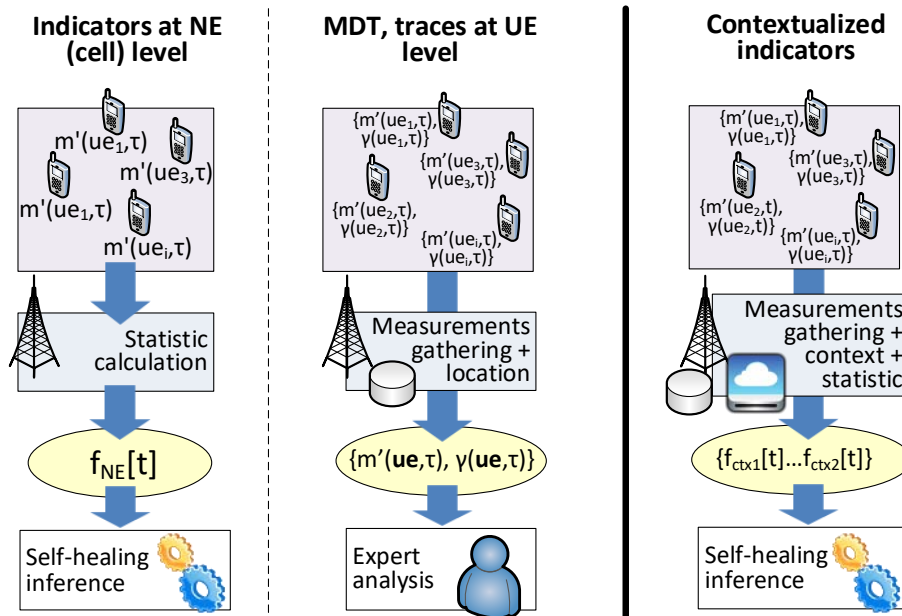

Figure 6.1: Classic and proposed contextualized approaches for the generation of indicators.

As analyzed in previous chapters, the use of direct information at the UE level could help to overcome those issues. Classically these reports are obtained from particular UEs by subscriber traces, drive test, MDT or over the top applications. Such information allows analyzing the service performance of specific terminals, where the

<sup>1</sup>When referring to time-dependent metrics, “ $(\tau)$ ” would indicate continuous values of time, e.g. whenever a measurement is gathered. “[ $t$ ]” however would represent the index in a periodic indicator, e.g. the value of an indicator for the period 11:00 - 12:00.

indicator can be enriched with additional context information. This typically this consists in the UE location obtained in drive tests and MDT, represented in Figure 6.1 - central column as  $\gamma(ue, \tau)$  for any UE  $ue$  at a specific instant  $t$ . However, the analysis of the context of such data has been until now mainly based on human expert analysis, which is extremely time consuming. Also, the manual approach lacks the required automation for fast response to network failures.

## 6.2 Contextualized indicators

Given the limitations of the described previous approaches, the construction of *contextualized indicators* is proposed for network analysis, where both UE radio measurements and context are used to generate the indicators (as shown in Figure 6.1 - right column). To do so, the mathematical expressions related to such indicators are defined.

In this way, each value  $f_{ctx}[t]$  of a contextualized indicator  $F_{ctx}$  would be defined as a function, of the UE's gathered values of a variable  $M$  and their context  $\gamma$  during the gathering. For the proposed approach this would be defined as:

$$f_{ctx}[t] = \hat{\theta}(\{m'(ue, \tau), \gamma(ue, \tau) | \forall ue \in UE_{\mathbf{SC}}, \forall \tau \in t\}), \quad (6.1)$$

where  $\hat{\theta}$  represents any statistic (e.g. mean, percentile, sample size) estimator or algorithm based on both measurements  $m'(ue, \tau)$  and their related context  $\gamma(ue, \tau)$ . Here,  $ue$  refers to a specific UE of the set of network reporting terminals,  $UE_{\mathbf{SC}}$ . Contrary to classic indicators at cell level, these UEs do not have to be served by a unique cell, but UEs served by any cell of a set  $\mathbf{SC}$  can be included.  $\tau$  represents the instant of measurement in the observation period  $t$ .

The context of one UE is composed of distinct categories and values, such as location, user category, service conditions, etc.:

$$\gamma(ue, \tau) \sim \{x(ue, \tau), y(ue, \tau), z(ue, \tau), sc(ue, \tau), \dots\}, \quad (6.2)$$

where  $x, y, z$  represent the position of the UE when the measurement was gathered and  $sc$  indicates the serving cell. Many more context parameters can be defined, such as current demanded quality of service, trustfulness in the terminal report, terminal orientation, speed, etc. Some of this context information can be directly received from the terminal or they may be estimated from other parameters. For example, UE speed, if required, may be calculated from previous position reports.

This method greatly differs from that presented in Section 5.3, where the measurements of each particular terminal are analyzed based on historical positioned data. Thus, a certain period of time would be required to start generating meaningful data about each UE. This made that approach more dependent on the recorded database of previous samples and on the mobility of each terminal. Also, it implied the use of individual buffers of the samples gathered from each UE.

### 6.2.1 Statistics calculation

Once the collection of measurements and context for a certain period has been obtained, how to generate the contextualized statistic implemented  $\hat{\theta}$  should be defined.

For this, the use of *sample weights* is proposed for this task. Sample weights are a concept applied in the field of population statistics and social polling [185]. In social polling, sample weights are mainly used to tame the effect of heterogeneous sampling likelihood of a specific population group. However, they have not been, to the best of the authors' knowledge, previously applied in cellular networks monitoring.

The use of this approach allows to calculate any desired statistic (mean, percentiles) from both measurements and context. In the proposed approach, sample weights are used as a way of increasing the impact of some measurements compared to others on a certain contextualized indicator. This concept is based on the idea that the reports gathered under certain context (e.g. from a specific area, or terminal) would have higher relevance in the detection and diagnosis of certain failures.

To illustrate this, the sample weights concept is applied to the calculation of the contextualized epdf,  $epdf_{ctx}$ , of a set of UE reported measurements  $M'$  for an observation period.

Here, the epdfs used to demonstrate the application of weights for the generation of any statistic-based indicator. This means, using the weighted statistic of the multiple measurements in one observation period. This is not to confuse with later statistical profiling of multiple indicator values which is going to be used in the inference of network failures.

Here, the definition of epdf provided by [175] as a function of the different measurements and the Dirac delta function  $\delta$  is used:

$$epdf_{ctx}(m) \Big|_{M'} = \frac{1}{E_w} \sum_{\forall m' \in M'} \delta(m - m'(ue, \tau)) \cdot w(\gamma(ue, \tau)), \quad (6.3)$$

where  $w(\gamma(ue, \tau))$  represents the weight related to the context  $\gamma(ue, \tau)$  of a

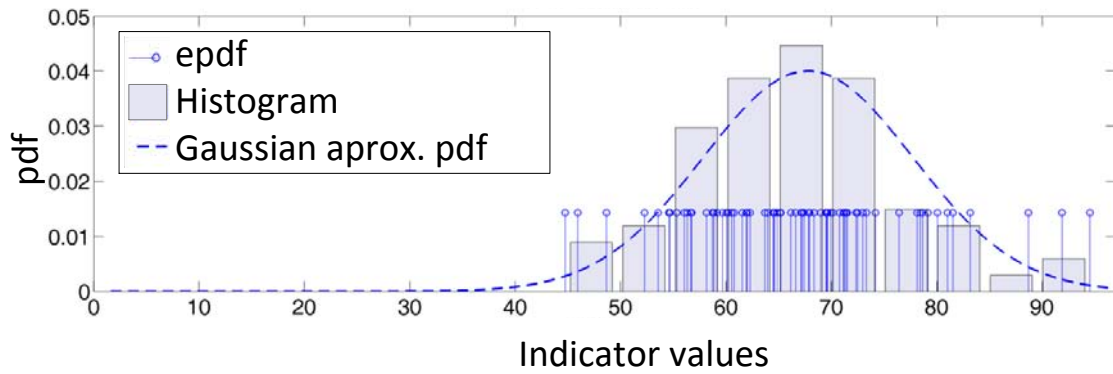

Figure 6.2: Empirical pdf, histogram and associate approximate normal distribution.

certain measurement  $m'(ue, \tau)$ . The expression is normalized dividing it by  $E_w$ , representing the sum of all the weights applied to the set of measurements  $M'$ :  $E_w = \sum_{\forall m' \in M'} w(\gamma(ue, \tau))$ .

Therefore, weights will have an impact on the estimated distribution of measurements by giving higher or lower importance to some samples. This delta-based epdf can be used as input for the most common histogram of the set or for approximating an underlying parametric (Gaussian, beta, etc.) or non-parametric distribution of the measurements (see Figure 6.2).

From this, any statistic (as the mean, Xth percentile, variance, etc.) can be calculated to generate the contextualized indicator values. Also, direct analytical expressions for the weighted version of the statistic (e.g. the weighted mean) can be applied, avoiding the  $epdf_{ctx}(m)$  calculation.

### 6.2.2 Weight masks

To simplify weights calculation and increase their applicability, the *context masks* concept is also introduced. A context mask defines a relation between a context attribute and a set of weights. For example, a *location mask* may define sample weights as inversely proportional to the UE distance to the serving base station.

In the same way, masks can be defined based on network variables. For example, a *service mask* can consist in discarding (weight 0) all terminals that have no visibility (no received signal) from a certain cell.

Also, different context masks could be defined for the same context attribute. Thus, a context mask could apply lower weights to samples far from the cell station

position, increasing the importance of close samples for issues related to the base station proximity. Conversely, another mask could define a higher weight for positions close to the external walls/windows of the building, thereby increasing the importance of border effects.

The multiple context masks contribute to the *total weight*,  $\mathbf{w}_T(\gamma(ue, \tau))$ , applied to each sample. This can be defined as a *combination function*  $\phi$  of the multiple weights generated by the simultaneously applied context masks:

$$\mathbf{w}_T(\gamma(ue, \tau)) = \phi(\{w_{loc}(\gamma_{xyz}(ue, \tau)), w_{sc}(\gamma_{sc}(ue, \tau)) \dots\}), \quad (6.4)$$

Each possible combination of context masks implies the generation of a specific contextualized indicator, as represented in Figure 6.3, multiplying the number of possible indicators available for self-healing. In this figure, the top part reflects the classic approach, where one indicator is directly generated by a network element (e.g. base station) in a transparent way. In the proposed approach (bottom) different contextualized indicators can be calculated depending on the set of context masks applied to the UE measurements. In this case, each indicator value is computed based on the weighted UE measurements received during an observation period.

### 6.2.3 Binary weights

The weights of a context mask can be specified as any function of the context attributes. As a useful option, the use of binary weights, which can only have a value of 0 or 1 for any context variable, is proposed:

$$w(\gamma(ue, \tau)) = \begin{cases} 1 & \text{if } \gamma(ue, \tau) \text{ met } w \text{ defined conditions} \\ 0 & \text{otherwise} \end{cases} \quad (6.5)$$

This is equivalent to discard or accept certain samples depending on their compliance to a given condition. For example, if the position of the terminal is inside a certain area. This solution is good in terms of simplicity and fast computation, but it eliminates the possibility of finer weights (e.g. gradual increase in the weight of a sample depending on its distance to a base station).

This approach is especially useful for context masks based on *geographical areas*. This way, just the samples measured in certain regions can be included in the calculation of a contextualized indicator. The cell center, its edge, the building border, etc., are areas whose statistics are especially interesting for diagnosis purposes. Binary weights are also appropriate for selecting samples obtained from terminals served just by specific cells or meeting certain conditions.

For the generation of a total weight, their combination function  $\phi$  can still be freely defined by any function of the different weight masks. However, if only binary weights are used, these can be easily combined by logical operators such as AND/OR. The total weight can therefore define the intersection or the union set of measurements satisfying different context masks.

For binary weights, the calculation of the epdf would not be required to obtain any context statistics, as these can be calculated directly over the original samples  $M'$  by simply discarding the measurements with total weight equal to 0, reducing the computational costs of the process.

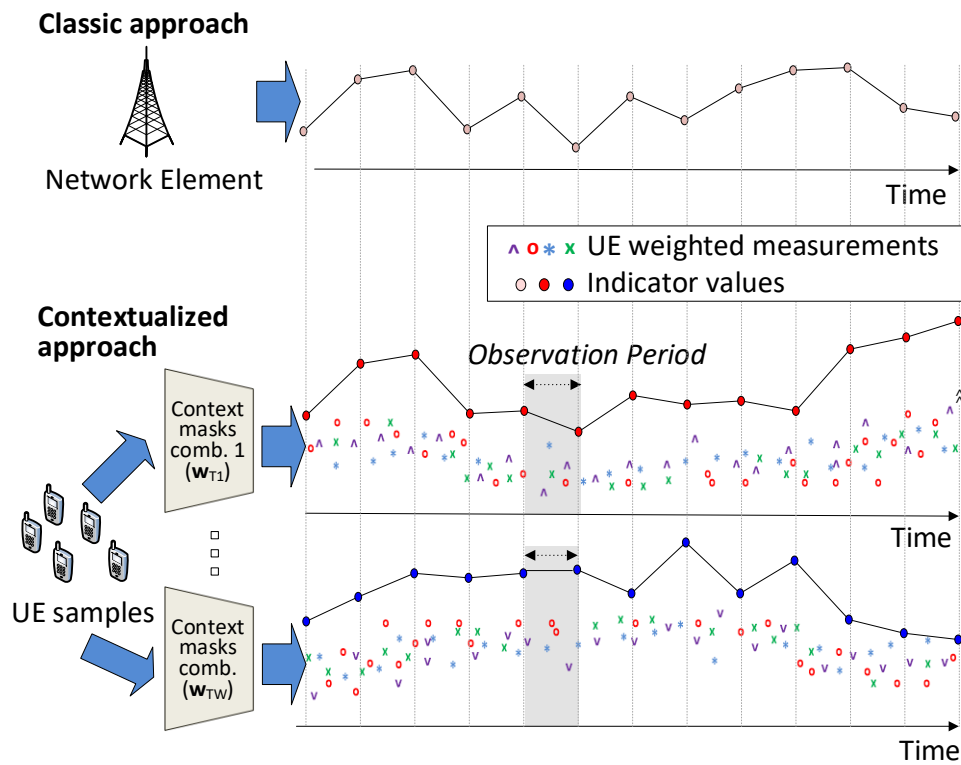

Figure 6.3: Classic and proposed approached for the diagnosis inference mechanisms.

### 6.3 Context-aware diagnosis

Once the contextualized indicators have been defined, they must be integrated in the diagnosis process. Here, a diagnosis scheme based on a naive Bayes classifier is presented and adapted.

Such a mechanism, as well as any statistical based diagnosis system, requires a *training phase*, where the system adapts to the network conditions and its expected outputs under different network states. Then, the system is used for the diagnosis of failure causes during the *online phase*.

### 6.3.1 Training phase

For the diagnosis of the specific failure cause, the current values of the indicators have to be compared with the *statistical models* of the indicators. These models are constructed during the *training phase* that is commonly performed offline, this means, prior to the application of the system to the working network.

Following the framework presented in [29], models consist of the estimated *conditional probability* of each indicator value given a certain *network state*: a normal status or a specific failure cause.

Hence,  $\hat{p}(F_{ctx}|C = c_s)$  represents this estimated conditional probability for the values of the indicator  $F_{ctx}$  given a specific network state  $C = c_s$  (e.g. normal status, interference from a cell, etc.).

To calculate this probability, the indicator values for different *labeled periods*, periods where the specific failure cause / state of the network is known, are gathered. Based on the equally labeled values of this training set, the conditional probabilities are calculated approximating their function by a parametric (e.g. Gaussian, beta) or non-parametric distribution (e.g. ks-density, normalized histogram) [181].

### 6.3.2 Online phase

The online phase of the diagnosis system can be applied using the information directly gathered from the network during its operation, therefore its denomination as “online”. In the online phase, the failure cause affecting the network is identified by comparing the current indicator values to the models generated during the learning phase. To do so, the values of one or multiple indicators shall be compared to the statistical profile generated in the learning phase for such indicators.

This comparison may be performed following different inference mechanisms. Here, a naive Bayes classifier is proposed as a baseline diagnosis method [181]. A naive Bayes classifier is based on the use of the Bayes’ theorem assuming strong independence between the features.

In this way, the classifier can be expressed as:

$$\hat{p}(C = c_s | \mathbf{F} = \mathbf{f}[t]) = \frac{\hat{p}(C = c_s) \prod_{F \in \mathbf{F}} \hat{p}(F = f[t] | c_s)}{\hat{p}(\mathbf{F} = \mathbf{f}[t])} \quad (6.6)$$

where  $\mathbf{F}$  is the set of *input indicators*, contextualized or not, from the same or different measured variable or generated by different context masks, e.g.  $\mathbf{F} = \{F_{cls1}, F_{cls12}, \dots, F_{ctx1}, F_{ctx2}, \dots\}$ .

For this set,  $\mathbf{f}[t] = \{f_{cls1}[t] \dots f_{ctx1}[t], \dots\}$  is the *evidence*, composed of the set of indicator values in the  $t$ th observation period.

For a possible network state  $C = c_s$ ,  $\hat{p}(C = c_s)$  indicates its *prior probability* and  $\hat{p}(C = c_s | \mathbf{F} = \mathbf{f}[t])$  represents its *posterior probability* given the evidence  $\mathbf{F}$ .  $\hat{p}(F_{ctx} = f_{ctx}[t] | c_s)$  is the conditional probability of the indicator input  $f_{ctx}[t]$  given the case  $c_i$ , which is calculated from the models obtained in the learning phase.

The term  $\hat{p}(\mathbf{F} = \mathbf{f}[t])$ , the probability of the evidence, being equal for all  $\hat{p}(C = c_s | \mathbf{F} = \mathbf{f}[t])$ , can be discarded for the comparison between different outputs of the classifier.

Equation (6.6) can be applied assuming the independent computation of the probability distributions for each KPI, avoiding the calculation of multidimensional joint probability distributions that would be required if independence was not assumed. Although being a simple mechanism, naive Bayes classifiers have demonstrated good performance in a huge variety of situations, even when independence between the features is not guaranteed [186]. Once the classifier returns the posterior probabilities, inference of the network state can be based on a simple *maximum a posteriori* (MAP) decision rule, consisting in selecting as the estimated network status  $\hat{c}[t]$  the one with maximum posterior probability, which provides the results for the diagnosis method.

For this approach, each time the diagnosis system receives the values of the indicators for a period  $t$ , these are analyzed without considering previous or posterior samples. This allows to generate a diagnosis for each period with just one value of each considered indicator. Additional mechanisms making use of the time series evolution could also be used with contextualized indicators. For example, that presented in reference [32]. Here, an *observation window* is used for the most recent indicator values. However, such time series approaches may lead to an increase in the time needed by the algorithm to diagnose and imply higher computational costs. Therefore, their application would be reserved to further studies.

### 6.3.3 Data scarcity avoidance

The use of context masks, especially binary ones, could lead to having not enough UE measurements to calculate a contextualized indicator. If there are not enough measurements that meet the conditions of an applied set of context masks (for example there are no users on the edge of a cell), the value of the contextualized indicator could not be calculated for the period.

That situation could occur also for classical indicators, for example if a cell does not serve any UEs for a period. However, as the context masks can impose more restricted conditions, this problem may become more serious. To reduce the impact of such situations, this work proposes three different approaches:

- *Discard indicator*: Avoid using the affected indicator for the period without samples. However, having less indicators for the classification may lead to a reduction in the diagnosis accuracy.
- *No diagnosis*: If one of the selected indicators as input of the classifiers has no value, the system avoids providing any diagnosis result. This reduces the risks of providing erroneous results, while increasing the periods without answer and possibly increasing fault response delay.
- *Fallback*: A substitute input for the naive Bayes classifier is selected for the periods where the primarily selected indicator has no value. This substitute can be another contextualized or classic indicator. In this way, the system can keep providing diagnosis results while at the same time trying to maintain accuracy.

The choice between the three techniques would depend on the OAM requirements and limitations in terms of accuracy and capacity to process and store multiple models and indicators.

### 6.3.4 Diagnosis scheme

The complete diagram of the presented approach is represented in Figure 6.4. As shown in the figure, the system follows a simplified application of the self-healing framework presented in Chapter 5: here the individual buffer-based statistical processing of the measurements of each UE is replaced with the contextualized indicators approach.

In this way, the network measurements  $\mathbf{M}'$  and the collected context information for all terminals,  $\mathbf{\Gamma} = \{\gamma(ue_1, \tau_1), \gamma(ue_1, \tau_1) \dots \gamma(ue_2, \tau_1) \gamma(ue_2, \tau_2) \dots\}$ , are processed

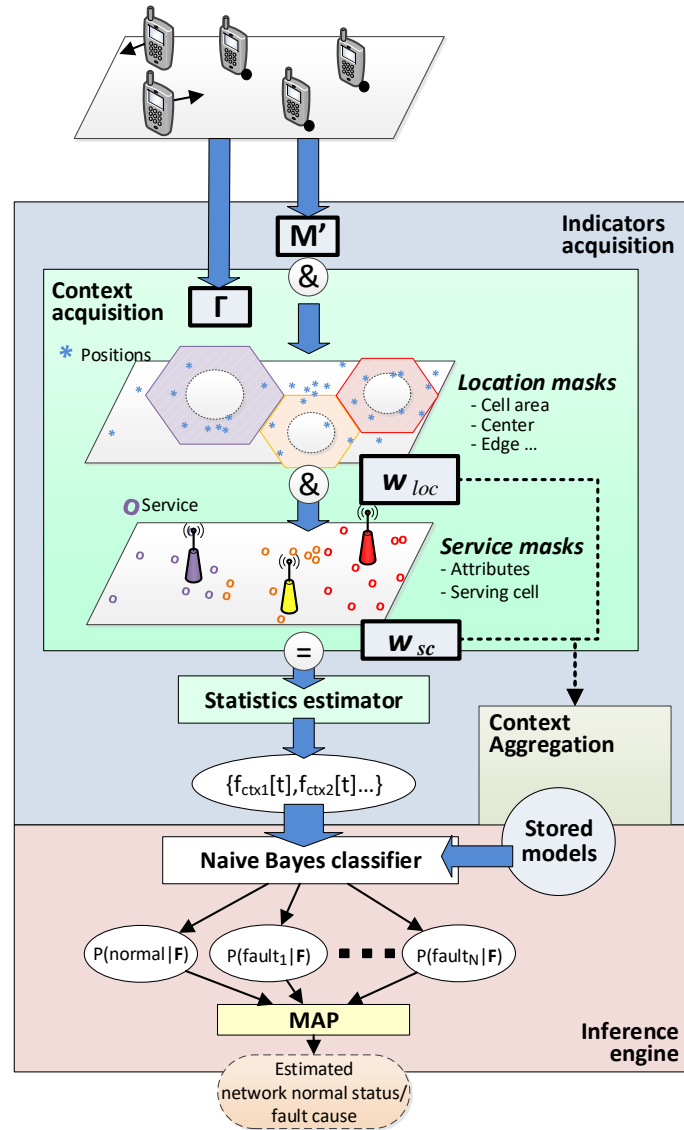

Figure 6.4: Diagnosis data processing scheme.

by different context masks. In the represented scheme, different sets of location masks  $w_{loc}$  and service masks  $w_{sc}$  are applied, which leads to specific values for each contextualized indicator. Based on the correspondent models, the conditional probabilities for each possible network state are calculated.

As inputs for the classifier, the indicators where each state could be more easily distinguishable should be selected. These can be chosen based on the state mod-

els, by selecting those indicators where each model is more clearly differentiated from the rest. If the input indicators are already selected, only those should be computed during the online phase (avoiding the calculation of other context mask combinations).

## 6.4 Implementation considerations

The presented mechanisms involve a series of requirements from an implementation point of view that would highly impact their applicability in real cellular OAM systems. In this respect, the main considerations are at system level, or how the mechanisms can be placed in a real OAM architecture. Also, the available information as well as the computational complexity would highly impact the applicable context masks. This section addresses these issues, presenting some details for the real implementation of the proposed system.

In the proposed approach, the context information (and especially localization) may be obtained from diverse sources. On the availability of the localization information, multiple solutions and systems are commonly present for outdoor UE positioning. At the same time, as presented in Section 3.3.2, indoor localization systems are becoming more extended, with multiple developed mechanisms based on cellular signal analysis and other technologies also applicable for mobile terminals.

As described in Chapter 4, the OAM/SON system could obtain this information directly from the operator network infrastructure (i.e. if cellular based localization is implemented). It can be also obtained from the UEs, by means of management and/or control plane messaging, user application or external servers in over the top solutions.

### 6.4.1 Hybrid and distributed approaches

The implications of distributed and hybrid approaches for self-organizing OAM systems in small cell environments have been analyzed in Chapter 4.

Additionally, indicators based on a unique serving cell are particularly interesting for distributed approaches. Such indicators can be calculated by each cell itself if it has also access to the additional context information (from external sources through Internet or directly coming from the terminal).

This leaves the door open to hybrid implementations of mechanisms based on contextualized indicators. Moreover, pure distributed algorithms could be defined, as it is going to be analyzed for detection in Chapter 7. For example, if a naive

Bayes classifier is used, this can be implemented in a distributed manner. Each cell could calculate the conditional probabilities for their own served-based indicators. Then, these values can be shared between the cells to perform the multiplication required to obtain the final posterior probability of the network state.

### 6.4.2 Classifier inputs selection

For the classifier, its inputs need to be selected. To do so, common approaches make use of human expertise in order to choose those that better reflect network failures [182].

For classical indicators, the options are limited, where the main indicators that can be used are those generated by the faulty cell and its neighbors. When more than one neighboring cell indicator is available, the one more affected by the failure could be chosen as input. In real environments, as the faulty cell is a priori unknown, all indicators would be monitored continuously.

For contextualized indicators, the choices grow exponentially, as multiple definable context masks can be applied, increasing the number of available indicators. However, a set of common location-based indicators can be straightforwardly defined for any environment, as they are clearly affected by different failures. The most useful indicators for each type of failure are presented below:

- *Small cell interference*: This kind of failure would particularly affect measurements gathered at the edge of the victim cell, closer to the interfering one.
- *Macro cell interference*: Such faults would especially affect the served edge of cells located in the border of the indoor location.
- *Power degradation*: In case a cell degrades its transmitted power, the most affected area would be the center of its expected coverage, even if no total coverage hole appears due to the overlapping coverage of other cells. The effects over classic performance indicators could be detected in the long run in dropped calls or excessive overload of neighboring cells. However, the indicated contextualized indicators should help to detect the fault before the service provision is affected.

These indicators can be applied to any deployment. In situations with multiple available indicators for each failure cause, that with the highest deviation with respect to the other network states would be selected. However, an analysis of other context mask options could also lead to the generation and selection of indicators providing even better performance.

### 6.4.3 Mask information sources

As defined in the previous subsection, location-based context masks associated with the center and the edge of a cell should be defined. To do so, different mechanisms can be established depending on the amount of information known on the scenario and the localization data precision:

- *Distance based*: if the distance of the UE to the base station is available or can be calculated, e.g. by means of time-of-arrival. This method is especially applicable for macro scenarios. However, it has been discarded for the analysis because indoor localization methods provide also coordinates, which allows to choose more precise masks.
- *Power diagram based - Voronoi*: Power diagrams are a generalized form of Voronoi tessellations based on the polygonal partition of the scenario considering the Euclidean distance between the base stations and also their transmitted power [187]. This solution allows an estimation of the relative coverage areas and the expected serving cell for each point.
- *Propagation model based*: if enough data is known about the scenario (walls, obstacles and their attenuation), the radio coverage of the cells can be calculated by different propagation models, as in Winner II [188]. Considering shadowing effects may improve the estimated coverage areas. However, such calculations are computationally complex and require a degree of knowledge of the specific scenario that is far from the one that can be expected in real deployments. Also, such models can be highly impacted by changes in the scenario.
- *Measurement campaign based*: Also fingerprint measured information can be used to define the expected coverage area and the center of a cell. However, the need of test campaigns makes this solution not especially applicable if the fingerprinting information was not already obtained for other purposes, e.g. localization [159].

The choice of one or another solution would reside in the available information as well as the complexity of the scenario. In this respect, a power diagram based solution is assumed to be the best option in terms of computational cost and required inputs for open or semi-open areas. Additionally, Voronoi diagrams are very suitable for binary masks, where only the presence inside or outside one area would define the assigned weight 0 or 1. If propagation information is used instead, the same information can be the base to generate more complex weights, for example as functions of the expected received power.

## Border effects

When using a location-based mask, and especially Voronoi based, the defined areas may encompass large zones outside the indoor scenario. This could lead to erroneous aggregation of UEs located outside the premises. Such a problem can be straightforwardly avoided if the indoor location perimeter is known. In such a case, the samples gathered outside the scenario can be weighted or discarded based on their position. Additionally, if weights are assigned to those samples, they can be used to perform analysis on the interference generated in the exterior by the small cells.

To reduce the additional computational cost of applying this perimeter mask, another approach is possible: truncating the Voronoi-based areas by the intersection points with the scenario perimeter. The new calculated areas can then be applied directly during the online phase.

Moreover, other context-based solutions can be also used to discard such samples. For example, conditions related to the unavailability of indoor localization, service that commonly stop working outside the premises, etc.

### 6.4.4 Re-training needs

Re-training is a common challenge of diagnosis mechanisms. For the presented naive Bayes classifier, this would be required to update the probabilistic models of the indicators if the conditions of the network make them obsolete. In this respect, conditions that may impact the validity of the models are:

- *Changes in the fault characteristics*, if the conditions related to the failures change significantly from those existing when learning.
- *Variations in the distribution of the UEs*, if the average user distributions vary significantly.
- *Variations in the scenario topology, obstacles, architecture and cell positions*.

The durability of the probabilistic models would be dependent on the extent and variety of the training set used during the learning phase, as well as the dynamic nature of the scenario. However, these challenges are also common to classical diagnosis mechanisms and have been extensively addressed in literature [189]. Here, the use of the proposed contextualized indicators is not expected to introduce additional requirements with respect to classical solutions. From an operational point of view, the update of the models, if necessary, can be performed in background or during

low-load periods based on previously recorded cases. Therefore, there should not be challenging cost restrictions introduced by such calculations.

### 6.4.5 Computational cost overview

A key point for the application of the presented mechanisms in real time diagnosis is their computational cost and the capabilities of current computing systems to cope with such calculations during online network operation.

One of the main advantages of the presented approach is that the definition of the context mask and the generation of the models are solely performed during the learning phase. Therefore, the computational requirements for the online phase are much reduced.

The online phase is applied once the models and the contextualized indicator values have been already calculated. Its computational cost depends on the number of indicators selected as input for the classifier as well as the number of failures considered by the diagnosis system. Even if real network monitoring systems contain hundreds/thousands of counters and KPIs, the number of indicators used for diagnosis is commonly much lower. For instance, the classifier in [181] made use of 19 indicators, while the system presented in [31] had just three inputs. If the selected indicators are already calculated by the system, the cost of including them in the online phase is low. The addition of one indicator consists in estimating its conditional probabilities and then including it in the product of the other indicators results.

The weight generation would however be the costliest operation in the diagnosis procedure, as it is dependent on the context of each measurement. However, considering that multiple UE indicators would be reported at the same instant (e.g. the UE measurement reports may include both quality and received power measurements), they will also share the same context. Therefore, equal weights may be applied to different measured indicators, reducing the calculation needs. The complexity of the contextualized indicators generation would then be directly dependent on the number of *reports*  $|R|$  gathered during the observation period, where each report is defined as a set of *simultaneous values* received for multiple indicators of one UE, e.g.  $r(ue, \tau) = \{m_1(ue, \tau) \dots m_j(ue, \tau) \dots\}$ . The number of reports in each period would depend on the amount of UEs, the UEs reporting period (how often they send reports) and the length of the observation period.

If the complete diagnosis process is performed at the end of each period (with all the reports gathered in such a period) the computational cost would be therefore related to  $|R|$ . Reducing the observation period would decrease  $|R|$  (assuming fixed

reporting period), but that would also reduce the available time for the calculations assuming a “real time” application of the mechanisms. Reducing the reporting period would also decrease  $|R|$ , but it would impact the level of detail in the analysis. An alternative consists on calculating the weights only when the UE context has changed in a relevant degree. For example, if the UE remains in a similar position its location masks values do not need to be recalculated.

Regarding the cost of calculating each weight, these would depend on their definition. Service weights defined in terms of a certain characteristic of the terminal would be just computed by comparing the context attribute reported with a defined condition (e.g. application equal to a certain one). However, location-based weights calculation would be the most complex and costly procedure to be performed. If the location masks are based on defining if a sample belongs to a certain area (e.g. sample located in the cell edge) it would only be required to compute whether its reported position is inside or outside the defined area. For irregular area shapes, such calculation could be especially costly. However, for the case where areas are defined by Voronoi or following a polygonal form, the complexity of the problem is  $\mathcal{O}(V)$ , where  $V$  is the number of vertexes of the area [190]. An average of 6 vertexes for each Voronoi area in random plane tessellations is estimated [191], a number that could be a good approximation for general cellular deployments (e.g. in the scenario presented in Figure 6.5 the mean is 5 vertexes). In any case, even if multiple simplifications and optimizations could be applied for this process [190], the need of minimizing the number of calculated weights to adjust it to the available resources is key for real-world applications of the system.

## 6.5 Diagnosis evaluation

The presented mechanisms are evaluated in the LTE system-level simulator described in Section A.1, where its parameters were specified in Table A.1. Here the airport scenario also presented in Section A.1 is used. As shown in Figure 6.5 its includes an indoor LTE small cell area with 12 small cells. Three macrocells are placed outside the indoor area.

To provide indoor coverage, twelve LTE small cells are deployed in the building following an approximately uniform distribution. This configuration can be considered as following an unplanned approach, as no planning algorithms were used to define the small cell locations. The closest LTE macrocell is located at 376 meters to the northwest of the scenario.

This scenario is especially representative for the evaluation of the proposed approach as it includes very different types of areas: open and semi-open ones, shops,

corridors and zones full of obstacles and walls. Also, crowded and sparsely populated spots are present. The external base stations, with the closest one located at roughly 500m allows also the study of macrocell interference to the indoor deployment.

In this scenario, different network failures are simulated. Their impact on UE measurements as well as on the indicators at cell level has been evaluated. The evolution of the system and the users has been simulated with a resolution of 100 ms, where the UE distribution and failure conditions change continuously. The observation period for the indicators calculation is one minute.

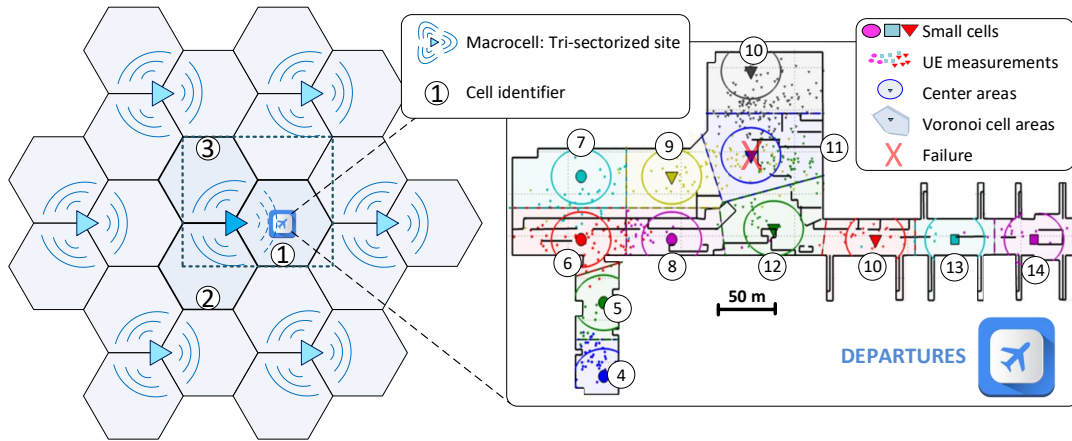

Figure 6.5: Simulated airport scenario.

From the definition of the contextualized indicators multiple options are available for weight definitions, context masks and applications. In this evaluation, different particularizations of the approach would be adopted to provide a glance to the capabilities of the proposed approach.

The evaluation assessment is focused on the analysis of three key common failures in small cell networks related to variations in cell transmitted power, specifically in their *equivalent isotropically radiated power* (EIRP). Such failures are generated following the expression:

$$EIRP_{c_s}^{cell} = EIRP_{Normal}^{cell} + \Delta EIRP_{c_s}, \quad (6.7)$$

where the  $EIRP_{c_s}^{cell}$  of a specific failure case  $c_i$  of a faulty *cell* is equivalent to its normal EIRP value plus a variation  $\Delta EIRP_{c_s}$ . To further test the capabilities of the proposed mechanisms, a certain degree of randomness in this parameter is introduced, varying its value each minute following a uniform distribution  $\Delta EIRP_{c_s} = \mathcal{U}(a_{c_s}, b_{c_s})$  where the minimum  $a_{c_s}$  and maximum  $b_{c_s}$  values depend on

each analyzed network state. Hence, the different failures simulated are:

- *Small cell interference:* due to misconfiguration, the cell transmits above its normal level generating interference to its neighbors. For the simulated scenario, the small cells were originally deployed expecting to transmit at the same power (which is a common approach). Here,  $\Delta EIRP_{SCInterf} = \mathcal{U}(15, 20)$ . Based on commercial small cell characteristics, these values represent a feasible case of EIRP increase, for example, if all the small cells have been configured to transmit at 0 dBm (as in the simulated case), while the misconfigured cell transmits at its maximum power.
- *Macro cell interference:* a signal coming from an external macrocell generates interference inside the indoor scenario, where  $\Delta EIRP_{MacroInterf} = \mathcal{U}(30, 40)$ . This represents realistic values if a previously low powered macrocell starts transmitting at its maximum power. This could also closely reflect the situations where an external repeater or a new macrocell is deployed near the indoor scenario or if relevant structural obstacles (e.g. a building) disappear from its signal propagation path.
- *Cell power degradation:* the cell transmitted power is reduced due to a failure in its RF equipment. It is modeled as a variation in its transmission power of  $\Delta EIRP_{PowerDegr} = \mathcal{U}(-60, -40)$ .

With the inclusion of these randomness margins, the ability of the system to work under different situations and without re-training is also assessed.

### 6.5.1 Learning phase

In the simulated scenario, the terminals report multiple measurable indicators and events, such as handovers, received power and quality levels, etc. For the modeled network failures, different measurable variables have been considered, where the *channel quality indicator* (CQI) [192] is selected as the main source of information about possible channel degradations, as stated in [193]. The CQI provides information on the channel quality experienced by a UE, being directly related to the signal-to-noise-plus-interference ratio of the radio-link.

The CQI has also the advantage of being measured continuously by the terminals, independently of any event. Other counters, such as those based on events (e.g. handovers, drops) are only related to specific events-situations and therefore may not provide continuous information for all positions, being also more vulnerable to the possible scarcity and random distribution of UE reports in indoor scenarios.

As specific statistics for the CQI, the mean and different Xth-percentile distributions were analyzed. The mean was found to be the most suitable CQI statistic, presenting better stability between different measurement periods under the same fault. In comparison, the 5th percentile statistics have shown very disperse values.

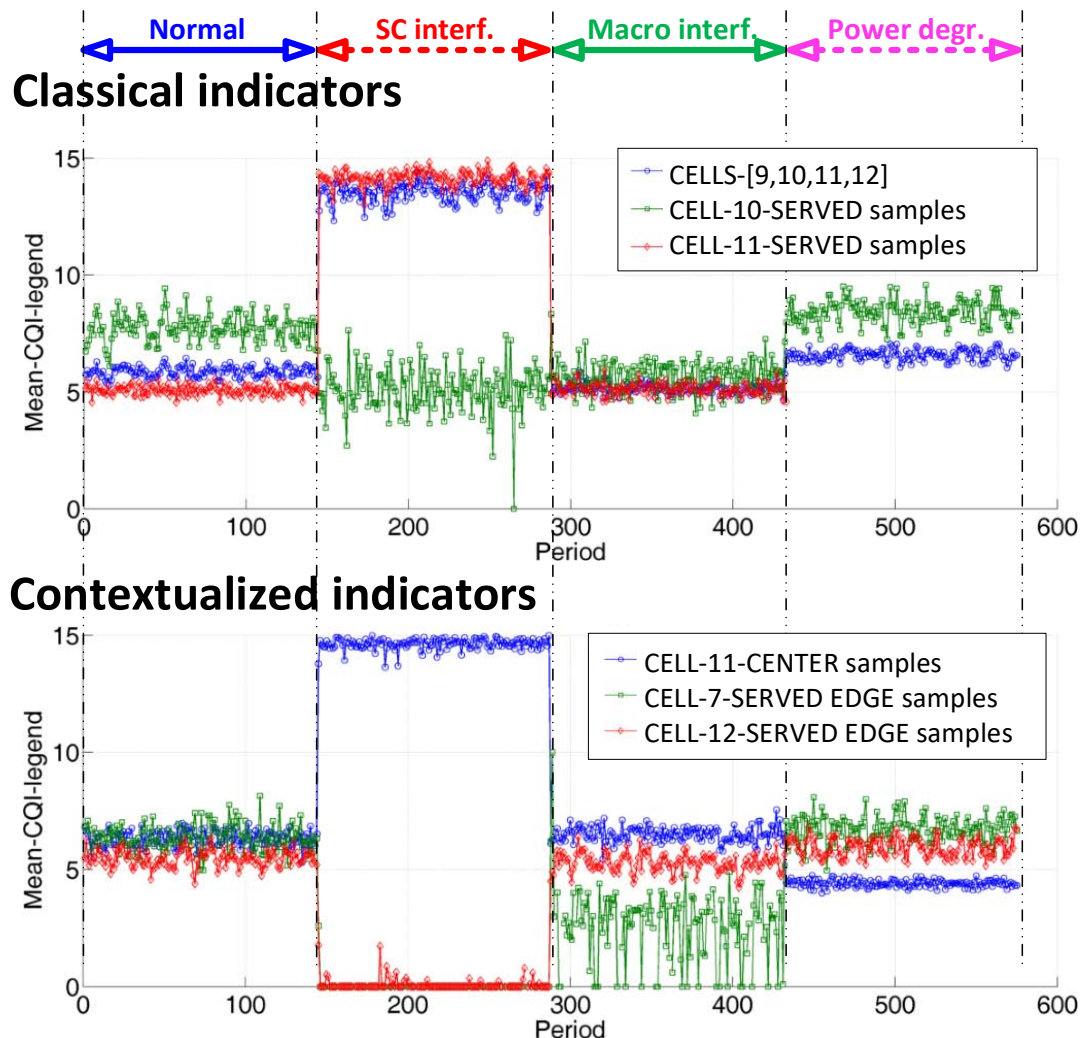

Figure 6.6: Evolution of classic and contextualized CQI indicators.

For the classifiers, three inputs have been chosen for each classical or contextualized approach, following the indications described in Section 6.4.2. For both, the statistical models under each network state (*Normal*, *SC Interference*, *Macro Interference* and *Power degradation*) have been generated. These are based on a training set of 50 periods, being these distributions used to approximate the conditional probabilities for the online phase.

## Classical

The top graph in Figure 6.6 shows the temporal evolution of the main CQI-based indicators when cell 8 is the faulty small cell. A failure in that cell is especially significant, as it is in a semi-open area with also close walls and obstacles.

The indicators are presented for 576 periods of one minute and different network states: normal, macrocell interference, small cell interference and power degradation. Periods when the network is under the same state / fault are placed together as they were simulated contiguously.

The inputs for the online phase have been chosen based on the analysis presented in Section 6.4.2. In this way, the selected CQI non-contextualized indicators are:

- *Cell 11 served samples - CQI*: Mean CQI of the UEs served by the faulty cell.
- *Cell 10 served samples - CQI*: Mean CQI of the UEs served by the cell most affected by the macrocell interference.
- *Cells [9,10,11,12] - CQI*: Mean CQI of the UEs served by the faulty cell and its adjacent neighbors. It is the indicator most impacted by power degradations.

## Contextualized

Given the analyzed issues, UE location information is the main context attribute to be considered for the diagnosis. The cell area is defined as the power-diagram based area of each cell. The cell center is established as the circular area surrounding a specific small cell with a radius of the 75% of the shortest distance between the small cell position and the closest neighboring power-diagram area. The cell edge is defined as the coronal area surrounding a cell formed by its Voronoi area discarding the cell center.

As previously stated, these Voronoi-based areas have the advantage of not requiring any information about the scenario besides the relative location of each small cell with respect to its neighbors and their transmitted power. Also, they allow a faster calculation of a point belonging or not to a specific area. A Voronoi tessellation would acceptably approximate coverage areas in line of sight scenarios with equal transmitted power for all small cells. This approach however may introduce inaccuracies in scenarios including obstacles, walls, etc. For the analyzed scenario, these are considered a good approximation. This can be observed in Figure 6.5, where in the airport scenario, the different plotted UEs are served by the base stations in good correspondence with their Voronoi areas. Except for cell 11, whose

transmitted power is degraded in that situation, the marks and colors associated to the serving cell of the UEs coincide mainly with the tessellation.

The lack of UE measurements cannot be directly associated with a failure as it may be dependent of the real absence of users and/or cell monitoring issues. For these situations, the location masks are a powerful tool for obtaining contextualized indicators for the failure-affected areas, even when the cell is not able to report UE measurements. In this way, edge masks are applied in combination with service masks for the adjacent neighbors. However, the cell center mask for the possible faulty cell is applied without service mask to avoid lack of data in case the faulty cell is too degraded to serve any UE.

The bottom graph in Figure 6.6 shows the temporal evolution of the most important contextualized indicators. Again, those more impacted by each failure are selected. The impact of the power degradation failure can be observed in the *Cell-11-CENTER samples* indicator. Its profile shows a clear reduction in the CQI values, making it the most suitable indicator for identifying the cause. Additionally, the most important served edge indicators are represented. As expected, *Cell-7-SERVED EDGE samples* shows the highest degradation for macro interference. Finally, *Cell-12-SERVED EDGE samples* is assumed to be one of the most affected indicators by the small cell interference generated by its adjacent cell 11.

The advantage of the contextualized indicators over the classic ones can be clearly observed looking at their different distributions. On the one hand, the left side of Figure 6.7 shows the statistical models of the classic indicators described initially. These are represented by the normalized histogram and its approximate Gaussian distribution) calculated based on the training set for different network states. It can be seen how different causes lead to varied differences between the distributions. For instance, small cell interference situations (*SC interf.*) clearly impact the CQI distribution of the UEs served by the faulty cell 11. In fact, a simple threshold (e.g. in CQI=10) could serve to identify if the CQI value corresponds to small cell interference. However, the distributions for the macro interference case (*Macro interf.*) and the power degradation failure (*Power degr.*) present overlapping between them and with the normal state, which would lead to erroneous classifications in the online phase.

On the other hand, the statistical models for the contextualized indicators are represented on the right side of Figure 6.7. Compared to their classical counterparts, the contextualized indicators present a clearer distinction between the modeled network states, which should lead to a better performance in the diagnosis of network failures as it is going to be further analyzed in next subsections.

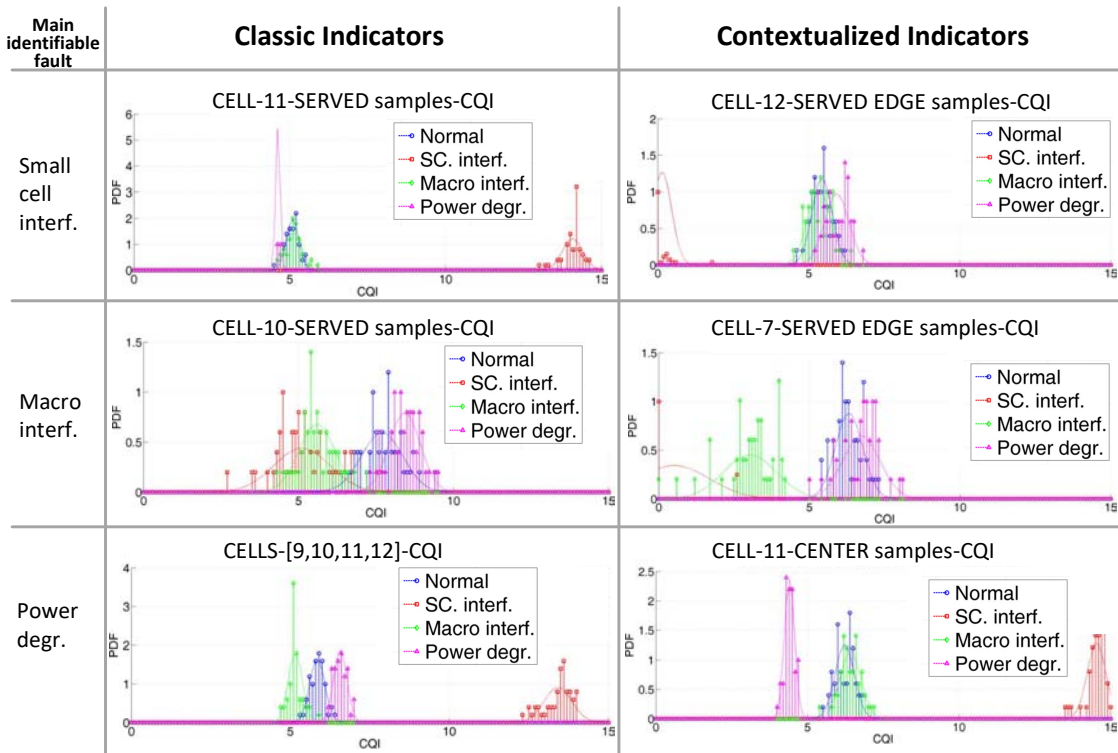

Figure 6.7: Indicators statistical models.

### 6.5.2 Online Phase

The indicators included in Figure 6.7 are selected as inputs for the naive Bayes classifier used in the online phase, for both classic and contextualized indicators.

For the classifier, prior probabilities of each network state must be defined by human experts or by analyzing the occurrence of each cause in previously recorded data. To properly evaluate the capabilities of the proposed mechanisms, prior distributions are considered equal, so the results are not dependent on the quality of the prior probability estimation. The conditional probabilities are calculated based on the Gaussian approximate models generated during the learning phase.

#### Error types

The performance of the diagnosis results is measured in terms of the capability and accuracy for identifying each cell condition by three main figures of merit:

- *Type I error rate* or false positive ratio: the percentage of erroneous positives

obtained for a cause with respect to the total number of periods where the cause is not really present.

- *Type II error rate* or false negative ratio: the percentage of periods where the real cause is not diagnosed over the number of periods where it is present.
- *Inconclusive rate*: defined as the percentage of periods where diagnosis could not be performed. This can be due to the absence of UE measurements meeting the context masks conditions. As presented in Section 6.3.3, the lack of a contextualized indicator input can lead to not providing any diagnosis depending on the technique applied (fallback, no diagnosis or discard indicator).

In terms of data scarcity, in the presented simulation, *CELL-7-SERVED EDGE* indicator (generated by combining the location mask of the cell 7 edge and the service mask of being served by cell 7) is the only one that includes some periods with no samples. In particular, there were 52 periods without values (in a total of 576 simulated periods), where such intervals are coincident with the small cell interference situation and therefore are caused by cell 11 serving the users located in the cell 7 edge due to its increased transmitted power. Thus, the contextualized indicator cannot be calculated in such periods. To address this issue, the three main approaches presented in Section 6.3.3 are applied. Particularizing, the *fallback* technique is implemented using the classic indicator *CELL-10-SERVED SAMPLES* as a substitute of *CELL-7-SERVED EDGE* for periods where the contextualized indicator cannot be calculated.

These approaches are compared with the classic solution, and the results are presented in Figure 6.8 and Table 6.1. The left side of this figure contains the bar graph presenting the type I, type II and inconclusive rates for each network state and the classical and contextualized indicators approaches.

On the one hand, both classic and contextualized indicators diagnosis obtain perfect performance for the small cell interference cause. This is expected from the large statistical deviation generated for such failure in both classical and contextualized indicators.

On the other hand, contextualized indicators greatly improve the accuracy of the diagnosis of the other three network conditions. Their capabilities especially impact the situations where a greater statistical difference is achieved in comparison to the classical approach, e.g. for the diagnosis of the normal status and the power degradation failure. For the normal state, the type I error is reduced very significantly from the 4.43% to the 0.47% (fallback). For the power degradation failure, any contextualized approach achieves zero error in comparison to the 10.49% of the classical case. Additionally, the defined fallback technique provides diagnosis for

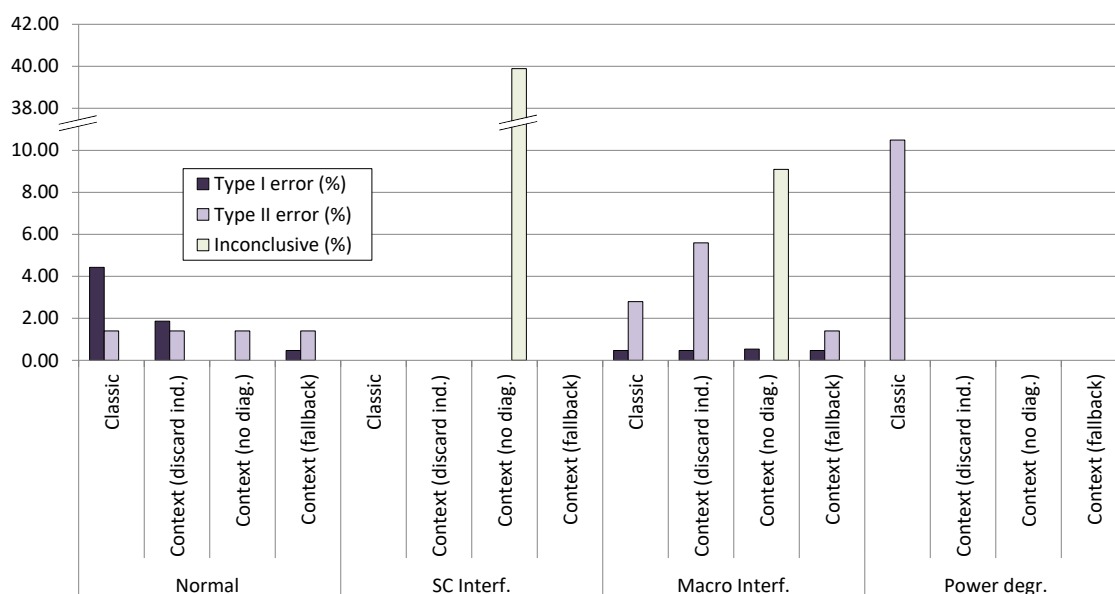

Figure 6.8: Type I / II error and inconclusive rates for the cell 11 case.

Table 6.1: Diagnosis evaluation of each method for the cell 11 case.

Status	Method	Type I (%)	Type II (%)	Inconclusive (%)
Normal	Classic	4.43	1.40	0.00
	Context (discard ind.)	1.86	1.40	0.00
	Context (no diag.)	0.00	1.40	0.00
	Context (fallback)	0.47	1.40	0.00
SC Interf.	Classic	0.00	0.00	0.00
	Context (discard ind.)	0.00	0.00	0.00
	Context (no diag.)	0.00	0.00	39.16
	Context (fallback)	0.00	0.00	0.00
Macro Interf.	Classic	0.47	2.80	0.00
	Context (discard ind.)	0.47	5.59	0.00
	Context (no diag.)	0.54	0.00	9.09
	Context (fallback)	0.47	1.40	0.00
Power degr.	Classic	0.00	10.49	0.00
	Context (discard ind.)	0.00	0.00	0.00
	Context (no diag.)	0.00	0.00	0.00
	Context (fallback)	0.00	0.00	0.00

all periods while only slightly degrading the performance in comparison to the *no diagnosis* solution.

### Diagnosis error and inconclusive rate

To have a summarized view of the network performance, Figure 6.9 shows the total *diagnosis error rate* (DER), measured as the percentage of samples incorrectly classified over the total number of diagnosed periods, independently of the particular cause. The periods where diagnosis is not performed due to lack of data are not included in the ratio. Instead, those periods are represented by the inconclusive rate bar that, as commented, is defined as the percentage of samples where the mechanisms do not classify the network status. Here, it is shown how the context *no diagnosis* is the one providing the best performance, with only a 0.4% of error at the cost of not providing any classification for the 12% of the periods. On the other hand, the fallback approach gives a slightly higher error but still it provides a DER 5 times lower than the one given by the classical indicators.

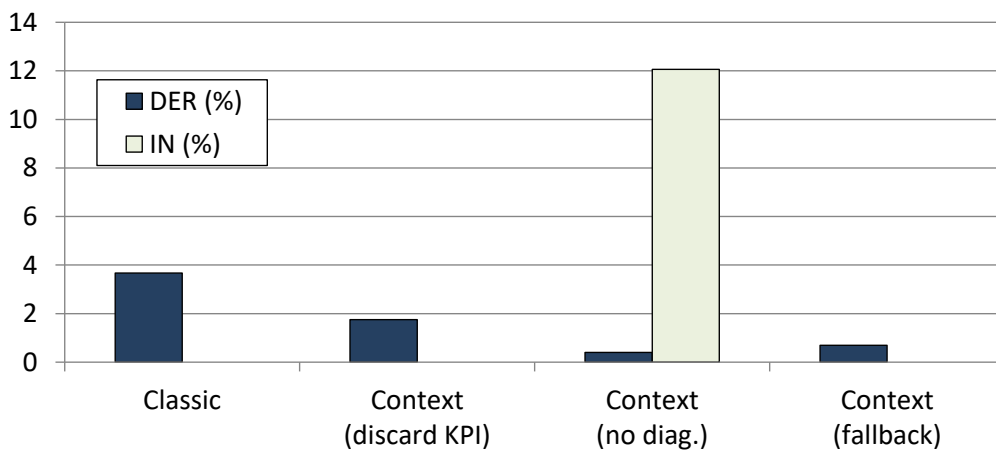

Figure 6.9: Diagnosis error rate and inconclusive rate for cell 11 failure cases.

Finally, the proposed mechanisms are applied to the same scenario and different faulty cells. Specifically, small cell interference and power degradation issues are emulated in cells 7, 8, 9, 10, 11, 12 and 13. For each case, the indicators are particularized for the corresponding faulty cell. For the contextualized approach, the indicators used for diagnosis are the faulty cell center CQI and the adjacent neighbor served edge CQI.

The results are presented in Figure 6.10, where the specific numerical values can be found in Table 6.2. The table includes the DER for the different techniques, as

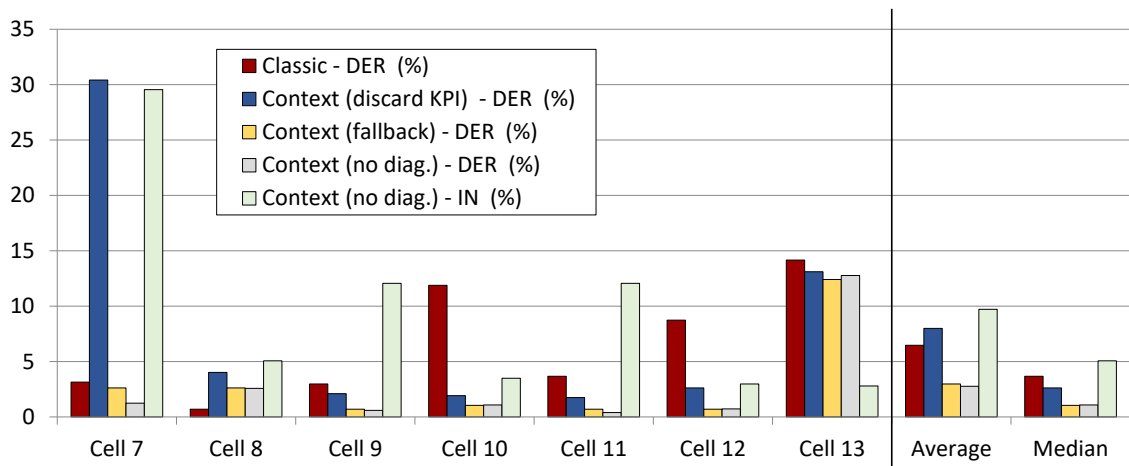

Figure 6.10: Diagnosis error and inconclusive rate for different faulty cells.

well as the inconclusive rate for the *context (no diagnosis)* approach. Here, it is shown how for the main cells of the building, the proposed mechanisms achieved much better performance than the classical approach.

Table 6.2: Diagnosis error and inconclusive rate values for different faulty cells.

Failure cell	Diagnosis error (%)				Inconclusive (%)
	Classic	Context (disc. indicator)	Context (fallback)	Context (no diagnosis)	Context (no diagnosis)
Cell 7	3.15	30.42	2.62	1.24	29.55
Cell 8	0.70	4.02	2.62	2.58	5.07
Cell 9	2.97	2.10	0.70	0.60	12.06
Cell 10	11.89	1.92	1.05	1.09	3.50
Cell 11	3.67	1.75	0.70	0.40	12.06
Cell 12	8.74	2.62	0.70	0.72	2.97
Cell 13	14.16	13.11	12.41	12.77	2.80
<i>Average</i>	6.47	7.99	2.97	2.77	9.72
<i>Median</i>	3.67	2.62	1.05	1.09	5.07

This is especially interesting for the case of cell 10, where a unique adjacent cell is available to support the diagnosis. In this case, the classic mechanism has a very high diagnosis error rate (11.89%) while the contextualized approaches maintain good performance.

For the faulty cell 13 case as well as for cell 8, the contextualized indicators do

not provide a very high advantage over the classical one, being in fact inferior for the cell 8 case. This is given by the specific location of these cells, which makes their small cell interference failure easy to differentiate from the macro interference one: as these faulty cells are isolated from the rest of the network cells, their excessive transmission power does not affect the cell 10 CQI values used for diagnosis in the classical approach. In the implementation of the system, these situations can be automatically detected based on the training data, making use of the classical indicators when the use of contextualized ones is unnecessary.

### 6.5.3 Impact of localization error

An important consideration for the applicability of location based context masks is its robustness to errors in the UE positions. A priori, this would be particularly dependent on the size of the considered areas.

To evaluate this point, errors in the localization sources are modeled in the simulated scenario. To do so, a random error is aggregated to each known position of the UEs before the sample weights are calculated. Such an error is modeled as a normal Gaussian random variable added to the components of the UE position:

$$\left\{ \begin{array}{l} e_x^m = N(\mu, \sigma) \\ e_y^m = N(\mu, \sigma) \end{array} \right. \quad (6.8)$$

where  $e_x^m$  and  $e_y^m$  are the Gaussian error components aggregated to the vertical and horizontal axis coordinates respectively.  $\mu$  equals 0 for all cases while the standard deviation is in the range  $\sigma = \{0, 0.5, 1, 2, 3, 5, 7, 10, 15\}$  meters. This is in accordance to real indoor localization systems, whose error ranges from dozens of centimeters to a few meters depending on the technique and the conditions of the environment [194][195][196].

Figure 6.11 shows the results of the analysis for the faulty cell 11 cases, where the diagnosis error rate of the algorithms is represented given the standard deviation of the introduced location error.

The figure shows how the use of contextualized indicators keeps providing better results than the classical one even for error values as high as 7 meters. The contextualized methods even have half the error of the classical one for a localization inaccuracy of 5 meters, showing a relevant level of resiliency against imprecision in the available UE positions.

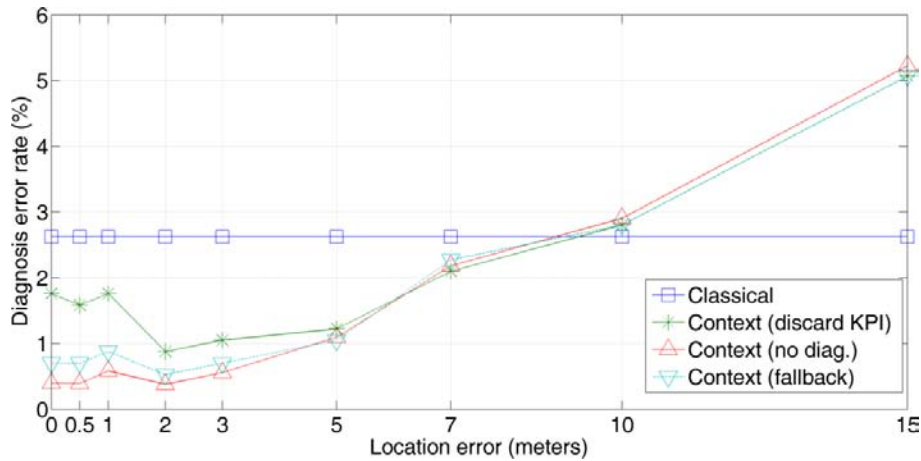

Figure 6.11: Diagnosis error rate given the location error.

## 6.6 Conclusions of the chapter

This chapter has described a novel approach for network self-healing based on the newly defined contextualized indicators. These are constructed combining UE measurements of different radio indicators together with context information, such as the location of the terminal. Based on the novel application of samples weights, contextualized indicators allow a smooth integration in existing diagnosis schemes.

The comprehensive mathematical fundamentals for the proposed approach have been presented: from the application of sample weights to the use of contextualized statistics. Additionally, the concept of context masks has been defined, consisting in sets of sample weights based on different context variables. These masks can be applied to the collected UE measurements to generate distinct contextualized indicators. The implications of implementing the approach in real systems have been also assessed.

The capabilities of such mechanisms have been evaluated with an LTE system-level simulator modeling a small cell network deployment located in a large indoor scenario. The diagnosis of different network failures has been performed based on classical and contextualized indicators. UE context, specifically location and serving cell masks, is used to improve the analysis of the network. The results show a relevant increase in accuracy by the proposed system in comparison with classical approaches. Also, additional analysis on the impact of UE location errors shows the resilience of the approach against high levels of positioning inaccuracy.

Additional applications of the contextualized indicators approach will be presented in Chapter 7.

# Chapter 7

## Distributed approach for sleeping cell analysis

### Content

---

7.1	Motivation . . . . .	134
7.2	Radio information application . . . . .	135
7.2.1	UE radio measurements . . . . .	135
7.2.2	Location-based measurements processing . . . . .	137
7.2.3	Sample weights and AOIs for the detection of sleeping cells . .	140
7.2.4	AOIs calculation approaches . . . . .	141
7.3	Detection algorithm . . . . .	144
7.3.1	Training phase . . . . .	145
7.3.2	Online phase . . . . .	147
7.3.3	Confidence level definition . . . . .	148
7.4	Diagnosis of sleeping cell causes . . . . .	149
7.5	Distributed self-healing . . . . .	150
7.5.1	Procedure . . . . .	151
7.5.2	Implementation . . . . .	154
7.6	Evaluation . . . . .	155
7.6.1	Impact of sleeping cell fault in classic indicators . . . . .	155
7.6.2	RSS indicators and AOIs . . . . .	156
7.6.3	Impact of UE localization error . . . . .	160
7.7	Conclusions of the chapter . . . . .	162

---



After the development of the contextualized indicators as presented in Chapter 6, the adoption of distributed approaches to such as concept was deemed necessary to achieve efficient and resilient implementations, especially for its application for *sleeping cell* failure cases. Considering this, a novel mechanism to detect sleeping cell issues is defined taking advantage of the proposed integration of context-information. In addition, a root cause analysis is developed to determine the cause of the problem. The capabilities of the proposed approach are evaluated in a realistic key simulated scenario, showing the feasibility and usefulness of the proposed approach.

Hence, this chapter is organized as follows: Section 7.2 summarizes the characteristics and assumptions for location-based processing of monitoring information. The proposed mechanisms for detection and cause analysis are detailed in Section 7.3 and Section 7.4, respectively. The combined distributed scheme is then described in Section 7.5 and the defined system is evaluated in Section 7.6.

The work presented in this chapter has been the main target of the following publication of the author:

- S. Fortes, R. Barco, and A. Aguilar-Garcia, “Location-based distributed sleeping cell detection and root cause analysis for 5G ultra-dense networks,” *EURASIP Journal on Wireless Communications and Networking*, vol. 2016, pp. 1–18, June 2016.

## 7.1 Motivation

One of the most common problems in small cell scenarios is the sleeping cell issue, which is the situation where a base station is not able to properly serve users and this is not directly reflected in the OAM monitoring indicators [144]. The causes behind this problem range from BS unplugging, failures in the cell hardware or incorrect configuration. Since many of these failure causes behind the sleeping cell issue could be quickly compensated and/or recovered with automatic actions (like restarting the BS or updating its software), fast mechanisms for failure detection/diagnosis are essential to automatically trigger those tasks. Therefore, detection and diagnosis should, ideally, identify the failure and its causes in the range of minutes/seconds. UE context, and specially, context information can serve as an additional input for troubleshooting of these issues.

This issue has been commonly managed via the centralized analysis of network performance indicators. However, those solutions are unsuitable for the new ultra-dense small cells scenarios that will characterize 5G deployments. Hence, novel approaches are required to cope with the elevated level of cell overlapping as well as

the huge number of sites to be managed.

5G services will also impose very restrict efficiency requirements in terms of response time, signaling costs and computation. Therefore, the adoption of distributed mechanisms is deemed essential to provide the required levels of resilience, independent management and reduced overhead.

For applications other than failure management, few works have looked at the possibilities of distributed small cells coordination. Particularly, references [116][117][118] were dedicated to cooperative resource allocation. In self-healing, the work in [119] proposed a system performing particle filtering for detection of sleeping cells. This is applied in a distributed manner based on UE network measurements. However, on the one hand, this method required the use of large databases of previous cases, also not analyzing the implications of real world implementations of such system. On the other hand, UE context information was not used and the focus of the work was only in the detection of outages.

Therefore, the present work focuses on the description of a novel fully-distributed and automated location-based mechanism for sleeping cell detection and cause diagnosis in ultra-dense scenarios based on the deployment of small cells. Here, the required UE locations are assumed to be provided by external localization sources. The details of the specific method used for UE localization are considered outside the scope of the detection/diagnosis algorithm, making it agnostic to the use of any localization source.

## 7.2 Radio information application

### 7.2.1 UE radio measurements

In the proposed approach UE measurements are established as the main source of information for detection, instead of the classical approach based on centralized data coming from the OAM system. In particular, *received signal strength* (RSS) measurements are chosen as the input for the mechanisms. RSS is defined as the received power level from the base station downlink reference signals. The use of RSS values has multiple advantages over other indicators. Firstly, they are not event oriented, i.e. they can be obtained by the terminal at any time/position, not only in connected mode, but also in idle mode. Secondly, in comparison to signal quality indicators such as the CQI, RSS values are not affected by the variable interference conditions, which are also very dependent on the network load (especially for the LTE case). Thirdly, regarding practical implementation aspects, radio analysis Android apps (e.g. G-NetTrack [197]) provide the RSS measured values, whereas

they do not present quality indicators for most commercial terminals [197]. This is especially important not only from a prototype point of view, but also for the possible over-the-top user level implementations of the proposed system, which could be adopted in some scenarios (e.g. if the monitoring function is combined with a navigation application installed in the smartphones).

Even though the integration between user-level apps and the cellular management plane could be not straightforward, recent works indicate a trend towards an increasingly tighter integration between them. Also, end-to-end analysis and UE-level service-performance measurements are becoming common for network operators [198]. Moreover, the integration of user-level apps with the cellular management plane would become even more achievable if specific apps (such as localization applications based on the cellular signal analysis) or APIs are provided/commercialized by the operators themselves. In this respect, Chapter 4 proposed the interfaces and architecture required to integrate app-level information into the 3GPP management plane. Meanwhile, Chapter 5 presented a real testbed prototype of such UE-level app based network troubleshooting.

Fourthly, RSS-based indicators are defined for any existent RAT and they will also be established for any future 5G standard. For example, as previously presented, in UMTS RSS values correspond to the RSCP while in LTE/LTE-A the equivalent measurement is the RSRP.

RSS values can be sometimes measured concurrently for both the serving and the neighboring cells. However, that is not always the case in live scenarios because the reception of neighboring cells RSS values is conditioned by multiple issues:

- *Incomplete neighbor cell list:* most of the time the UE served by a cell might only report the cells included in the serving neighbor cell list. That list might be incomplete, especially in UMTS. In that technology, the neighbor list is typically manually configured. Also, the serving cell may require to directly receive power from each neighbor to keep it in the list.
- *Unavailability to obtain neighbor cell received power from the monitoring application:* if the application used to obtain the RSS values is a user-level app (e.g. Android or iOS), most commercial terminals only report the values for the serving cell [197].
- *Randomness on the neighboring cell UE reporting period:* even at control and radio-link monitoring level, the neighboring cells are often measured with reduced periodicity or only associated with certain events.

For these reasons, the availability of neighboring cell RSS is not guaranteed.

Therefore, and to develop widely applicable mechanisms, only serving cell RSS values are considered available and used as inputs for the algorithm.

In addition to the UE measurements, it is assumed that UE positions are available to the SON system as part of the information provided by indoor positioning systems. The required architectural coordination of different localization sources with SON mechanisms has been presented in Chapter 4. In this way, UEs positioning information can be obtained indistinctly from the UEs or external sources, such as surveillance camera localization.

## 7.2.2 Location-based measurements processing

In order to support efficient methods for the detection and diagnosis of sleeping cells, the combination of the presented UE RSS measurements with positioning data is proposed. Traditionally, KPIs were calculated based on statistical analysis of UE measurements and events. With that aim, the UE RSS based indicators are computed for each cell by generating statistics of the set of multiple measurements  $M_j[t]$ , captured from a specific set of terminals (e.g. typically those served by a specific  $cell_j$ ) during a particular period of time  $t$ . The calculation is commonly performed periodically, e.g. one KPI value generated every hour based on the measurements gathered during that period.

Conversely, in the location-based proposed method, the individual RSS measurements gathered from the terminals are processed to include UE position information to generate the KPIs. Multiple solutions are possible for the integration of the positioning data with the UE RSS measurements, adapting those previously applied in other fields, especially on image processing, e.g. spatial correlation, pattern-based analysis, etc. For example, Chapter 5 presented a system based on the correlation between each individual UE received levels and the expected values given their position. Such kind of approaches can be valid in femtocell environments where only a few UEs are analyzed. However, the need to pursue fast and computationally low-cost methods where large number of UEs is present leads to the choice of sample weights [185] for the generation of the indicators involved in the diagnosis. Although sample weights are commonly used in fields like social polling, up to our knowledge, it has only been applied in cellular networks for centralized diagnosis Chapter 6, and not for detection.

Using sample weights, the statistical relevance of each sample is strengthened depending on the expected impact of the failure in its measurement spot. Each  $s$ -th RSS value is therefore assigned with a different weight,  $w_{AOI}^{cell_i}(\gamma_{xyz}[s])$ , based on the value of the weight function  $w_{AOI}^{cell_i}(\gamma_{xyz})$  for the position  $\gamma_{xyz}[s]$  where it was

measured.

In the proposed approach, the weight function  $w_{AOI}^{cell_i}(\gamma_{xyz})$  is defined for a certain area of interest  $AOI$  of the analyzed  $cell_i$ , e.g. its expected coverage area.

For any deployment, a set of multiple areas of interest, **AOI** can be established, where  $AOI \in \mathbf{AOI}$ . Each of the AOIs implies a specific  $w_{AOI}^{cell_i}(\gamma_{xyz})$  and therefore different location-based KPIs. These are used as the inputs for the detection of issues in different cells. The specific definition of these AOIs and weights is further analyzed in subsections Section 7.2.3 and Section 7.2.4 respectively.

It must be noticed that previous uses of the term AOI refer to a delimited geographical of a cellular deployment defined by engineers to characterize during a performance study. These often have an extension of several kilometers. In the proposed approach however, the AOIs imply the different areas from where the UE measurements are considered in the statistics calculations used by the sleeping cell detection algorithm, being automatically generated for each small cell, and having a much-reduced size (a few meters).

In the classic non-location-based solutions, two main statistics are commonly applied for OAM purposes: the RSS mean and the RSS 5th percentile. Their classic expressions are therefore adapted in this approach to use of *location-based sample weights*, as described below:

- *Location-based RSS\_mean*,  $\overline{RSS}_{AOI}^{cell_i}(cell_j, t)$ , defined as:

$$\overline{RSS}_{AOI}^{cell_i}(cell_j, t) = \frac{1}{E_W} \sum_{s=1}^{|M_j[t]|} w_{AOI}^{cell_i}(\gamma_{xyz}[s]) m_{RSS}[s], \quad (7.1)$$

where  $M_j[t]$  is the set of RSS values  $m_{RSS}[s]$  measured from the serving cell (or set of cells)  $cell_j$  during the period  $t$  by the UEs located in the  $AOI$  of  $cell_i$ .  $|M_j[t]|$  indicates the number of values in the set.  $w_{AOI}^{cell_i}(\gamma_{xyz}[s])$  represents the individual weight applied to one measurement  $m_{RSS}[s]$ , depending on the coordinates where the sample was measured  $\gamma_{xyz}[s]$ . Finally,  $E_W$  is the sum of all the applied weights,  $E_W = \sum_{s=1}^{|M_j[t]|} w_{AOI}^{cell_i}(\gamma_{xyz}[s])$ .

The serving  $cell_j$  can be equal to  $cell_i$  or a different cell of the scenario. When different, it means that the generated indicator includes information on the UEs served by  $cell_j$  but located in an  $AOI$  of  $cell_i$ , as presented in Figure 7.1. This is one of the main characteristics of the proposed approach, as it allows the monitoring of a possible faulty  $cell_i$  by its neighbors. In this way, the detection of the sleeping cell is done from the measurements obtained from its neighboring cells served UEs.

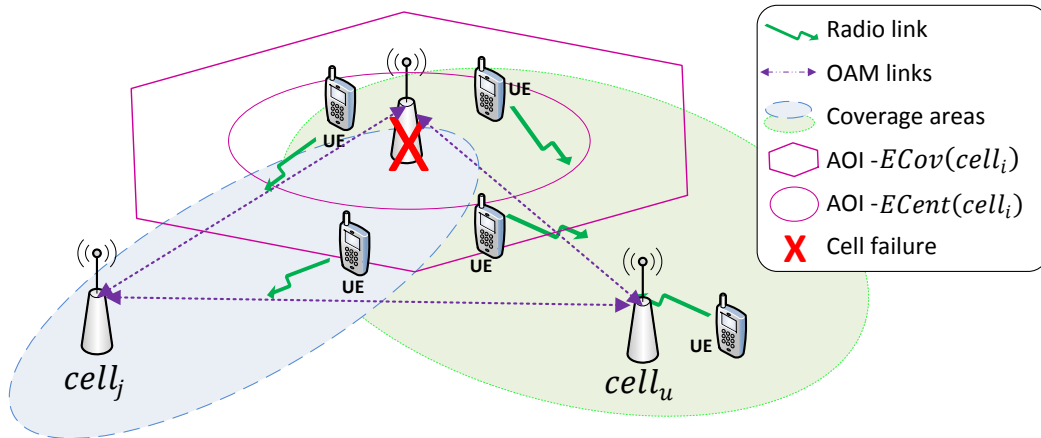

Figure 7.1: AOIs, sample gathering, and connection between cells.

- *Location-based RSS\_5th percentile*, calculated as the RSS value below which the 5% of the lowest collected RSS values are. For non-location approaches, this is a common indicator of the values gathered in the edges and/or at far distance of the cell as well as from low covered (shadow) spots. If a cell is in outage, the classic *RSS\_5th percentile* of their neighboring cells would especially reflect the RSS received by the UEs more poorly served in the area originally covered by the faulty cell.

For the location-based approach and similarly to the *RSS\_mean*, the 5th percentile indicator is based on the  $M_j[t]$  measurements located in a specific *AOI* of  $cell_i$ . To compute it, the common procedure for percentile calculation [199] is adapted to the use of sample weights. In this way,  $M_j[t]$ , the set of RSS samples in a period, is sorted from minimum value to maximum. Then, each sample in the position  $n$  of the ordered list  $M_j^{ord}[t]$  is assigned with the ordinal rank  $r_n$  calculated as:

$$r_n = \frac{100}{E_{|M_j^{ord}[t]|}} E_n - \left( \frac{w_{AOI}^{cell_i}(\gamma_{xyz}^{ord}[n])}{2} \right), \quad (7.2)$$

where  $w_{AOI}^{cell_i}(\gamma_{xyz}^{ord}[n])$  is the weight assigned to the RSS value in the position  $n$  of the ordered list, where  $n \leq |M_j^{ord}[t]| = |M_j[t]|$ .  $E_n$  is the partial sum of all weights applied to the ordered samples 1 to  $n$ ,  $E_n = \sum_{s=1}^n w_{AOI}^{cell_i}(\gamma_{xyz}^{ord}[s])$ .

The 5th percentile would be the sample with  $r_n = 5$ . If no measurement has  $r_n = 5$ , the ordered samples with directly inferior  $r_k$  and directly superior  $r_{k+1}$

nearest rank are selected, in a way that  $r_k < 5 < r_{k+1}$ . The correspondent RSS samples,  $m_{RSS}^{ord}[k]$  and  $m_{RSS}^{ord}[k+1]$  are then used to obtain the 5th percentile by linear interpolation:

$$RSS\_5th_{AOI}^{cell_i}(cell_j, t) = m_{RSS}^{ord}[k] + \frac{5 - r_k}{r_{k+1} - r_k} (m_{RSS}^{ord}[k] - m_{RSS}^{ord}[k+1]), \quad (7.3)$$

### 7.2.3 Sample weights and AOIs for the detection of sleeping cells

In the definition of the AOIs and the sample weights function  $w_{AOI}^{cell_i}(\gamma_{xyz})$  different approaches can be applied to reflect the relevance of each position,  $\gamma_{xyz}$ , in respect to a possible failure in any  $cell_i$ . For the sleeping cell issue, it is expected that the areas most impacted by the possible fault would be those contained in the coverage area of  $cell_i$ , as it would be populated by UEs most affected by its failure.

The AOIs are therefore geographically defined to restrict the samples considered in each location-based indicator. Two different AOIs per cell are envisaged as alternative approaches (with different level of filtering) for the detection of the sleeping cell issue:

- *Expected Coverage area (ECov)* of the possible sleeping cell. The UEs in this area are most likely to be impacted by the cell issue. However, depending on the range of overlapping between cells, this might be compensated by the coverage coming from neighbors BSs.
- *Expected Center area (ECent)* of the cell, referring to locations in the core of the coverage area of a cell. In these, the signal of the cell is clearly predominant in respect to its neighbors. Additionally, to avoid the effect generated by the macrocell and the UEs outside the area of the indoor scenario, only the terminals inside the analyzed indoor scenario (e.g. building) are considered as inside the AOIs.

Additionally, to avoid the effect generated by the macrocell and the UEs outside the area of the indoor scenario, only the terminals inside the analyzed indoor scenario (e.g. building) are considered as inside the AOIs.

Due to the difficulty of obtaining reliable information about the specific height of the terminals and the complexity that would introduce a continuous vertical dimension, coverage areas are commonly defined as multiple two-dimensional layers (e.g. one per building floor). In this way,  $\gamma_{xyz} = (x, y, z = \zeta)$  represents a point in the

two-dimensional Euclidean space  $E^2$  of the analyzed plane/floor  $\zeta$ . Following the same approach, the AOIs are defined as two-dimensional,  $(x, y) \in E^2$ , for each floor of the deployment. These expected coverage areas can be established in terms of signal quality (e.g. CQI-based). However, pure RSS-based definitions are preferred as justified in Section 7.2.1. Based on the expected received power  $\widehat{RSS}((x, y, z), cell_i)$ , the *AOI ECent*( $cell_i$ ) is defined as:

$$ECent(cell_i) = \{(x, y) \in E^2 \mid \widehat{RSS}((x, y, z), cell_i) > \widehat{RSS}((x, y, z), cell_j) + \Delta RSS_{cent}, \forall i \neq j\} \quad (7.4)$$

where  $\Delta RSS_{cent}$  is the additional power (in dB) to be received in the point  $(x, y, z)$  from  $cell_i$  in comparison with any other  $cell_j$ , to consider the point as part of the center of the cell. If  $\Delta RSS_{cent} = 0$ , the expression results in the expected coverage area  $ECov(cell_i)$ .

#### 7.2.4 AOIs calculation approaches

Different approaches can be adopted to define the AOIs by approximating Equation (7.4) for any given  $(x, y, z)$ . Particularly test campaigns, site-specific detailed-scenario propagation models (considering specific obstacles, walls, etc.) or simple log-distance path loss (assuming all points as in line-of sight to the BSs) can be adopted. The application of one or another technique for the *AOI* calculation is dependent on the available information about the scenario. Table 7.1 summarizes the information required for the location-based indicators depending on the approach used for the AOIs estimation. Here, the transmitted cell power can be obtained from the normal configuration/monitoring of the BSs. However, the availability of the rest of the information must be analyzed.

On the one hand, in common situations, test campaigns or detailed scenario models (including obstacles, walls, etc.) are not available, making not possible to apply detailed-scenario propagation models for *AOI* estimation. Additionally, the details of such information can become rapidly obsolete if the scenario changes.

On the other hand, simple log-distance path loss calculation (not considering site-specific walls and obstacles) only require the positions and relative power of the BSs. The knowledge about the BSs positions might be not available if the deployment is unplanned, as it can be especially the case home femtocells. However, the BSs position is typically known for the type of large indoor scenarios (malls, large office, airports) considered. In these environments, BSs (picocells or enterprise femtocells) are mainly installed in fixed positions by professional field engineers, allowing the registry of their locations. For these scenarios, careful planning of the

Table 7.1: Required information depending on the AOI calculation approach.

AOI calculation approach	Required network information	Required localization/scenario information
Classic (no location / AOIs)	UE measurements	-
Test campaign	UE measurements, radiomap database	UE positions, positions during radiomap gathering
Site-specific detailed propagation	UE measurements	UE positions, BSs positions, transmitted power, obstacles, walls, propagation conditions
Simple log-distance path loss	UE measurements	UE positions, BSs positions, transmitted power

deployment is also recommended [27]. Additionally, if the cellular network supports UE positioning, the location of the BSs will be also required for such service.

Although not considering site-specific details can led to inaccuracies, it must be noticed that this assumption is only used to estimate geographical AOIs, not to obtain detailed RSS values. Also, many indoor large scenarios are semi-unobstructed or containing symmetric obstacles (e.g. walls) for the different BSs, minimizing also the importance of a very detailed propagation approach to calculate the AOIs.

Therefore, considering the issues associated with more complex approaches (particularly the lack of the necessary information), simple log-distance path loss would commonly be the most feasible solution to estimate the AOIs in many real deployments scenarios. In this case, for the AOIs definition, a similar reasoning to the one followed in [200] for coverage probability estimation is adopted. For each point  $(x, y, z)$ , the expected received power from  $cell_i$ , value  $\widehat{RSS}((x, y, z), cell_i)$ , consists of the transmitted power of the cell,  $P_{tx}(cell_i)$  minus the path loss to that point  $PL((x, y, z), cell_i)$ . Without including fading effects, the path loss is inversely proportional to the distance between the point and the cell:

$$\widehat{RSS}((x, y, z), cell_i) \sim 10 * \frac{P_{tx}(cell_i)}{d^\alpha((x, y, z), cell_i)} \text{ dB}, \quad (7.5)$$

where  $d((x, y, z), cell_i)$  is the Euclidean distance between  $(x, y, z)$  and the  $cell_i$  BS position. Moreover,  $\alpha$  is the path loss exponent. This exponent has commonly a value close to 2 for line-of-sight propagation in indoor environments (e.g.  $\alpha = 1.87$  for Winner II indoor-indoor A1 model [188]).

Fast-fading effects in the propagation are not included. This is consistent with

their reduced values in the final coverage due to the terminal interleaver and the existent time and power margins for mobility and cell reselection.

If, as expected, the obstacles of the scenario are unknown and the cells transmit roughly in the same band (as it is typically the case), the expression of  $ECov$  based on Equation (7.4) should be approximated as:

$$ECov(cell_i) = \left\{ (x, y) \in E^2 \left| \frac{d((x, y, z), cell_i)}{P_{tx}^{1/\alpha}(cell_i)} < \frac{d((x, y, z), cell_j)}{P_{tx}^{1/\alpha}(cell_j)}, \forall i \neq j \right. \right\} \quad (7.6)$$

This expression is equivalent to a multiplicatively weighted Voronoi tessellation [200]. If all the small cells transmit with the same power, this is equivalent to the classic polygonal Voronoi tessellation:

$$ECov(cell_i) = \{(x, y) \in E^2 | d((x, y, z), cell_i) < d((x, y, z), cell_j), \forall i \neq j\} \quad (7.7)$$

However, if the BSs transmitted powers are not equal, coverage areas might be non-convex, non-polygonal and they can include “holes”. This highly increases the complexity of calculating whether a point belongs or not to the  $AOI$ . To avoid these issues, the work in [200] proposed a circular approximation to the coverage:

$$R_{cov}(cell_i) = \min_{\forall i \neq j} \left( \frac{d(cell_i, cell_j)}{1 + \left( \frac{P_{tx}(cell_j)}{P_{tx}(cell_i)} \right)^{1/\alpha}} \right) \quad (7.8)$$

Following the same approach,  $ECent(cell_i)$  can be calculated as a circle centered in the BS with a radius equivalent to a configurable portion,  $k_R \in [0, 1]$ , of the minimum distance between the BS and the border of its coverage:  $R_{cent}(cell_i) = k_R * R_{cov}(cell_i)$ . In this way, the margin  $\Delta RSS_{cent}$  as defined in Equation (7.4), would be equivalent to:

$$\Delta RSS_{cent} = 10 \log \left( \frac{k_R}{1 + (1 - k_R) \left( \frac{P_{tx}(cell_j)}{P_{tx}(cell_i)} \right)^{1/\alpha}} \right) \text{ dB} \quad (7.9)$$

These expressions allow to compute the AOIs prior to the online detection, storing them with a very reduced cost, whereas they also allow direct  $AOI$  reconfiguration if there are changes in the transmitted power.

For the sample weights, an increasing relevance should be given to those positions better covered by  $cell_i$  and less covered by its neighbors in normal operation. Assuming also a simple approach for their definition, the proposed expression for

the weight is:

$$w_{AOI}^{cell_i}(x, y) = \begin{cases} \frac{P_{tx}(cell_i)/P_{tx}(cell_{dom})}{d((x,y),cell_i)/d((x,y),cell_{dom})^\alpha} & \text{if } (x,y) \text{ inside AOI} \\ 0 & \text{otherwise} \end{cases}, \quad (7.10)$$

where  $cell_{dom}$  is the dominant adjacent cell which highest estimated received power on  $(x, y)$ :

$$cell_{dom} : \left\{ \frac{P_{tx}(cell_{dom})}{d((x, y), cell_{dom})^\alpha} > \frac{P_{tx}(cell_j)}{d((x, y), cell_j)^\alpha} \mid \forall j \neq i, \forall j \neq dom \right\} \quad (7.11)$$

In this way, and with  $ECov$  and  $ECent$  following the same propagation approach, the computation of  $w_{AOI}^{cell_i}(\gamma_{xyz})$  consists in a simple *point-in-polygon* (PIP) [190] and/or point-in-circle calculation.

## 7.3 Detection algorithm

Based on any available indicator  $F$ , typical detection mechanisms are based on calculating which of its samples crosses a predefined detection threshold, considering then that the network is under failure [107]. The presented indicators (RSS\_mean or RSS\_5th percentile, location-based or not) could be straightforwardly used for this process.

This detection approach has important advantages in comparison with more complex mechanisms, like the ones presented in [144], as it allows the immediate detection of degradations based on a unique indicator and in a fast manner. However, it implies the definition of thresholds, typically by human expertise, being each considered indicator associated with a threshold. Thresholds definition is commonly a costly task that implies large times and a deep knowledge of the network behavior that may be not available. Additionally, the thresholds may vary depending on the specific network or BS, complicating their definition.

To avoid this issue, a baseline method based on a naive Bayes classifier is proposed. For its description, upper case letters will refer to variables/indicators, lower case to specific values of such variables and bold letters to vectors of multiple variables or values. As in this case the definition of the variables is simplified in respect to the previous chapter, as the use of set of samples,  $M$ , for its generation have been already established there.

The Bayes classifier method, applied for diagnosis in the previous chapter, is here applied for detection. In its particularization for this case is defined by the following parameters:

- any set of *input indicators*  $\mathbf{F} = \{F_1, F_2, \dots\}$ ,
- their *current values*, e.g.  $\mathbf{f}[t] = \{F_1 = f_1[t], F_2 = f_2[t], \dots\}$ ,
- the *prior probabilities*  $\hat{p}(\mathbf{F} = \mathbf{f}[t] | C_i = c_i)$ ,
- the *posterior probability*  $\hat{p}(C_i = c_i | \mathbf{F} = \mathbf{f}[t])$ ,
- of any *cell*,<sub>*i*</sub>,
- being in a certain *cell status*  $C_i = c_i$ , where  $c_i \in \{Normal_i, Sleeping_i\}$ .

The detection process is composed of two main stages: a *training phase* and an *online phase* that should be performed (in parallel) for any *cell*<sub>*i*</sub> considered for analysis.

### 7.3.1 Training phase

During this initial stage, the conditional pdfs of all  $F \in \mathbf{F}$  indicators given both normal and failure case must be estimated:  $\hat{p}(F | Normal_i)$  and  $\hat{p}(F | Sleeping_i)$ , as well as the prior probabilities,  $\hat{p}(Normal_i)$  and  $\hat{p}(Sleeping_i)$  of the cell status.

The pdfs are calculated from the relative frequency of the values in the training set. Then, the *kernel smoothing* (KS) density approximation [201] is proposed for estimating the pdfs. KS probabilistic model is generated based on the superposition of multiple Gaussian functions. Conversely, it is commonly assumed that RSS-based indicators values can be modeled by a unique Gaussian or Beta distributions. However, this assumption is only correct for uniform users' distributions and non-limited areas of analysis. As it would be shown in the evaluation section, this is not the case for data obtained in more irregular scenarios with complex user mobility. The KS solution is non-parametric and more computationally expensive than other mechanisms. However, this problem can be mitigated for real-time detection as the model is fitted during the training phase and it is already constructed in the online phase. To save storage space, the KS distribution is calculated only in the range of discrete RSS values that can be reported by the UE, which depends on the standard.

Therefore, the stored conditional pdf for each possible status  $c_i$  (normal or sleeping) is a discrete function such as:

$$pdf_{F|c_i}(r_F) = \hat{p}(F|c_i) = \{\hat{p}(r_F|c_i) | \forall r_F \in RG(pdf_F)\}, \quad (7.12)$$

where  $r_F$  is any of the discrete values of the range  $RG(pdf_{F|c_i}(r_F))$  where the distribution is defined. For example, in LTE and considering RSRP values,  $RG(pdf_{F|c_i})$  is equal to the set of integers in the interval  $[0...97]$ , which is a direct mapping of the receive power measurements from -140 dBm to -44 dBm with 1dB resolution [202].

However, during the online phase, the mean or percentile obtained from the set of multiple RSS samples can result in values not included in  $RG(pdf_{F|c_i}(r_F))$ . In that case, KS smoothing, or simpler linear approximation between the immediately lower and higher integer values can be applied depending on the available computational capacity.

One issue for this approach would be obtaining the values for the training set. For the normal status, this is easy to obtain, as the indicator values can be gathered under the normal behavior of the network. For the sleeping cell status, if real fault labeled cases are not available (which is the most common situation), two different options are envisaged:

- *ON/OFF calibration period:* by a simple procedure of disconnecting and connecting the cells in an alternative manner (which can be performed automatically) the system can obtain the needed sleeping cell training set. These may however alter the normal operation of the network.
- *Neighboring cells measurements analysis:* if the terminals can measure and report RSS values from neighboring cells, this information can be used to approximate their expected serving cell values if one cell is disconnected. This process would have the advantage of not disrupting the cell service provision and it could be performed continuously.

Independently of the used method, the validity of the calculated models can be jeopardized by changes in the network: in the BSs positions, in the scenario characteristics, obstacles, etc. In such cases, mechanisms for automatic update of the models shall be applied. Here, reference [203] provided a solution for identifying the need of updating the models as well as online updating. Such mechanisms can be straightforwardly applied to any network indicator, not requiring therefore any modification for the proposed location-based approach.

### 7.3.2 Online phase

This stage is performed in the already working network. Here, the estimated status of  $cell_i$  is calculated by a proposed feature-weighted version of the naive Bayes classifier. The followed concept of weighted naive Bayes classifier was proposed in [204] for general centralized data mining. In the present work however, the applied weights, expressions and application have been completely redefined for its use in cellular distributed failure detection.

In this way, the Bayes classifier is used to combine the values of  $f[t]$ . In this way, for any  $C_i = c_i$  of the two possible status of  $cell_i$ ,  $C_i = Normal_i, Sleeping_i$ ,  $\hat{p}(C_i = c_i | \mathbf{F} = \mathbf{f}[t])$  is estimated as:

$$\hat{p}(C_i = c_i | \mathbf{F} = \mathbf{f}[t]) = \frac{\hat{p}(C_i = c_i) \prod_{\forall F \in \mathbf{F}} \hat{p}(F = f[t] | C_i = c_i)^{\Omega_F[t]}}{\hat{p}(\mathbf{F} = \mathbf{f}[t])}, \quad (7.13)$$

where  $\mathbf{F} = \mathbf{f}[t]$  is the set of current values of the indicators.  $\hat{p}(C_i = c_i)$  is the estimated prior probability of each status value, this means, the total likelihood of the status if no data is known.  $\hat{p}(\mathbf{F} = \mathbf{f}[t])$  is the estimated likelihood of the evidence.  $\hat{p}(F = f[t] | C_i = c_i)$  is the conditional probability for an input indicator value  $\mathbf{F} = \mathbf{f}[t]$  given the status  $c_i$  of  $cell_i$  and calculated as described from the  $pdf_{F|c_i}(r_F)$ .  $\Omega_F[t]$  is the confidence level of the  $f[t]$  value and it is used to modulate the contribution of each value of  $F_{ij}^{AOI}$  in the weighted classifier in each instant.

The consideration of independence between the variables in  $\mathbf{F}$  is disputable, however it is commonly assumed for cellular indicators [29]. Also, naive Bayes classifiers have demonstrated reliable results even when that condition is not fulfilled [186]. Based on this, the estimated status of  $cell_i$ ,  $\hat{c}_i$  is obtained by choosing the status with the highest posterior probability. As only two possible statuses have been defined  $C_i = Normal_i, Sleeping_i$  and being the evidence equal to both, the classifier expression can be simplified to:

$$\frac{\hat{p}(Normal_i)}{\hat{p}(Sleeping_i)} \prod_{\forall F \in \mathbf{F}} \left( \frac{\hat{p}(f[t] | Normal_i)}{\hat{p}(f[t] | Sleeping_i)} \right)^{\Omega_F[t]} < 1 \rightarrow cell_i \text{ is faulty}, \quad (7.14)$$

### 7.3.3 Confidence level definition

$\Omega_F[t]$  is a main parameter to establish the importance of each indicator in the classification. To do so a specific definition of this parameter is established, defined as a function of:

- $|M_F[t]|$ , the *number of samples* used for the calculation of  $f[t]$ .
- $\varphi_F[t]$ , the *weight relevance factor* of those measurements (if  $F$  is a location-based indicator).
- $\Psi(F)$ , the *statistical difference* between the normal and sleeping pdfs of  $F$ .

Firstly,  $|M_F[t]|$  is used to define a minimum number of samples threshold,  $|M|_{th}$ , to consider the indicator significant. Secondly, in the case where  $F$  is a location-based indicator,  $\varphi_F[t]$  is calculated by the normalized sum of the sample weights applied to the RSS measurements, giving higher weight to those  $f[t]$  based on larger number of samples and/or more relevant ones:

$$\varphi_F[t] = \frac{1}{\bar{\varphi}_F[t]} \sum_{s=1}^{|M_F[t]|} w_F(\gamma_{xyz}[s]), \quad (7.15)$$

where  $\bar{\varphi}_F[t]$  represents the normalization factor, being the average of the relevant factors applied in  $t$  to all the indicators in  $F$ .

Thirdly,  $\Psi(F)$  is calculated following the *Hellinger score* [205], serving as a metric of the level of overlapping between the normal and sleeping pdfs of  $F$ . This is where it is applied to the discrete conditional pdfs:

$$\begin{aligned} \Psi(F_{ij}^{AOI}) &= H(\hat{p}(F|Normal_i), \hat{p}(F|Sleeping_i)) \\ &= \frac{1}{\sqrt{2}} \sqrt{\sum_{\forall r_F \in RG(pdf_{F|c_i})} \left( \sqrt{\hat{p}(r_F|Normal_i)} - \sqrt{\hat{p}(r_F|Sleeping_i)} \right)^2} \end{aligned} \quad (7.16)$$

In comparison to other statistical distances (like the Kullback-Leibler divergence proposed in [204]), the Hellinger metric has the advantages of being symmetric ( $H(P, Q) = H(Q, P)$  for any  $Q, P$  distributions) and satisfying the expression  $0 \leq H \leq 1$ , where 0 indicates complete similarity while 1 means complete independence, being a parameter of easy incorporation to any decision algorithm.

With these three parameters, the expression of  $\Omega_F[t]$  is finally defined as:

$$\Omega_F[t] = (|M_F[t]| < |M|_{th}) * \varphi_F[t] * \Psi(F) \quad (7.17)$$

## 7.4 Diagnosis of sleeping cell causes

Once the sleeping cell problem is detected, compensation and recovery mechanisms can be supported by knowledge on the root cause behind the problem. In that respect, Table 7.2 shows the main causes of failures in small cell networks. Here, causes 1, 2 and 3 represent the most common roots for the catatonic sleeping cell problem in small cell networks. 4 and 5 are failures in the OAM system that could lead to the erroneous identification of the cell issue in classic approaches.

While the presented detection mechanism has been centered on UE RSS analysis, other inputs can be used for the assessment of cellular degradations. These come from the analysis of the *network accessibility* (NETACC) of the cellular system elements from the point of view of their non-cellular links: LAN, optical fiber, DSL, etc. This can be checked by centralized SON entities as well as between small cells. An element in charge of that task is named as *NETACC checking entity*. This element or elements can perform the checking periodically or following an event/demand. This check can be performed for a specific small cell element or for the complete deployment backhaul, e.g. by IP-PING style messages. Such information can be modeled as a binary random variable whose value is 1 if the element analyzed is reachable and 0 otherwise.

Combining both the network accessibility indicators and the analysis performed on the UE RSS values it is possible to unequivocally identify each cause. Therefore, simple rules are proposed for the diagnosis of the different cases, as shown in Table 7.2.

Table 7.2: Sleeping small cell causes and network accessibility

Nr.	Failure	Description	Indicator		
			UE RSS values	Small cell NETACC	Backhaul NETACC
1	Small cell booting process	Small cell starting logon procedure into the operator's network fails. The small cell stays active but without transmitting.	<b>Affected</b>	<b>Unaffected</b>	<b>Unaffected</b>
2	Small cell disconnection	Small cell is disconnected from power supply and/or backhaul connection. It stops transmitting.	<b>Affected</b>	<b>Affected</b>	<b>Unaffected</b>
3	Backhaul NETACC	Failure of the backhaul connection of the network.	<b>Affected</b>	<b>Affected</b>	<b>Affected</b>
4	Checking entity NETACC	The entity checking the cells is not able to connect with them.	<b>Unaffected</b>	<b>Affected</b>	<b>Unaffected</b>
5	SON system NETACC	The SON system is unable to connect specifically with the router due to wrong IP config.	<b>Unaffected</b>	<b>Affected</b>	<b>Affected</b>

## 7.5 Distributed self-healing

The implementation of SON mechanisms in current heterogeneous networks brings several issues to the classic centralized approach for OAM in cellular systems. Firstly, one of the main challenges to achieve fast-response failure management in cellular networks is the associated delay and signaling cost of the communications between the central OAM systems and the network elements (UEs, BSs). The network backhaul can be easily overloaded by the signaling costs associated with network monitoring. This is especially the case for femtocells, which make use of non-dedicated consumer-oriented infrastructure. Secondly, the growing number of cells and the complexity of the network might even lead to saturation of the operator's backbone and central OAM elements, as they oversee and operate huge number of network elements.

To avoid these issues, the elements of each deployment should be able to manage themselves. Thus, a distributed scheme is deemed indispensable for the proper performance of the network. In this, the architecture presented in Chapter 6 aims to reduce signaling costs in femtocell deployments by establishing a local OAM element, allowing hybrid algorithms and minimizing backhaul use. Additionally, since the proposed on-site OAM element was only responsible for a local small cell network, the number of cells to be operated by such entity is much reduced, significantly limiting computational costs. While such scheme could be adopted for the mechanisms proposed in the present work, it is still vulnerable to failure in that centralized entity. Also, the small cells may not be part of the same LAN, or their interconnection capacity may be low (e.g. if it is based on WiFi-LAN). Conversely, the use of a fully distributed algorithm would increase the resiliency of the system.

### 7.5.1 Procedure

Given the presented detection and diagnosis mechanisms, a procedure is defined for its distributed application. The proposed approach is based on the collaborative classification of any  $cell_i$  status,  $C_i$  by itself and its neighboring cells. This implies that, for the analysis of possible failures in  $cell_i$ , each  $cell_j \in \mathbf{cells}_i^{imp}$  would be involved in the process, where  $\mathbf{cells}_i^{imp}$  is the set of sites that would be impacted by the possible failure: typically,  $cell_i$  itself and its adjacent ones (as graphically represented in Figure 7.1).

The simplified detection rule presented in Equation (7.14) has as input a set of indicators calculated from the  $\mathbf{cells}_i^{imp}$ . In this scheme, each  $cell_j$  is in charge of computing an indicator  $F_{ij}^{AOI}$ . This is calculated from the measurements  $M_{ij}^{AOI}[t]$ , consisting on those measurements served by  $cell_j$  in a certain AOI (e.g.  $ECov$  or  $ECent$ ) of  $cell_i$ . For example, the RSS\_5th percentile of the UEs served by the  $cell_j$  in  $ECov(cell_i)$ . In this way, the samples are locally gathered and aggregated, minimizing signaling costs.

The complete self-healing distributed procedure is presented from the perspective of any  $cell_j$  participating in the detection of a possible faulty  $cell_i$ .  $cell_j$  will apply the same process for any  $cell_i$  such that  $cell_j \in \mathbf{cells}_i^{imp}$ . In the description of the distinct phases, the expressions and variables already described would be particularized for the distributed case.

#### 1. Definition of $\mathbf{cells}_i^{imp}$ and AOIs

To define the cells likely to be affected by a failure in a particular  $cell_i$ , the approach is to automatically include in  $\mathbf{cells}_i^{imp}$  the  $cell_i$  itself and its adjacent neighbors. The adjacent cells can be defined from the estimated coverage area

maps, selecting the BSs whose coverage areas are in contact.  $\mathbf{cells}_i^{imp}$  set can also be updated based on the neighbor cell list of each cell, as they are automatically updated during network operation [204]. All the cells in the deployment should have knowledge of the different  $\mathbf{cells}_i^{imp}$  sets and their relative position in order to participate in the detection of problems of those sets where they are part of.

Based on  $\mathbf{cells}_i^{imp}$  and their relative positions, the AOIs of  $cell_i$  can be calculated (in a centralized or distributed way) and stored.

## 2. Training phase

As described in Section 7.3,  $cell_j$  participating in the detection of a failure in  $cell_i$  needs to be in possession of the prior likelihood of each status and the conditional pdfs:  $\hat{p}(F_{ij}^{AOI}|Normal_i)$  and  $\hat{p}(F_{ij}^{AOI}|Sleeping_i)$ , where its previously presented nomenclature has been particularized for the indicator  $F_{ij}^{AOI}$ . During the training phase, the pdfs can be constructed and stored directly by  $cell_j$  as  $F_{ij}^{AOI}$  is locally generated by the BS. From these the  $\Psi(F_{ij}^{AOI})$  parameter can be also calculated and stored. The prior likelihoods are assigned with a default or configured value.

## 3. Online phase

During the operational life of the network, the process is divided in different stages of computation and information sharing between the cells.

### 3.1. Individual stage

This stage is described in Figure 7.2. Firstly,  $cell_j$  gathers the RSS samples reported by its served UEs. Secondly, the localization associated with each measurement is obtained directly from localization sources that can be the UEs themselves, a cellular-based positioning system or an external localization service. Thirdly, with this information and the stored AOIs, the values of the  $w_{AOI}^{cell_i}$  are calculated for all the RSS samples and then the location-based indicator value  $F_{ij}^{AOI} = f_{ij}^{AOI}[t]$  is obtained.

Fourthly, based on this and the conditional pdfs, the likelihoods of the current value given the status of  $cell_i$ ,  $\hat{p}(F_{ij}^{AOI} = f_{ij}^{AOI}[t]|Normal)$  and  $\hat{p}(F_{ij}^{AOI} = f_{ij}^{AOI}[t]|Sleeping)$  are calculated as well as  $\varphi_{ij}^{AOI}[t]$  (see Equation (7.16)). Also, the number of samples inside the AOI and used to generate the indicator are propagated to the following distribution stage.

### 3.2. Distribution stage

Afterwards, each cell of  $\mathbf{cells}_i^{imp}$  shares their estimated conditional probabilities with the rest of the cells of the set. This and the next stages are presented in Figure 7.3.

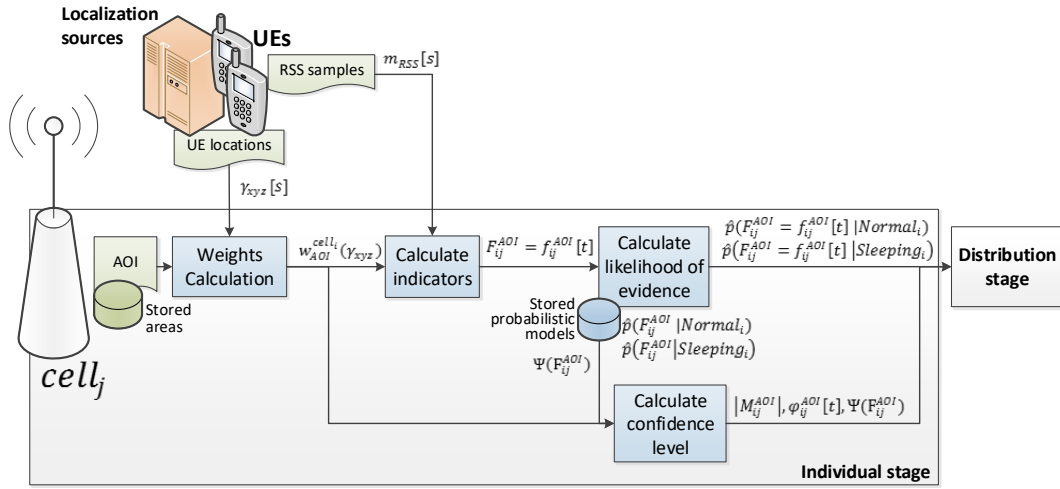

Figure 7.2: Individual stage.

The message from a cell might be not received due to incorrect timing, connection losses or failure in the cell, which cannot be considered a univocal consequence of a sleeping cell failure (as described in Section 7.4). Therefore, the conditional probabilities for the indicator of that cell are assumed 1 for both status, which means that such input is not considered in the classifier.

### 3.3. Computation stage

Having the conditional probabilities from the other cells of  $cells_i^{imp}$ , the status of  $cell_i$  can be calculated by any of them based on the naive Bayes classifier detection rule presented in Equation (7.14), providing its estimated status.

### 3.4. Diagnosis stage

If a neighboring cell is detected as sleeping, any other BS can check its NETACC. This, together with the estimated status, allows to establish the cause behind the failure by means of binary logic following Table 7.2.

### 3.5. Consensus

If the information has been properly received and computed by each BS, the results in terms of the estimated status shall be equivalent to all of them. However, this may not be the case if any distributed message is lost. Also, if the NETACC check provides different results (e.g. due to congestion) for different BSs.

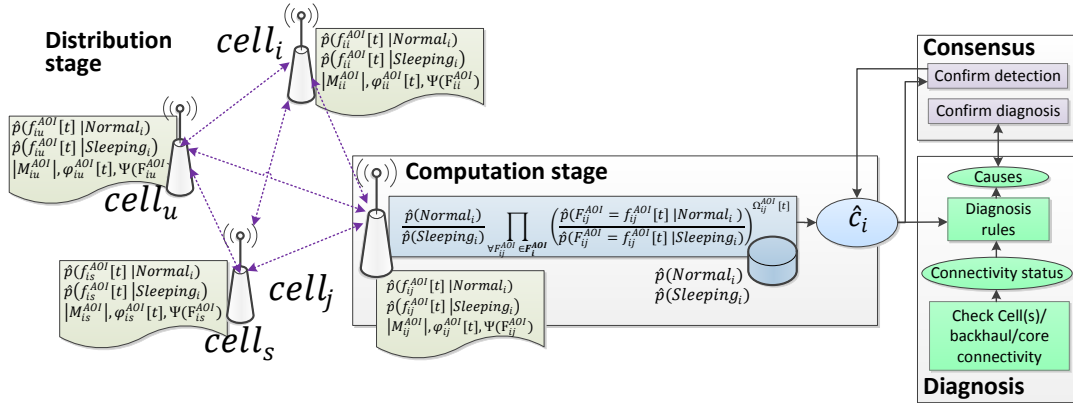

Figure 7.3: Distribution, computation, consensus and diagnosis stages.

Therefore, consensus techniques can be applied for the results achieved by all the BSs. To achieve a common diagnosis from the possible different results of each node, multiple mechanisms have been developed for the general field of distributed computation. For example, the selection of a master/coordinator cell dedicated to perform the final posterior probability calculations and then share them with the other cells can keep consensus as well as reduce the computational costs by freeing some of the BSs from the need of performing the classification [204]. However, the system becomes then more vulnerable to failures in such master cell. To avoid so, the use of strong consistency as presented in [206] is recommended. This is based on making the independent diagnosis performed by each cell consistent by sharing and checking their mutual results.

#### 4. Compensation/recovery activity

Once the cell status is detected and diagnosed, compensation and recovery mechanisms can be triggered. For instance, readjusting cell powers to compensate a neighboring sleeping cell, rebooting automatically themselves if found faulty or alert the operator's OAM system about the issue.

### 7.5.2 Implementation

The proposed distributed system would benefit for the direct interconnection of the cells, preferably by local high-performance connections such as Ethernet LAN. That is the case for femtocell deployments, where the cells are often connected to the

same router and/or access point to the Internet backhaul. There, as proposed in Section 4.2.2 LIPA - SIPTO [177] techniques could be used for over-the-top implementations of the proposed distributed approach. In a more standardized manner, the proposed communications can be integrated through the LTE/LTE-A defined X2 interface between the cells.

The distribution phase could also make use of multicast-type protocols, where the deployed cells can be grouped to reduce the need of addressing the messages to specific BSs.

Moreover, the proposed approach requires a level of synchronization between the cells in order to share the same monitoring and message exchange periods. Such synchronization is already present as part of the coordination between the cellular network elements and the proposed system does not introduce any additional requirement.

## 7.6 Evaluation

For the evaluation of the proposed mechanisms, the system level simulator detailed in Section A.1 was used, where its parameters were specified in Table A.1. Here, the study reflects a numbering of the cells that distinguish picocells from macrocells for the scenario presented in Figure 6.5.

In the simulation, it is assumed that UEs report RSRP values and locations once per second. This is consistent with the signaling constraints of possible over-the-top implementations, whereas control plane solutions may allow higher frequency reporting (as 0.1s considered in [119]).

Catatonic sleeping cells are modeled in the simulation in the following way: for each possible faulty cell 400 continuous monitoring periods of 1 minute are simulated: first 200 periods corresponding to a normal case situation (where the cell works properly), while the following 200 periods model a sleeping cell failure of one BS that stops transmitting. During these periods, the movement of users along the airport is modeled based on random waypoint including realistic user' concentration in security checkpoints and boarding gates areas.

### 7.6.1 Impact of sleeping cell fault in classic indicators

For the presented set-up, Figure 7.4 shows the CBR, this means, the percentage of calls not able to access the cellular network. CBR is commonly used as an indicator of network accessibility and applied on the analysis of possible network failures.

The figure reflects the common case where a sleeping cell failure (in this case,  $cell_{11}$ ) cannot be spotted by purely classical performance indicators.

On the one hand, Figure 7.4-top presents a situation with a high number of average users per cell (around twelve active users simultaneously). In this case, the CBR of the neighboring  $cell_{12}$  highly increases after the failure of  $cell_{11}$ . However, it is observed that there are some peaks of high CBR even in normal status, as well as quite few periods with low CBR under failure condition.

On the other hand, Figure 7.4-bottom presents a situation with a reduced number of users (an average of 7 UEs per cell). For this case, the CBR is not impacted at all by the failure, making impossible its detection based on this metric.

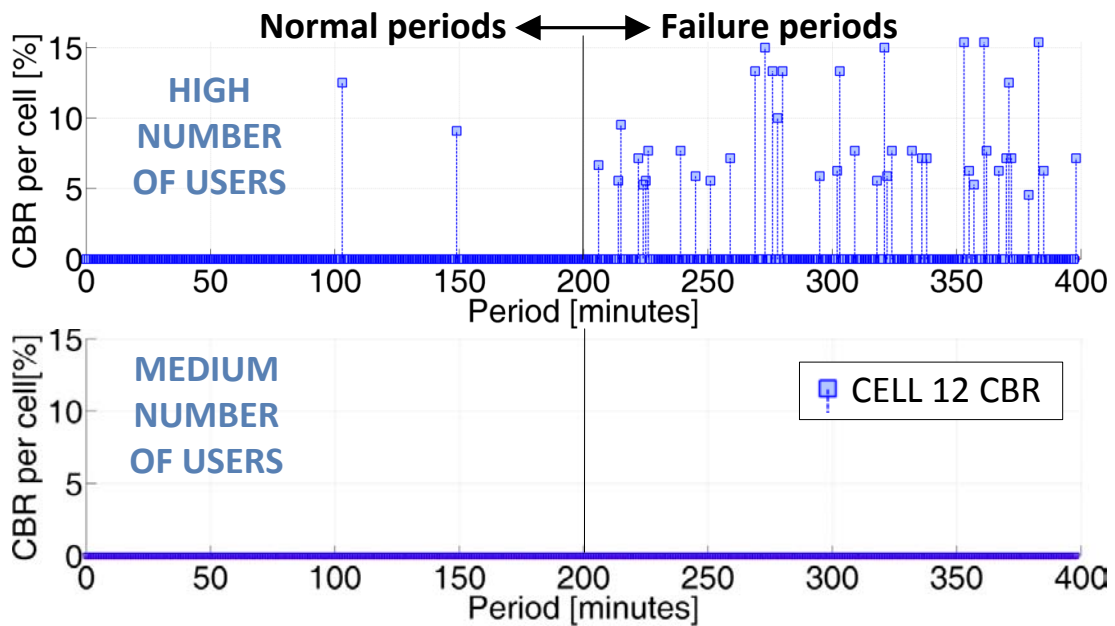

Figure 7.4: Call blocking ratio time evolution for normal and failure periods and different user concentrations.

## 7.6.2 RSS indicators and AOIs

Hereafter, the indicators proposed for the RSS-based detection are assessed with different restrictions in terms of the area selected and the distributed/centralized approach, particularized for the case where  $cell_{11}$  is faulty ( $cells_{11}^{imp} = 9, 10, 11, 12$ ).

Figure 7.5 compares the classic RSS 5th percentile values for the UE served by the cells in  $cells_{11}^{imp}$  with the ones obtained applying  $ECov$  and  $ECent$  (with

$k_R = 0.75$ ) calculated following the simple log-distance propagation approach and the sample weights defined in Equation (7.10) for any serving cell. The results for both  $ECov$  and  $ECent$  are assessed and compared as alternative  $AOI$  definitions, where  $ECent$  represents a far more restricted area than  $ECov$ .

It can be seen how the classic indicator do not show any clear impact due to the failure in most of the loops.

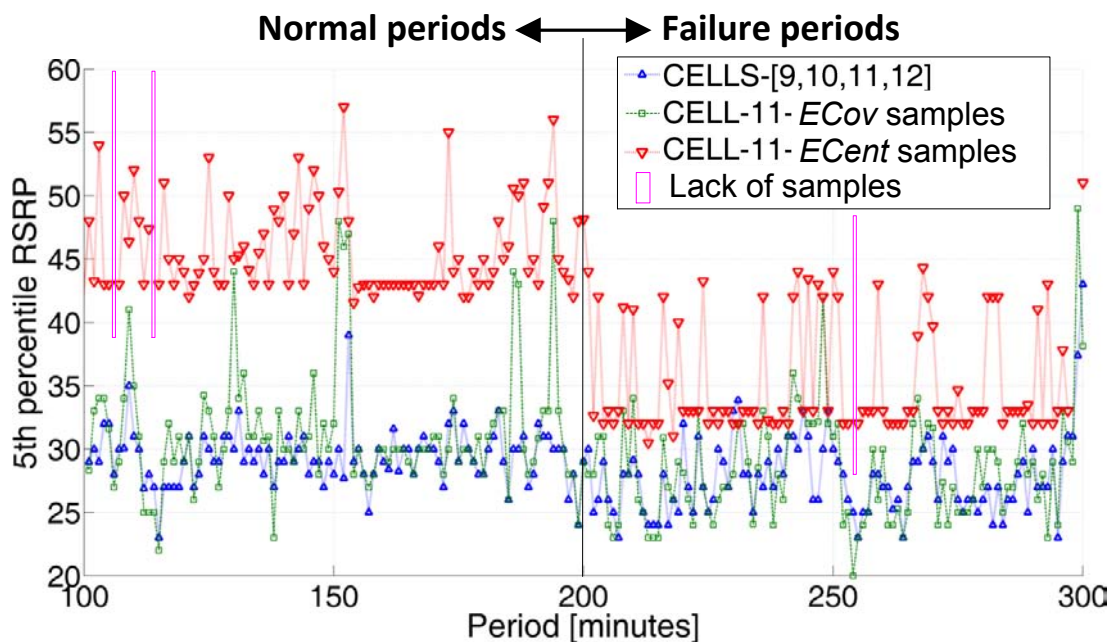

Figure 7.5: Location-based fifth percentile RSRP indicators for different AOIs.

However, the variation is evident for the ones using location  $ECent$  thanks to the selection of the most relevant samples and their weighting. Also, it could be observed how some periods (e.g. 106, 114 and 254) have no values for the  $ECent$  indicator due to the lack of UEs in the area. This indicates how reducing the  $AOI$  increases the visibility of the failure impact but also increments the possibility of not having enough samples to generate the metric.

### Detection performance

The proposed detection Bayes scheme is applied for location and non-location indicators as well as centralized (not filtering the RSS measurements by serving cell) and distributed approaches. In the evaluation, the training phase is performed using as calibration set 50 periods under each cell status, where these periods are considered

as previously labeled. As explained, in real deployments the training set can be obtained from real failure recorded cases, by an operator defined ON/OFF calibration phase or from neighboring cells measurements analysis as indicated in Section 7.5.1.

The conditional pdfs are therefore obtained from this training set. A value of  $|M|_{th} = 10$  is also established. RSS 5th percentile statistics are selected as inputs for the classifier, as they show a higher variation between the normal and sleeping cases than the indicators based on the RSS mean.

The figures of merit that would be calculated for the detection are the *false negative rate* (FN), defined as the percentage of all faulty periods identified as normal; the *false alarm rate* (FA), sometimes also referred in detection problems as false positive, the percentage of the normal periods identified as faulty; and the *inconclusive rate* (IN), or the percentage of periods where there are no UE RSS measurements in the considered *AOI* and no detection is performed.

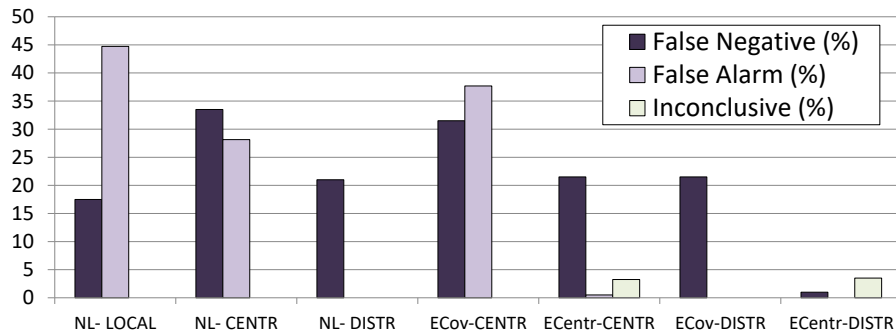

Figure 7.6: FN, FA and IN rates for the cell 11 failure detection.

Figure 7.6 and shows the FA, FN and IN values for the different combinations of detection options and for the case where  $cell_{11}$  is analyzed:

- *Non-location local* (NL-LOCAL) refers to the classic detection performed based uniquely on the 5th percentile of the UE served by the most affected neighbor ( $cell_{12}$  in this case).
- *Non-location centralized* (NL-CENTR) consists in the classic approach of using the 5th percentile of the RSRP values gathered by all UEs served by  $cells_{11}^{imp}$ .
- *Non-location distributed* (NL-DISTR) follows the proposed distribution algorithm but applied over the classic RSRP indicators from the UE served by each cell.
- *ECov and ECent centralized* (ECov-CENTR and ECentr-CENTR) make use

of the proposed location-based approach generating the indicators based on the samples gathered in the AOIs without distinguishing their serving cell.

- *ECov and ECent distributed* (ECov-DISTR and ECentr-DISTR) follow the complete proposed location-based distributed approach presented in Section 7.5.

For non-location based approaches, it can be observed how the use of the distributed approach highly increases the accuracy of the detection, achieving FA=0% with respect to the centralized and local approaches. However, the similarity between the classic RSRP values for both normal a faulty status causes a high false negative rate, FN=21%. The use of localization highly improves this aspect: while the use of *ECov* does not introduce significant improvement in the detection due to its wide area, *ECent* achieves FN=1%, highly outperforming previous approaches.

The study is extended to the rest of the central cells of the scenario {9, 10, 11, 12}, where the failure of each of them is modeled. The resultant detection performances in % are shown in Table 7.3 and Figure 7.7. It is observed how the results of the distributed location-based proposed approach highly outperformed those of the classic mechanisms except for the *cell*<sub>12</sub> case. This low performance is due to the complex wall environment surrounding such station, which makes that even in normal operation, *cell*<sub>11</sub> serves a high number of users in the *ECent* of *cell*<sub>12</sub>. This indicates how more complex definitions of the AOIs (such as those based on the described detailed propagation models) might be required where these situations are present in the deployment.

Table 7.3: Values of the detection performance for different cells.

Cell Indicator type	<i>cell</i> <sub>9</sub>			<i>cell</i> <sub>10</sub>			<i>cell</i> <sub>11</sub>			<i>cell</i> <sub>12</sub>		
	FN	FA	IN	FN	FA	IN	FN	FA	IN	FN	FA	IN
NL-LOCAL	69.0	25.6	0.0	13.5	35.2	0.0	17.5	44.7	0.0	39.5	19.1	0.0
NL-CENTR	46.0	45.7	0.0	19.0	29.1	0.0	33.5	28.1	0.0	48.5	9.5	0.0
NL-DISTR	22.0	0.0	0.0	14.0	0.0	0.0	21.0	0.0	0.0	35.0	0.0	0.0
ECov-CENTR	13.0	15.1	10.5	3.5	0.5	2.8	31.5	37.7	0.0	35.0	21.1	0.0
ECent-CENTR	7.0	0.0	40.1	2.5	0.5	17.8	21.5	0.5	3.3	63.5	0.0	4.3
ECov-DISTR	3.5	0.5	10.8	0.0	0.0	2.8	21.5	0.0	0.0	57.0	0.0	0.8
ECent-DISTR	0.0	0.0	40.6	0.0	0.0	18.0	1.0	0.0	3.5	53.5	0.0	5.0

For the rest of the cells the distributed approaches highly improve the results of their equivalent centralized or local methods. Moreover, the use of location-based indicators provides far better performance than classic ones. Additionally, the use

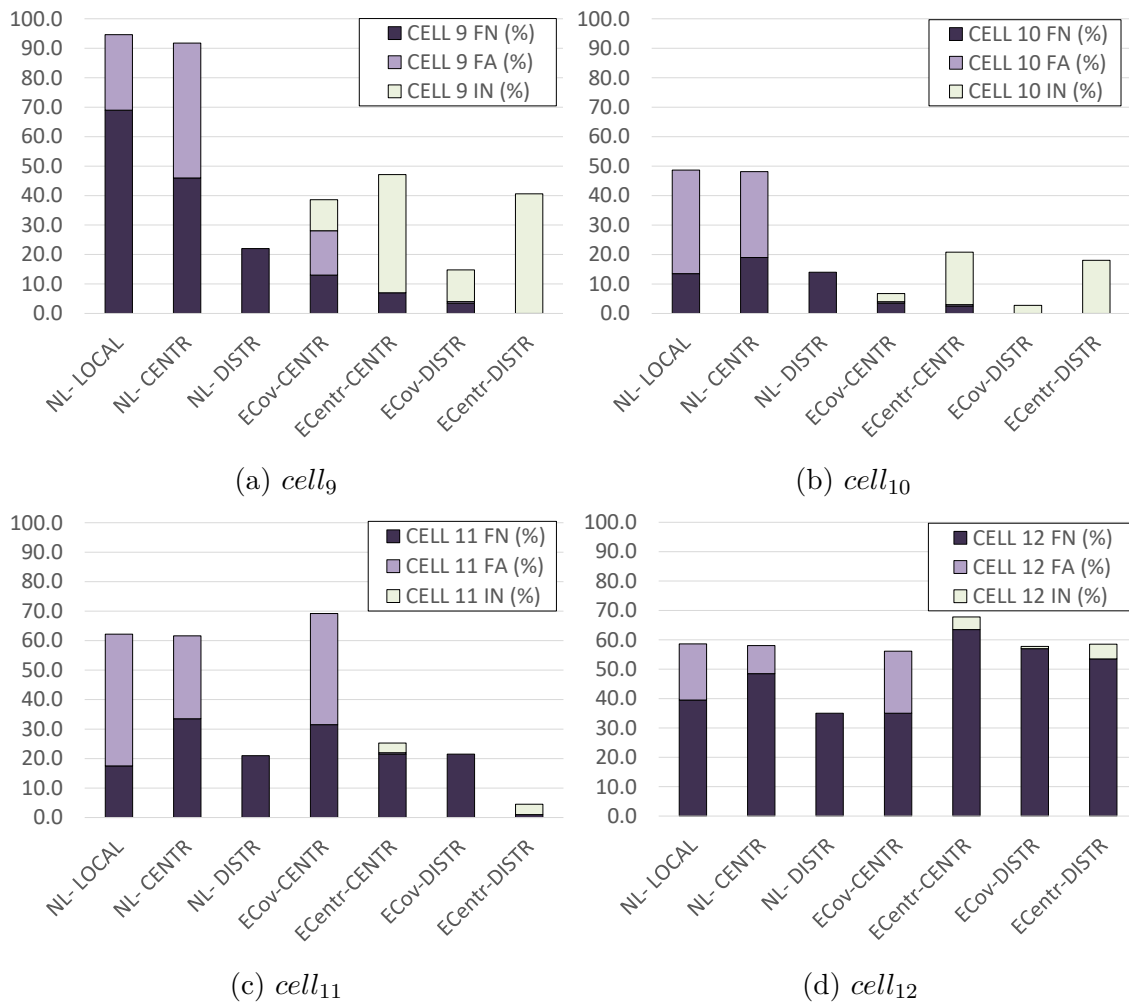

Figure 7.7: Detection performance for different cells in the scenario.

of the narrower *ECent* instead of *ECov*, allows reduced FA and FN at the cost of increasing IN, due to the minor number of available measurements in the AOI.

### 7.6.3 Impact of UE localization error

The previous evaluation demonstrates the capabilities of the location-based approach to improve sleeping cell detection mechanisms. However, one of the main characteristics to consider for its applicability is its robustness to localization inaccuracies. These are modeled in the simulator by an added Zero-mean Gaussian noise to the real location of each terminal before feeding the self-healing algorithms with this data, following the Equation (6.8) presented in Section 6.5.3 for each coordinate,

the error is added as a normal distribution  $N(\mu, \sigma)$ .

The parameters  $\mu$  and  $\sigma$  are respectively the mean and deviation of the normal distribution  $N$ , being consistent to the most common approach for error modeling of positioning methods [207]. In this way, the system is tested for different values of the location error standard deviation  $\sigma = 0, 0.5, 1, 2, 3, 5, 7, 10$ , which is equivalent to the *root mean squared error* (RMSE) of the positioning technique. Such error levels cover from very precise indoor positioning solutions as UWB-based (e.g. reference [208] proposed technique achieves around 1 meter mean accuracy in real experiments) to just an extremely rough estimation, including more common positioning mechanisms as WiFi-based (e.g. the system developed in [166] showed mean errors of 7 meters in real scenarios).

The average results for  $cell_{11}$  given those errors are presented in Figure 7.8 for the *ECent* distributed non-location and location-based techniques. FA is not included in the graph as it is always 0. The figure shows the robustness of the location-based approach even for large inaccuracies, keeping a much better performance than non-location ones even for very high positioning errors as 7 meters.

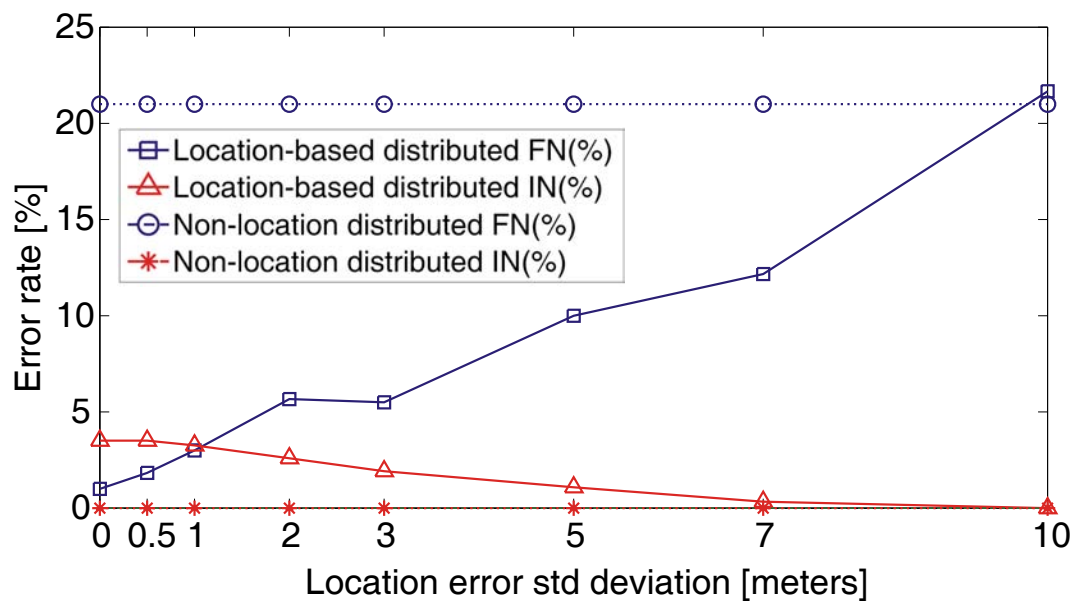

Figure 7.8: Detection performance given different location error values.

## 7.7 Conclusions of the chapter

This work has assessed the use of classic network indicators for sleeping cell failure detection in dense networks, showing the reduced impact that they might reflect. This would commonly lead to delay or wrong detection of network issues based on those indicators.

To overcome this issue, the use of location-supported metrics has been proposed. Such metrics highly increase the capability to detect cell failures. In this way, the proposed location-based indicators support the design of troubleshooting systems with improved failure detection than previous schemes. These have been integrated in a newly defined cell distributed detection and diagnosis algorithm, where the required associated architecture and methodology have been defined.

The proposed system has been assessed with a system level simulator that models a representative DenseNet indoor scenario. The evaluation has shown how the proposed approach highly outperforms the results achieved by classic mechanisms and by centralized implementations. The behavior of the algorithm in the presence of inaccuracies in the localization information has also been analyzed, showing high robustness for the normal levels of inaccuracies found in existing positioning systems.

# Part IV

## Conclusions



UNIVERSIDAD  
DE MÁLAGA

# Chapter 8

## Conclusions

### Content

---

8.1	Main contributions . . . . .	165
8.2	Future work . . . . .	167
8.3	Final remarks . . . . .	168

---

This chapter is dedicated to summarize the main contributions of this thesis (Section 8.1) as well as to present and propose future lines of work (Section 8.2). Finally, Section 8.3 presents the final remarks for the thesis.

### 8.1 Main contributions

This thesis has addressed the task of integrating context information in cellular SON systems, focusing on the small cell indoor deployments. This has covered the analysis of the characteristics of these scenarios, the definition of the necessary architectures to apply context in SON and self-healing systems and the development of specific mechanisms to take advantage of that integration. These have been assessed by simulations and real testbed trials, showing their interest and improved performance in comparison with previous approaches.

In this way, the main contributions of the present work have been:

- **The assessment of the features of dense small cell networks**, identifying the main challenges from the point of view of the application of classic SON and, especially, self-healing mechanisms. It has been evaluated how the



characteristics of these key deployments make the typically applied previous statistical approaches to highly reduce their performance. Conversely, context information is identified as a main input to overcome these challenges. This makes its inclusion as part of the management of the cellular network to be deemed indispensable.

- **A context-aware OAM architecture** for integrating UE context information in cellular SON systems has been therefore developed. This has been defined to allow simultaneous local and centralized SON mechanisms in a coordinated manner. This architecture also supports the inclusion of SON mechanisms at the distinct levels, scopes and entities of the management plane, from the UEs to the general network. The proposed approach has been modeled considering the existing 3GPP architecture while proposing additions to minimize the impact of the introduced context-related signaling in the core network, as well as to reduce the periodicity of the SON mechanisms.
- **A context-aware self-healing framework** has been established to support self-healing mechanisms based on both network data and context information, creating a general approach for those mechanisms. In this framework, different context-based techniques can be defined, allowing the analysis of the network performance considering the individual context of the UEs and other network entities in a comprehensive manner.
- **Contextualized indicators** has been proposed as a novel approach to allow the integration of context-variables and classic performance metrics (e.g. KPIs). Their calculation procedure has been defined based on the use of sample weights generated as a function of any context variable. From this and network performance data, the new contextualized indicators are calculated. In this way, the approach defines the insertion of any context variable, commonly very complex to process, into the generation of time-series in the same form than classic metrics such as counters and KPIs. Thus, the contextualized indicators can then be used as input for pre-existent and newly defined time-series analysis and machine-learning mechanisms, easing their use and adoption in real environments.
- **Novel context-based self-healing mechanisms** have been also defined to tackle different detection and diagnosis use cases. Especially, the proposed contextualized indicators were first applied in the diagnosis of coverage quality issues. Also, a complete system for the detection and diagnosis of sleeping cell problems has been proposed following a distributed approach where the different cells are able to detect and diagnose failures among them without need of any centralized entity. These varied mechanisms have been evaluated

in key scenarios and assessed considering real context sources inaccuracies (particularly UE indoor location systems), showing great improvements in respect to previous approaches.

## 8.2 Future work

From the development of this thesis additional research lines and applications have been identified. These includes both, alternative additions supported by the present work as well as further evolutions and applications of it:

- **Additional context variables and sources:** although most of the presented applications have been based on localization, many other context variables would have a huge importance for OAM and self-healing tasks. Further investigation of other context variables (e.g. end-user applications, preferences...) is expected as those variables can be used to further tune the network for its optimization as well as to identify and characterize failures under different circumstances.

Also, the impact of crowds on the cellular network is currently under study, as well as the necessary mechanisms to predict and incorporate this knowledge into SON algorithms. In this field, the use of social data to predict temporal increases in mobile users' density will be essential, including the analysis of their effects in network performance and use.

- **Inference mechanisms and data analysis:** additional machine learning approaches can be applied to analyze the heterogeneous and complex interactions between context and network-performance variables. Here, the recent advances in the applicability and usability of machine learning mechanisms, deep learning and Big Data process would allow a better understanding and application of the relations between them. It would also support a deeper end-to-end analysis of the massive amount of data generated in current communications networks, allowing to identify specific failure/bottleneck spots and refined characterizations of failures and their compensation at different layers and/or entities.
- **Feature selection and extraction:** the contextualized indicator approach has as consequence the multiplication in the number of available indicators for the troubleshooting process. Also, the use of context implies a huge increase in the variables to be considered. To allow the efficient processing of all this information, mechanisms feature selection, currently under study in the field of

this thesis, would allow the selection of only those statistically valuable for the later SON mechanisms (e.g. the root cause analysis mechanisms). Additionally, feature extraction techniques would allow the combination of the original indicators into fewer derived ones. These new derived indicators are defined to be less redundant and contain more information than the original, increasing the performance and efficiency of later machine learning mechanisms.

- **Trials and testbeds:** by the time of the presented work, the used testbed (as described in Section A.2) was restricted to four UMTS femtocells. Wider trials are expected to be implemented in the close future to extend and apply the developed mechanisms and systems. In this field, newly available UMA LTE testbeds open the way to further testing.
- **5G application:** also by the end of this work, the general 5G features and characteristics are starting to be established by standardization bodies and research projects. As described in Section 2.5 about the perspectives for 5G, increasing opportunities for the application of the developments of this thesis are foreseen. These will be studied in the frame of research projects such as One5G [62], where the research team of the author also participates.
- **Commercial implementations:** some context-based developments derived from this thesis has started to be applied in operational networks, particularly in the diagnosis of network failures. In the search for a more reliable and optimal network, and given the increasing amount and availability of context data, it is expected a growing adoption of context as input for operators' SON mechanisms.

## 8.3 Final remarks

*Research* is, by definition, a never-ending task as its objective is to push forward the boundaries of the human knowledge... just to push again after they have moved a little further.

Although this statement might sound ostentatious, it has a more mundane implication: it is very hard to close and say goodbye to a thesis. Many years of work, analysis, dreams (and occasionally nightmares) and study to be finally expressed in “a few” pages.

With this work the Author only hopes to have contributed a little bit (just an insignificance) in the quest for more efficient and reliable cellular systems and to serve as a supporting step for further advancements in the field.

And without more delay, thank you again, dear Reader, for your time.

Sergio Fortes Rodríguez

Málaga, Spain, 2017.

UNIVERSIDAD  
DE MÁLAGA





UNIVERSIDAD  
DE MÁLAGA

# Appendices



UNIVERSIDAD  
DE MÁLAGA

# Appendix A

## Assessment tools

### Content

---

A.1	LTE system level simulator . . . . .	173
A.1.1	Author’s contributions . . . . .	176
A.2	Indoor femtocell testbed . . . . .	179
A.2.1	Author’s contributions . . . . .	180

---

The techniques developed in this Thesis has been supported by two main tools: an LTE system level simulator and an indoor large-office femtocell real testbed. These two tools are described in the following subsections making a clear distinction of the developments performed during the thesis development by the author.

### A.1 LTE system level simulator

System-level simulators are a key tool for the development of SON mechanisms, since the set of cases available for research on actual networks is scarce, both for the research community and, quite often, for the operators themselves. This is specially the case for self-healing and the need for failure data. The availability of information about real-network problems is limited to the random occurrence of the failures themselves, and the collected data are often not properly labeled or stored for future reference.

Taking this into account, the present thesis was supported for the already developed LTE system level simulator presented in [209] and [41]. This simulator was implemented as part of the previous work performed by the MOBILENET team



and is extensively used for the development and evaluation of the SON algorithms researched by the group.

Developed in Matlab and fully configurable, the parameters of the simulator are summarized in Table A.1. The radio environment uses the Winner II propagation model [188], where fast-fading is modeled by the Extended Indoor A model [210]. The UEs pedestrian-style movement is simulated by a random waypoint based model, incorporating also the possibility to define user distribution concentrations (hotspots) in key areas. Mobility hotspots are simulated following the approach presented in [211], allowing a pre-defined and heterogeneous distribution of the destination points and probability density function of the pause time for each individual node. Wrap-around technique is used to avoid border effects in the simulation. The RRM model also allow multiple options in terms of cell reselection, *directed retry* (DR) and scheduling: *best channel* (BC), *round-robin - best channel* (RR-BC), large delay first to best channel (LDF-BC) or *proportional fair* (PF). For a detailed description of the different RRM options and the rest of the simulator parameters please see [209].

Each execution of the tool runs through consecutive iterations of the simulated network. During each simulation loop or *time span* (configurable from seconds to hours) the UEs move in the scenario, generate traffic demand and are assigned with radio resources (scheduling) and the performance of the network is monitored. All this is performed with a specific *time resolution* (fixed as 100ms). Once a loop ends, the monitored parameters of the network are used as inputs to the SON mechanisms as presented in Figure A.1. These mechanisms can then analyze/identify the status of the network, generate configuration changes / *actions* in the network (e.g. BS transmitted power change) that will affect the subsequent loop.

In this simulator, different scenarios comprising both macro and small cells can be implemented, defining them by the number and distributions of its BSs (both small and macrocell), walls and floors. Through time, multiple environments have been modeled, including an office building (as described in [41] and shown in Figure 4.7) and one of the UPM premises, as shown in [159].

For the present study and the evaluation of the proposed algorithms, a new scenario emulating the departure area of the Málaga city Airport, IATA code: AGP (ranked in 2014 and 2015 as the 35th busiest airport in Europe with fourteen and a half million passengers per year [212]) was implemented (see Figure A.2). This scenario represents a key LTE small cell dense deployment in a large indoor area comprising 200x300 meters, with an irregular building plan including boarding gates, security checks and passing boarding bridges. Simulated users move in this structure, where realistic user pattern concentrations were defined in the security check area, boarding gates, etc. To provide indoor coverage, twelve LTE small cells are located

Table A.1: System level simulator parameters

Parameter	Detail	Value
Propagation model	Indoor-indoor	Winner II A1
	Indoor-outdoor	Winner II A2
	Outdoor-outdoor	Winner II C2
	Outdoor-indoor	Winner II C4
BS model	Directivity	Omni (small) / tri-sector (macro)
	Access	Open (small) / open (macro)
	EIRP	Max. 13 dBm (small cells) / 43 dBm (macro)
UE model	Noise figure	9 dB
	Noise density	-174dBm/Hz
Traffic model	Calls	Poisson (avg. 0.43 calls/user*h)
	Duration	Exponential (avg. 100 sec)
Mobility model	Outdoor	3km/h, random direction & wrap-around
	Indoor	Random Waypoint based model
Service model	Voice over IP	16 kbps
	Full Buffer	
RRM model	Bandwidth	1.4 MHz (6 PRBs)
	Access control	Directed Retry (Threshold=-44dBm)
	Cell reselection	Criteria S, R
	Handover	Events A3, A5
	Scheduler	Voice: BC, RR-BC, LDF-BC or PF Full buffer: BC, RR-BC, LDF-BC or PF
Time resolution		100 ms
Algorithms	Time span	Configurable

in the building following an approximately uniform distribution. This configuration can be considered as following an unplanned approach, as no planning algorithms were used to define the small cell locations. This indoor location is placed in a large external area (3x2.6 km<sup>2</sup>), where three macrocells are also placed, being the closest one located at roughly 500 meters to the northwest of the airport indoor area.

This and the other scenarios in the simulator corresponds to the kind of small cell deployments currently under deployment, as the ones presented in [213]. Also, they are consistent with the models of environments expected in 5G indoor hotspot scenarios [68].

### A.1.1 Author's contributions

As previously indicated, the simulator was already developed by the start of the present thesis, where the complete emulation of the propagation model, radio environment and scheduling was already included in the system. Therefore, for most of these technical aspects the author acted as an end-user of the tool.

However, encompassed in the 5th objective of this thesis (as described in the Section 1.3 presented in Figure 1.1), the need for modeling and testing new context sources, SON algorithms, and in particular, self-healing techniques lead to different additions to the simulator. These extensions are represented by Figure A.1, which marks the different functionalities emulated by the simulator.

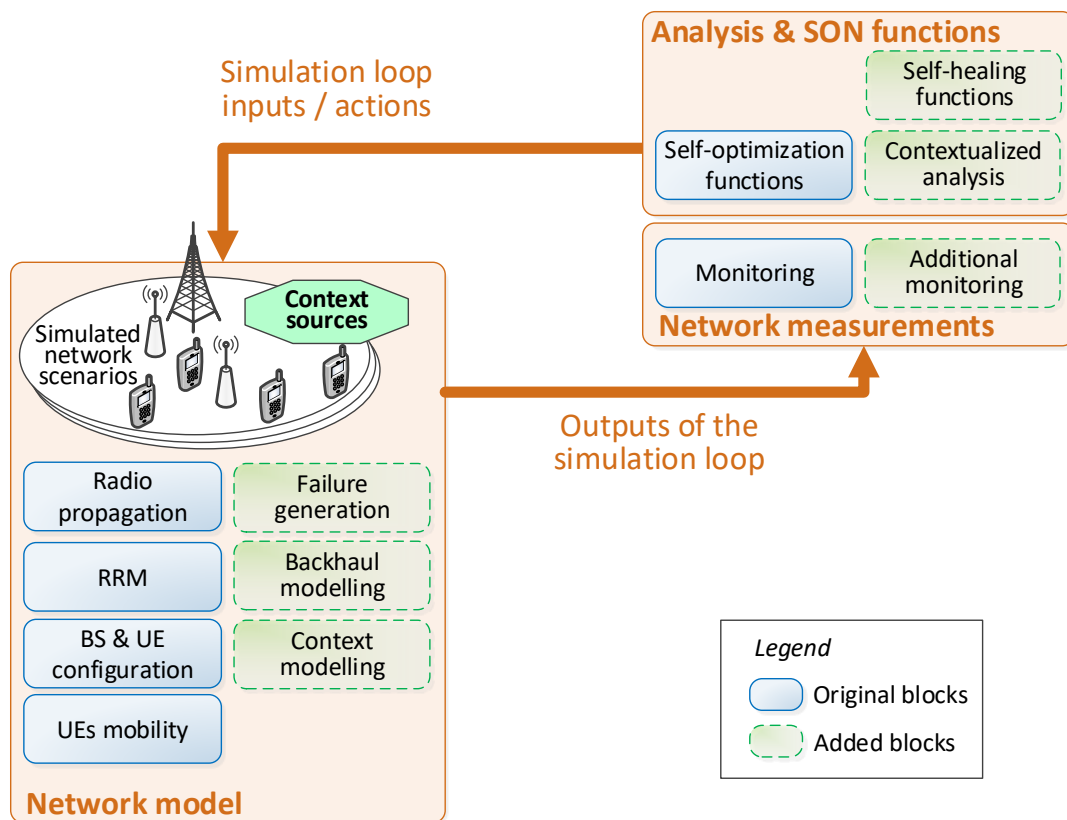

Figure A.1: Scheme of the LTE system-level simulator functionalities.

In the simulator, the author developed the addition of the following new functionalities:

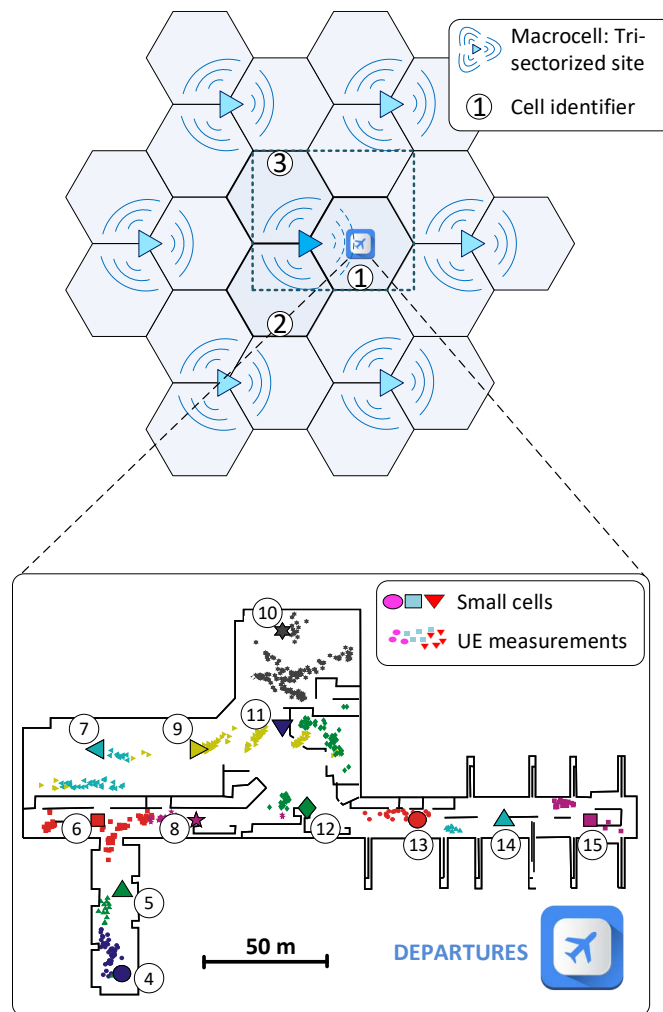

Figure A.2: Simulated airport scenario.

- **New scenarios:** additional environments were added to the already implemented macrocell and enterprise building ones described respectively in [83] and [178]. Particularly, the Málaga city airport scenario presented in this section was included as key for the assessment of SON mechanisms in dense environments.
- **Failure generation:** the emulation of network failures was not originally included in the simulator. The different faults considered through the thesis (and to be presented in further chapters) were integrated in the system, including power degradation, small cell interference, macrocell interference, BS power miss-configuration, system and catatonic sleeping cell.

- **Backhaul modeling:** to include the connection of the BSs with the core network a simple model of the backhaul was added to further characterize different failures. In this way, it was possible to model issues associated with the lack of connection by the different elements, the absence of monitoring information even if the cell is properly working and complete BSs network disconnections. This was applied mainly in the characterization of diverse types of sleeping cell causes and its relationship with the accessibility of the different network entities as it will be presented in Section 7.4.
- **UE individual analysis and context modeling:** the monitoring in the simulator was originally based on the classic OAM analysis where the performance was measured in terms of general metrics calculated as statistics between all the terminals served by a specific BS. To assess and develop a context-aware approach, the capability of monitoring individual UE indicators was added. Also, the behavior of context variables, such as positioning sources, was implemented. The application of individual monitoring of UEs' historical record was included, as well as the possibility of grouping any set of terminals for their statistical calculation. Also, the analysis of the UEs' position of the UEs was included, also modeling the expected inaccuracies that any positioning source would have, as it will be described in Section 6.5.3 and Section 7.6.3.
- **Additional statistical and graphical assessment:** in order to fully address the status of the network, additional functions for the representation of the UEs in the scenario were included (as in Figure A.2), as well as to reflect the coverage areas, the statistical distributions of the UE measurements (e.g. as in Figure 6.7) and the applied *context masks* as they will be described in chapters 6 and 7.
- **SON functions:** the algorithms performing the self-optimizing and self-healing mechanisms, as they will be described in further chapters, were also implemented in the simulator. On the one hand, this included the tuning and re-definition of previous implemented systems, such as fuzzy network controllers (see Section 4.4). On the other hand, it also implied the development and implementation of non-previously defined or deployed mechanisms, such as the statistical profiling, *contextualized indicators* and Bayesian classifiers that will be described in further chapters, as well as the methods for the performance evaluation of the implemented mechanisms.

## A.2 Indoor femtocell testbed

As part of the MONOLOC project, an indoor cellular testbed network was implemented to provide a real-world trial for both SON function and cellular-based UE indoor positioning. The cellular network itself consists of four femtocells located in a real large office area (55x25 meters), as presented Figure A.3. Given the non-availability of LTE equipment and frequencies by the time of the tests, UMTS femtocells were used. In particular, the model 9361 Home Cell of Alcatel-Lucent [214]. Although the algorithms developed for this thesis are in general defined for LTE, the equivalent UMTS values are considered when working with the femtocells. Additionally, around the building, there are different macrocells of the same operator from which there are no direct control, but that the UEs could connect to. The summary of the characteristics of the femtocell testbed are presented in Table A.2.

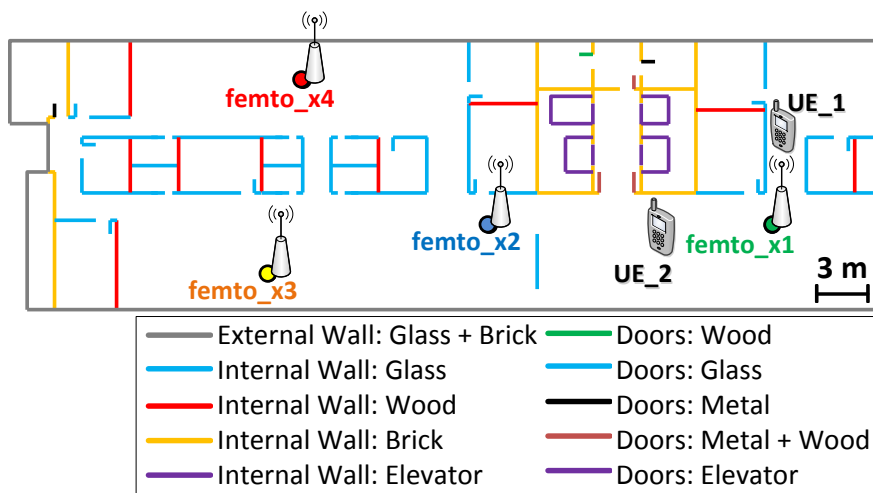

Figure A.3: Testbed scenario.

In this environment, the reports from the terminal are based on a proprietary Android app developed by UC3M [215], while in final implementations it can also be based on 3GPP standard control plane messages [183]. The connection between the UEs and the external entities and servers is performed through a *Java Message Service* (JMS) system Figure A.4. These external entities include:

- **Localization system:** in charge of estimating the UEs position based on cellular based fingerprinting.
- **End-user applications server:** to provide navigational services to the UEs.

Table A.2: Testbed elements and parameters.

Parameter	Detail	Value
BSs	Model	4 x Alcatel-Lucent BSR 9361 Home Cell
	Firmware	2.4.1
	Directivity	Omni (small) / tri-sector (macro)
	Access	Close (small) / open (macro)
	EIRP	<i>Configurable</i> : 13 dBm (femtocells typ.)
	Backhaul	Ethernet (3 femtocells) and WiFi LAN (1 femtocell)
UEs	Hardware model	HTC Desire S S510e
	Operative system	Android 2.3.5
	Reporting	Proprietary UC3M app: <i>BTSFingerprint</i> [215]
Elements comms.	Internet	JMS
Reporting time		Variable, 1 report/s typ.
Algorithms	Time span	Variable

- **Femtocell configuration tools:** through which the femtocells parameters can be changed.
- **SON system:** in charge of implementing SON functions, making use of the UE context and monitoring information coming from the rest of the entities of the testbed. From these, it generates configuration changes for the femtocells and provide information about the status of the network (e.g. detecting femtocell failures) to the localization system so it can readjust its algorithms accordingly [7].

The communication between these elements is based on *JavaScript Object Notation* (JSON) messages directed through different queues JMS system.

### A.2.1 Author's contributions

The author participated in the Matlab development of the general SON system interaction with the rest of the testbed elements, including also the definition and interaction based on JSON messages. Figure A.5 shows the SON system *graphic user interface* (GUI) that serves to monitor the status of the network, the position of the terminals (as provided by the UPM positioning system) and the behavior of the SON mechanisms. It was also in charge of the implementation of the self-healing mechanisms of the system.

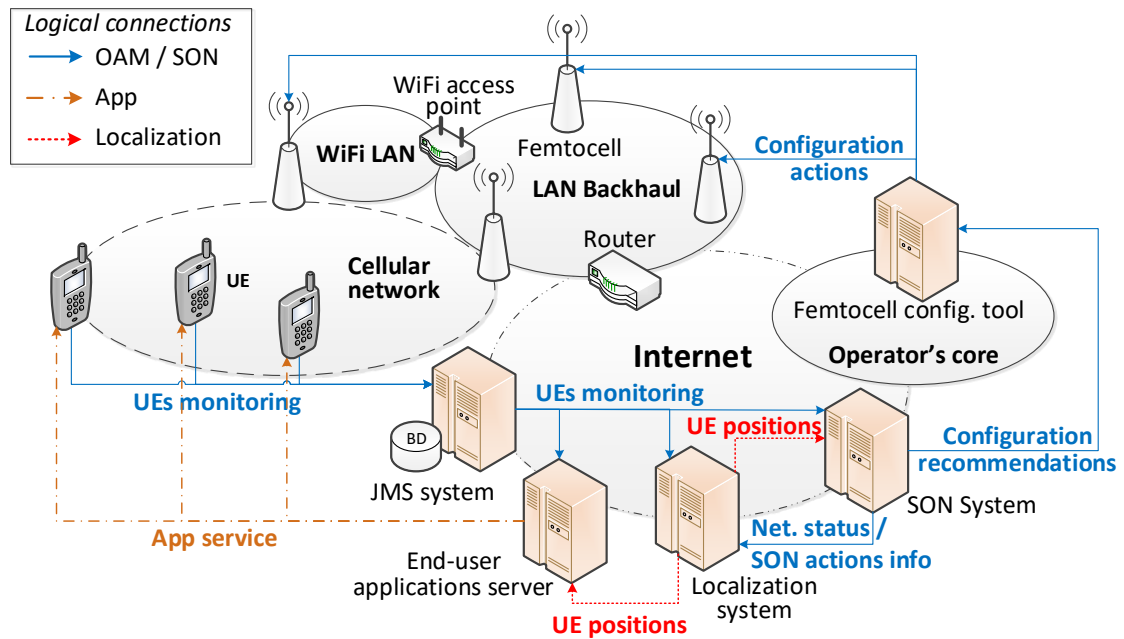

Figure A.4: Testbed entities interaction.

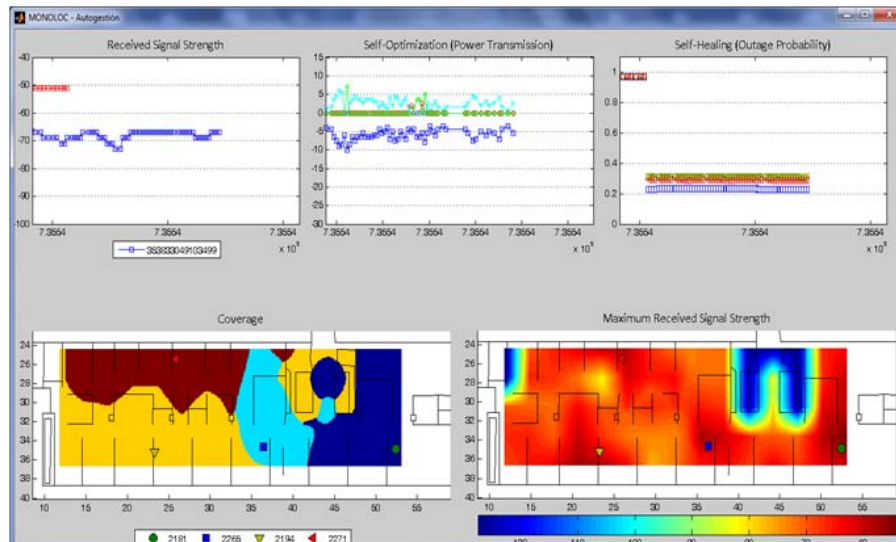

Figure A.5: Testbed SON monitoring GUI.



UNIVERSIDAD  
DE MÁLAGA

# Appendix B

## Summary (Spanish)

### Content

---

B.1	Introducción . . . . .	184
B.1.1	Objetivos . . . . .	187
B.1.2	Organización del trabajo . . . . .	188
B.2	Perspectiva de las redes celulares . . . . .	189
B.3	SON, auto-curación y contexto en entornos de celdas pequeñas . . . . .	191
B.3.1	Auto-curación . . . . .	192
B.3.2	Retos de las celdas pequeñas para la auto-curación . . . . .	192
B.3.3	Conciencia de contexto . . . . .	193
B.4	Arquitectura integrada de SON y contexto . . . . .	195
B.5	Framework para la auto-curación basada en contexto . . . . .	197
B.6	Indicadores contextualizados . . . . .	199
B.7	Enfoque distribuido para el análisis de celdas durmientes . . . . .	200
B.8	Contribuciones principales . . . . .	200
B.9	Lista de publicaciones . . . . .	202

---

La presente tesis se resume en este anexo, describiéndose su motivación, estado del arte y organización y proveyendo de una introducción a su temática y objetivos. Igualmente se describen los desarrollos realizados durante la misma.



## B.1 Introducción

Los últimos años han visto una revolución en los paradigmas de la comunicación móvil. En primer lugar, la aparición de los teléfonos inteligentes (*smartphones*) y *tablets* ha incrementado enormemente la cantidad de sensores y la capacidad de procesamiento distribuido disponible en las redes celulares. En segundo lugar, la introducción de las tarifas planas de datos, así como el continuo incremento de las velocidades de conexión, han impulsado a los operadores a intentar obtener mejores rendimientos de sus infraestructuras, reduciendo a su vez sus gastos de inversión y operación (*CApital EXpenditures* - CAPEX y *OPerational EXpenditures* - OPEX).

En esta situación el espectro de radiofrecuencia es un recurso escaso a fin de cubrir la creciente demanda de capacidad de los usuarios móviles. Uno de los principales enfoques seguidos para resolver este problema consiste en el incremento del número de celdas en la red mediante la introducción de estaciones base (*base stations* - *BSs*) con áreas de cobertura reducida, denominadas celdas pequeñas (*small cells*). Haciendo uso de celdas pequeñas es posible focalizar el despliegue de recursos adicionales a aquellas áreas donde sean necesarios debido a falta de cobertura o capacidad, permitiéndose además un mayor rehúso del espectro.

La introducción de las celdas pequeñas, de tecnologías como *Long Term Evolution* (LTE) y del uso de frecuencias más elevadas (y por tanto con mayores pérdidas de propagación), convierte la provisión de servicio en escenarios de interior (*indoor scenarios*) en un desafío para los operadores.

Teniendo celdas pequeñas, cada estación cubre un área más reducida que en los despliegues clásicos de macroceldas (de coberturas en el rango de centenares de metros), conduciendo esto a un aumento considerable en el número de estaciones que tienen que ser gestionadas por el operador de la red.

Además, con el fin de garantizar la calidad y fiabilidad del servicio y la compatibilidad del mismo con terminales de tecnologías anteriores (*legacy terminals*), en las redes móviles actuales hay coexistencia de múltiples tecnologías de acceso de radio (*radio access technologies* - RATs), como GSM, UMTS, LTE, etc. Las redes resultantes, aglutinan diferentes tecnologías y bandas sobre las mismas áreas y equipos, por lo que se las conoce como redes heterogéneas (*Heterogeneous network*, HetNets). Esta coexistencia de múltiples tecnologías de acceso implica sistemas aún más complejos y difíciles de gestionar.

Con el fin de hacer frente a este aumento de la complejidad de la infraestructura de comunicaciones móviles, la *Next Generation Mobile Networks (NGMN) Alliance* (la alianza por las redes móviles de próxima generación) y el *3rd Generation Partnership Project* (3GPP) establecieron el paradigma de redes auto-organizadas o



*self-organizing networks* (SON) [52]. Las funcionalidades SON tienen como objetivo lograr un rendimiento óptimo del servicio de comunicaciones a un coste reducido mediante la automatización de tareas de operación, administración y gestión de red (*Operations, Administration and Management* - OAM). SON consta de tres categorías básicas:

- **Auto-configuración (*self-configuration*):** acerca de las capacidades plug & play de los elementos de red para configurarse durante su instalación.
- **Auto-optimización (*self-optimization*):** sobre las funcionalidades de ajuste automático de los parámetros de la red (potencia transmitida, márgenes de traspaso, etc.) con el fin de obtener un rendimiento óptimo durante la vida de trabajo del sistema.
- **Auto-curación (*self-healing*):** centrado en la capacidad de la red para detectar, diagnosticar, compensar y recuperarse de fallos en los elementos de la red.

Los fallos en las redes móviles incluyen, entre otros, “caída” o fallo total de estaciones base, desconexiones en la red de retorno (*backhaul*), configuraciones erróneas, problemas de interferencia, pérdida de los sistemas de control, etc.

El manejo de fallos (*failure management*) en las celdas suele implicar el envío de ingenieros de campo a las diferentes instalaciones y equipos. Esto tiene un alto coste asociado, implica tiempos prolongados para la identificación de los fallos y recuperación de los mismos y un impacto importante en la provisión de servicio y la imagen de marca de los operadores. Por lo tanto, el desarrollo de mecanismos de auto-curación capaces de optimizar estos procesos es de importancia clave para las redes celulares, siendo el foco principal de esta tesis y sus publicaciones asociadas.

Así, la auto-curación tiene como objetivo la automatización de las diferentes tareas relacionadas con la gestión de fallos en redes celulares, incluyendo:

Esta tesis se centra en los mecanismos relacionados con la detección y diagnóstico de fallos, siendo estos los procesos más importantes e imprescindibles para llevar a cabo las posteriores acciones de compensación y recuperación.

Tanto la detección como la diagnosis se han basado hasta ahora en el análisis de variables propias de la red de comunicaciones, esto es, aquellas asociadas a la naturaleza y el desempeño de los elementos de la propia red. Así los mecanismos de auto-curación han consistido típicamente en algoritmos y métodos de aprendizaje que usan como entradas datos temporales asociados a variables del funcionamiento de la red, tales como *alarmas*, señales generadas por eventos tales como una desconexión o el cruce de un umbral por parte de alguna métrica; *contadores*, medidas

periódicas del número de eventos sucedidos en un cierto intervalo de tiempo (ej. número de llamadas caídas en una hora); e indicadores principales de rendimiento (*key performance indicators* - *KPI*), definidos habitualmente mediante fórmulas que combinan múltiples contadores, por ejemplo el KPI accesibilidad de se define como el ratio entre el número de conexiones satisfactorias y el número total de conexiones.

Los algoritmos de detección y diagnosis se fundamentan principalmente en el estudio de los valores instantáneos y/o las estadísticas y evolución temporal de estas variables para identificar cuando un elemento de red se encuentra en estado de fallo y para estimar la causa del mismo. Sin embargo, los entornos de celdas pequeñas poseen características (superposición de coberturas, alta dinamicidad en el número y ocupación de las celdas, monitorización reducida) que limitan la aplicación de análisis estadísticos clásicos a esos escenarios.

Por otro lado, los entornos con gran implantación de sensores y sistemas capaces de recolectar información se han extendido enormemente con la introducción de los teléfonos inteligentes. Así, una gran mayoría de usuarios portan dispositivos con gran conectividad (múltiples RAT celulares, WiFi, Bluetooth), equipados con una enorme cantidad de sensores (acelerómetros, cámara, GPS, etc.) y con acceso a datos de comportamiento del usuario (redes sociales, registros de actividad, etc.).

En este escenario se hace posible la adopción de mecanismos de conciencia de contexto o *context-awareness* consistentes en la utilización por parte de sistemas inteligentes de la información de contexto, es decir, variables asociadas con los usuarios y el entorno, incluyendo su posición, comportamiento, redes sociales, actividades, etc., de cara a mejorar la prestación de servicio y las aplicaciones [39].

Esta concepción de la conciencia de contexto apareció inicialmente en el campo de la computación ubicua, la cual considera escenarios donde los dispositivos y sensores se distribuyen ampliamente por el entorno. Así, una gran cantidad de información sobre el comportamiento de los usuarios y sus alrededores es accesible, y puede emplearse para adaptar los sistemas y, en consecuencia, lograr mejores servicios para el usuario final.

Una de las principales componentes de la información de contexto es la localización o posicionamiento de los usuarios en su entorno. A este respecto, uno de los retos clave para el mercado de telefonía móvil es encontrar aplicaciones determinantes o *killer applications* para los terminales (o equipos de usuario, *user equipments* - UEs, siguiendo la nomenclatura 3GPP) con el fin de aumentar los ingresos de los proveedores de servicios, los fabricantes y los desarrolladores. En este campo, los servicios basados en la localización (*location based services* - LBS) son la base de nuevas aplicaciones clave en multitud de campos: la publicidad, la domótica, el cuidado de la salud, la respuesta a emergencias, etc.

Los escenarios más prometedores para la implantación de LBS son las áreas medianas y grandes de interior (por ejemplo, edificios corporativos, centros comerciales, hospitales, aeropuertos...) dada su gran concentración de usuarios y las actividades que se realizan en ellos. Para proveer de localización a estos entornos, donde normalmente no hay acceso a la señal GPS/GNSS, se han desarrollado toda una serie de mecanismos de posicionamiento, que hacen cada vez más factible que la localización esté disponible en interiores de manera común [168][160]. De este modo, la localización de los usuarios/terminales se considera como uno de los principales componentes de la información de contexto a tener en cuenta por los mecanismos a desarrollar.

### B.1.1 Objetivos

Dado el estado de la gestión de redes celulares descrita en la sección anterior, los objetivos de esta tesis se centran en la integración de la información de contexto en el paradigma de redes auto-organizadas, y particularmente para la auto-curación, considerando las características especiales de los escenarios de celdas pequeñas de interior.

Para el desarrollo del estudio propuesto, se sigue un enfoque “de arriba abajo” (*top-down*), donde el análisis va desde la descripción técnica de la red celular, pasando por los detalles de la integración del contexto en los sistemas OAM/SON, hasta la definición y desarrollo de mecanismos de auto-curación específicos.

De esta manera, los principales objetivos de la tesis pueden resumirse en:

1. **Caracterización de las tecnologías celulares:** Dada la novedad de los estándares celulares más recientes (por ejemplo, LTE) y los despliegues de celdas pequeñas, es necesario un análisis de sus características principales para poder sustentar desarrollos posteriores. En especial se deben identificar aquellos rasgos que deben ser tenidos en cuenta para el desarrollo de los procedimientos OAM / SON basados en contexto.
2. **Definición de escenarios y aplicación de SON basado en contexto,** abarcando la definición de las condiciones y requisitos en los que se aplicaría la información de contexto para ayudar y mejorar los procedimientos de OAM
3. **Diseño de una arquitectura integrada de SON y contexto** capaz de aunar información de la red y de múltiples fuentes de contexto. Dado que estas arquitecturas no han sido debidamente abordadas en el pasado, su definición es indispensable para apoyar el desarrollo de mecanismos SON específicos. Esta definición arquitectural debe abarcar la definición funcional de la arquitectura

propuesta, así como modelos para su implementación física. Además, deben considerarse las posibilidades de utilizar información y procedimientos OAM / SON para el soporte a fuentes de contexto (por ejemplo, aplicaciones de localización basadas en el análisis de la señal radio).

4. **Desarrollo de sistemas de auto-curación basada en contexto** que hagan uso de técnicas automáticas de gestión de fallos que, utilizando diferentes fuentes de datos de contexto, deben mejorar el rendimiento de los enfoques anteriores. Así, se identifican diferentes sub-objetivos a partir de éste:
  - 4.1. *Establecer las características, objetivos y casos de uso* de auto-curación para guiar y evaluar el desarrollo de algoritmos y procedimientos específicos.
  - 4.2. *Definición de un marco de trabajo (“framework”) para la auto-curación basada en contexto*, esto es, el esquema general para integrar el contexto en los sistemas de gestión de fallos.
  - 4.3. *Desarrollo de mecanismos de auto-curación basados en el contexto*, refiriéndose a algoritmos y procedimientos específicos a definir.
5. **Implementación y evaluación a través de simulaciones y testbed real** de los mecanismos desarrollados, teniendo como objetivo el análisis de sus capacidades y desempeño.
6. **Documentación y perspectivas de la investigación:** finalmente la documentación y divulgación de los resultados de esta tesis es otro objetivo esencial. Estas se materializan en el presente informe y las múltiples publicaciones generadas a partir de la investigación desarrollada.

### B.1.2 Organización del trabajo

La memoria de tesis sigue el mismo esquema “de arriba abajo” de los objetivos presentados. Así, el documento se desarrolla siguiendo una estructura constituida por diferentes partes:

- La **parte I (*Background*)** presenta los preliminares y estado del arte necesarios para la correcta comprensión y desarrollo de la tesis. Así, ésta comienza con la introducción general a los objetivos y motivaciones del estudio en el capítulo 1. Después continúa con el capítulo 2, el cual describe las principales características de los actuales estándares de redes celulares y despliegues de celdas pequeñas.

- La **parte II** (*Context and SON Integration*) se ocupa de la integración propuesta de la información de contexto con OAM/SON. En primer lugar, el capítulo 3 presenta el estado detallado del arte de SON, y los enfoques de OAM con conocimiento de contexto, evaluando también las características específicas de SON y auto-curación en redes de celdas pequeñas. En segundo lugar, el capítulo chapter 4 describe la arquitectura propuesta para integrar el contexto con los sistemas OAM/SON pre-existentes.
- La **parte III** (*Context-aware Self-healing*) se centra en la descripción de los mecanismos desarrollados en esta tesis. El capítulo 5 propone un marco general para la auto-curación basada en contexto para entornos de celdas pequeñas. Se propone un caso de uso básico para demostrar las capacidades del enfoque en escenarios de femtoceldas, asumiendo el procesado detallado de la información individual de los UEs. Considerando los escenarios de tipo Picoceldas, con un número mucho mayor de UEs, el capítulo 6 propone el mecanismo de indicadores contextualizados (*contextualized indicators*) el cual permite un procesado de la información de contexto a más alto nivel y su aplicación directa como entrada a algoritmos basados en el análisis de métricas variables en el tiempo. Así, los indicadores contextualizados son aplicados para diferentes casos de uso, tanto al diagnóstico (en el mismo capítulo 6) como a la detección distribuida (en el capítulo 7).
- La **parte IV** (*Conclusions*) con el capítulo 8 proporciona las principales conclusiones del trabajo y bosqueja las perspectivas y líneas futuras de investigación.
- Este informe también incluye **anexos** adicionales. El anexo A se dedica a la descripción de las herramientas de evaluación y bancos de pruebas utilizados para la tesis. El anexo B es el presente resumen en español.

En las próximas secciones se realizará un resumen de los diferentes capítulos y se incluirá además la lista de publicaciones principales que soportan la tesis.

## B.2 Perspectiva de las redes celulares

El capítulo 2 presenta una visión general de la evolución histórica de los diferentes estándares de comunicaciones móviles como piedra fundacional de las innovaciones propuestas en esta tesis. En este sentido, los desarrollos definidos durante la misma se enfocan a ser lo más independiente posibles con respecto a las particularidades de las tecnologías celulares del momento, pero se analiza de manera continuada los

detalles de su implementación en los sistemas reales actuales, con especial foco en el conjunto de los estándares LTE (a veces referidos como estándares LTE/LTE-A o *familia LTE* [46][43]).

El desarrollo de LTE y LTE-A se engloba dentro del trabajo de 3GPP en la estandarización de la tecnología celular, donde LTE surge a partir de su versión (*release*) 8 de la necesidad de mejorar la provisión de servicio en la telefonía móvil celular, centrándose sus innovaciones tanto en un aumento de la velocidad de datos proporcionada al usuario, como en la mejora en la arquitectura de gestión de red de los operadores.

La tesis fija su escenario básico a partir de este estándar. En el mismo, pueden identificarse dos tipos principales de small cells para interior:

- **Picoceldas** (*picocells*) estaciones que siguen a la estructura y funcionalidad lógica de una estación base clásica de macroceldas, pero cubriendo un área de interior reducida (típicamente de hasta 200 metros).
- **Femtoceldas** (*femtocells*), también estaciones de baja potencia, con un área de cobertura en el orden de decenas de metros y con la característica especial de que hacen uso de una conexión no dedicada de banda ancha (por ejemplo, ADSL) para comunicarse con el resto de la infraestructura del operador.

Las macro y picoceldas son definidas en LTE como *evolved NodeBs* (eNBs) y las femtoceldas como *Home eNBs* (HeNBs). Los eNBs y HeNBs son capaces de gestionar los recursos radio de una celda y de coordinarse entre sí de cara a la movilidad de los UEs.

Igualmente se describe el modelo OAM de referencia en 3GPP [52] a partir de la cual se construyen las propuestas arquitectónicas posteriores, especialmente aquellas a definir en el capítulo 4, distinguiendo las actividades de los diferentes elementos de gestión de red. Los mecanismos SON se definen generalmente para niveles específicos de esta jerarquía de referencia OAM, cada nivel concreto está relacionado con el lapso de tiempo para la monitorización / configuración asociado [107] y también el nivel de abstracción sobre los elementos de la red. Estos se describen a continuación para los elementos principales del estándar:

- *Network Element* (NE): una entidad discreta de telecomunicaciones, que puede ser gestionada sobre una interfaz específica, ej.: el eNB. Actuando sobre el mismo elemento, los mecanismos SON asociados suelen realizar acciones de monitorización y cambio de parámetros en el rango de minutos/segundos.

- *Element Manager* (EM): provee de un paquete de funciones finales (end-user) para gestión de un conjunto de tipos de elementos de red (NEs) muy relacionados entre sí. Estas funciones pueden subdividirse en dos tipos:
  - *Element Management Functions*: Funciones de manejo de elementos.
  - *Network Management Functions*: Funciones de manejo de red.

En algunos casos, la funcionalidad EM puede residir en el NE.

- *Domain Manager* (DM): provee de funciones de gestión de elementos y funciones de gestión de dominio para una subred, actuando en periodos de horas/días.
- *Network Manager* (NM): provee un paquete de servicios finales con la responsabilidad de la gestión de una red. Esta soportado principalmente por los EMs, pero también podría acceder directamente a los NEs. Toda comunicación con la red está basada en interfaces abiertos y bien estandarizados, soportando la gestión de multi-vendor y multi-tecnología de NEs. DE manera clásica, las actividades a este nivel han sido realizadas con periodicidades de semanas/meses, dado el alto coste e impacto debido a que los cambios a esté nivel repercuten en la totalidad de la red.

También se analizan las perspectivas para las tecnologías futuras 5G [59][60][63][64]. En estas se espera un incremento exponencial de la de presencia escenarios ultradensos de gran complejidad [55][68] y donde la información de contexto será cada vez más detallada y disponible para la gestión de la red. Así, se prevee una creciente aplicabilidad y utilidad de los desarrollos propuestos en esta tesis.

### B.3 SON, auto-curación y contexto en entornos de celdas pequeñas

El capítulo 3 tiene tres objetivos principales. En primer lugar, presenta los principios y trabajos relacionados con los campos de investigación de esta tesis: SON y auto-curación. En segundo lugar, identifica las variables de contexto más importantes en redes celulares, describiendo los principales trabajos previos en el campo. En tercer lugar, describe y evalúa los principales desafíos para las actividades de OAM/SON en redes de celdas pequeñas, especialmente desde la perspectiva del análisis estadístico de sus métricas.

### B.3.1 Auto-curación

Aun siendo un campo de importancia clave, la aplicación de métodos automáticos para la solución de problemas en redes celulares ha sido hasta hace poco tiempo relativamente obviado en la bibliografía. Esto es especialmente cierto en comparación, por ejemplo, con el gran número de estudios sobre auto-optimización. Esto se debe principalmente a la dificultad de analizar casos de fallo, la limitada disponibilidad de conjuntos de datos sobre problemas reales y las variadas circunstancias y condiciones relacionadas con cada fallo.

Por otro lado, los trabajos anteriores sobre auto-curación se han centrado principalmente en macroceldas. La referencia de Barco et. al [29] y Hamalainen et al. [30] presentan un marco general para la auto-curación. Sin embargo, no hacen referencia a las características específicas de los escenarios de interior, la presencia de small cells o el uso de la información de contexto en dicha tarea.

Szilagyi y Novaczki [31], también introducen un framework para la detección y diagnosis automática, donde se desarrollan algoritmos específicos para la gestión de fallos en la red. Sin embargo, una vez más, no se aborda la aplicabilidad de la información de contexto o su implantación en escenarios de celdas pequeñas de interior. La continuación a dicho estudio realizada por Novaczki [32], introdujo algunas mejoras en el enfoque anterior, señalando además en sus conclusiones la posibilidad de utilizar la información de contexto para self-healing. Sin embargo, este trabajo no se incluye ningún desarrollo o definición específica a este respecto.

Las principales referencias para la detección y la diagnosis automáticas en redes celulares se basan en la correlación de alarmas [127][128][129] o en el análisis de los contadores y KPIs de las estaciones base y otros elementos de la red. Los métodos aplicados para este análisis son típicamente heurísticos, yendo desde simples controladores basados en umbrales o funciones lineales predefinidas, hasta algoritmos de minería de datos, inteligencia artificial y aprendizaje máquina más complejos. Así, los distintos trabajos se han centrado en la aplicación de diferentes mecanismos tales como redes Bayesianas [135][99], clasificadores bayesianos ingenuos (*naive Bayes classifiers*) [137], mapas auto-organizados (*self-organizing maps - SOM*) [139], funciones de rendimiento definidas de modo no supervisado [140] y algoritmos evolutivos [138].

### B.3.2 Retos de las celdas pequeñas para la auto-curación

Se han identificado diferentes características de los escenarios de celdas pequeñas de interior que suponen un reto para los enfoques desarrollados por los mecanismos de auto-curación de referencia, especialmente:

- Reporte reducido: las estaciones de celdas pequeñas se han diseñado para minimizar el número de alarmas y KPI reportados con el fin de evitar la saturación de la red debido a la señalización excesiva y con la intención de minimizar la carga computacional de las celdas, dada su normalmente baja capacidad de proceso (especialmente en el caso de las femtoceldas). Todo esto lleva a una importante reducción de la información disponible por parte de la arquitectura OAM para la detección y diagnóstico.
- Áreas de cobertura irregulares y superpuestas: los escenarios de interior, con sus paredes y obstáculos hacen que las áreas de celdas sean de forma irregular, con límites no claramente definidos y gran solapamiento entre sí y con la cobertura de macro. Muy a menudo, esto hace que la detección y el diagnóstico de fallos sea extremadamente difícil, dado que los mismos pueden no traducirse en agujeros de cobertura claros o interrupciones completas de la provisión de servicios en un lugar.
- La escasez y la variabilidad de la distribución de la información: En las soluciones de auto-curación clásicas, se necesita un gran conjunto de medidas con el fin de que los algoritmos den resultados estadísticamente confiables. Sin embargo, en las celdas pequeñas, dado el tamaño reducido del área de celda, los usuarios presentan un comportamiento muy dinámico con respecto a la celda, pudiendo moverse desde su centro a su borde muy rápidamente (segundos). Además, para una cierta estación base puede fácilmente no haber terminales conectados durante largos periodos de tiempo, en los cuales no habría suficiente información que permitiera la detección de un fallo en la misma.

### B.3.3 Conciencia de contexto

Debido a las características presentadas de los despliegues de celdas pequeñas, se propone el uso de mecanismos basados en contexto para la auto-curación. En este aspecto, solo algunos trabajos previos han definido usos limitados de ciertas variables de contexto. Así, las referencias previas giran principalmente en torno al uso de la posición del UE en escenarios macrocelulares, centrándose en la información recogida mediante *minimization of drive test* (MDT), mecanismo por el cual los terminales reportan información de eventos y medidas a las estaciones base [113][114]. En MDT los terminales son localizados mediante técnicas de posicionamiento en base a la señal de la red celular [216] o con soporte de posicionamiento por satélite.

En esta línea, los trabajos [143][144][145] definen diferentes casos de uso y mecanismos de procesamiento de la información de posición y medidas del UE. Otros trabajos hacen uso directamente de las medidas de avance temporal (*timing advance*)

de la señal entre el terminal y la estación base como variable de entrada adicional para la identificación de causas de fallo [147]. Estos trabajos hacen un uso limitado del contexto y se focalizan únicamente en los escenarios de macroceldas.

Otros trabajos han definido casos de uso y aplicaciones específicas donde la conciencia del contexto puede mejorar los sistemas de telecomunicaciones. Así, la referencia [57] reflexiona sobre las posibilidades introducidas por el conocimiento de la ubicación de los UEs aplicado a los mecanismos físicos, de control de acceso, de red y de capas superiores del sistema de comunicación. Las ventajas presentadas son amplias y se identifican diferentes desafíos, particularmente desde la perspectiva del modelado de canales y la señalización. Sin embargo, las funciones generales de SON no son abordadas y sólo se mencionan algunos casos de uso específicos de SON (por ejemplo, balance de carga)

El trabajo en [153] presenta una metodología para la configuración de estación base LTE basada en contexto. Sin embargo, en dicho trabajo el contexto refiere sólo a un subconjunto extremadamente limitado de tal información, teniendo en cuenta únicamente el conocimiento sobre la topología de red.

La referencia [149] propone un esquema de obtención de información de contexto de los usuarios reales de servicios de comunicaciones, presentando un *framework* para el uso de la información de contexto sobre los servicios de comunicación. Trabajos posteriores proveen casos de uso específicos en esta línea, tales como las comunicaciones por satélite [150] o la adaptación de los servicios de comunicación a las necesidades específicas de los usuarios [151]. Estos trabajos hacen un análisis centrado en el procesado de las variables de contexto y la adaptación de servicio a los requisitos de los UEs. Sin embargo, no entran en la definición de mecanismos que permitan aplicar la información de contexto a las actividades OAM/SON, para auto-curación o teniendo en cuenta las particularidades de los escenarios de celdas pequeñas de interior.

Por otro lado, la recomendación técnica de 3GPP [152] (cuya primera versión es de marzo de 2016) proporciona un estudio de alto nivel sobre la prestación de servicios conscientes del contexto, centrada en el cacheo o almacenamiento de contenido y el uso de proxies de mejora de rendimiento (*performance enhancing proxies*-PEPs) basados en la demanda extremo a extremo de los UEs, especialmente para servicios de video. De nuevo, dicho enfoque tampoco aborda los objetivos de la presente tesis en el campo de SON, auto-curación y las variables de contexto a considerar en nuestro estudio.

## B.4 Arquitectura integrada de SON y contexto

En el capítulo 4 de este trabajo se ha definido una arquitectura OAM que aglutine el uso de información de contexto con las operaciones propias de OAM/SON de una red celular.

Las directrices principales para el diseño de dicha arquitectura han sido:

- Conformidad con el estándar: La arquitectura debe seguir en la medida de lo posible el modelo 3GPP, haciendo uso de los interfaces ya definidos en el mismo o siendo capaz de integrarse en la misma.
- Integración con mecanismos previos OAM: las nuevas funcionalidades deben coordinarse de manera no intrusiva con los mecanismos de gestión actualmente en funcionamiento.
- Versatilidad en las comunicaciones: permitiendo en lo posible la libertad de interacción entre elementos.
- Señalización reducida: de modo que el coste en términos de señalización de gestión no congestione el núcleo de red del operador.
- Velocidad de la gestión: permitiendo una rápida monitorización y ejecución de acciones sobre la red.
- Posibilidad de implementación comercial: Aplicabilidad desde un punto de vista de las condicionantes económicas y sociales reales.

Teniendo en cuenta estos objetivos la arquitectura OAM propuesta se define mediante varias entidades interrelacionadas. Aquí nuestro sistema seguirá un enfoque híbrido. De esta manera la arquitectura de OAM centralizada clásica (comúnmente seguida por los operadores) puede ser reutilizada, mientras que, al mismo tiempo, se permite la implementación de nuevos mecanismos distribuidos.

Para las funciones de SON, se mantiene la arquitectura 3GPP OAM, añadiendo nuevas capacidades, funciones, entidades e interfaces a los ya presentes en la norma. Sin embargo, para la entidad centralizada más baja en la arquitectura 3GPP que gestiona múltiples elementos, el DM, los intervalos de tiempo son todavía elevados (en el rango de horas). Además, el DM generalmente opera en subredes no solapadas y cubre por lo general áreas mucho más grandes que un despliegue de interior de un escenario específico (por ejemplo: en una región o ciudad, en vez de, por ejemplo,

un despliegue en un centro comercial). Por lo tanto, los mecanismos SON implementados en el nivel de DM no se consideran los más adecuados para aprovechar todas las ventajas de la información de contexto.

Además, puede ser deseable que los elementos estándar OAM incluyan sólo las funciones no relacionadas con la información de contexto, de manera que las herramientas de arquitectura y sistemas heredados estándar sigan pudiendo ejecutarse sin problemas en el caso de que no haya información de contexto disponible.

Por lo tanto, se propone un nuevo bloque funcional de OAM, el sistema OAM de conciencia de contexto (*OAM Context-Aware System* - OCAS), para dar soporte a los nuevos mecanismos SON propuestos. El OCAS supone una nueva entidad lógica centralizada propuesta para formar parte de los niveles bajos de la jerarquía OAM. Este bloque se define como el encargado de la gestión del conjunto de celdas pequeñas en un área específica de interior y si es posible con conexión local y directa (por ejemplo: Ethernet) con los elementos bajo su gestión. De esta manera, la señalización no se propaga a la red de acceso o de transporte del operador, reduciendo al mínimo la congestión y permitiendo una reducción del tiempo de respuesta y costes computacionales para el resto de los elementos de OAM.

El OCAS implementa las siguientes funciones:

- Registra fuentes de información de contexto disponibles (context sources - CSs) y obtiene información de contexto de los usuarios (localización, estado, etc.) a partir de las mismas.
- Actúa como coordinador para la interacción entre los elementos de OAM de la red móvil, algoritmos SON y fuentes de contexto.
- Implementa funciones SON basadas en información de contexto.
- Comunica los resultados de los algoritmos SON a los elementos estándar de OAM de manera que pueda recibir autorización para aplicar cambios en la red o informar al plano OAM de fallos detectados/diagnosticados. Los comandos de configuración de parámetros pueden ser aplicados a los elementos de la red (ej.: una femtocelda) directamente por el OCAS o a través de los elementos estándar. Dependerá de la decisión del operador habilitar y otorgar permisos de configuración al OCAS.
- Además, los UEs pueden incorporar funciones de monitorización y reporte adicionales (M/R) para que informen directamente al OCAS proporcionando información precisa sobre el estado de la red. Esta capacidad de M/R puede ser parte de las aplicaciones basadas en contexto presentes en los terminales (por

ejemplo, una aplicación de navegación y posicionamiento) o ser implementadas por medio de llamadas directas a la API del terminal.

La arquitectura así propuesta es evaluada teniendo en cuenta su capacidad para reducir la periodicidad de los mecanismos SON (es decir, cada cuanto estos pueden aplicar cambios en la red) y en términos de las ventajas de hacer uso de la información de contexto. Igualmente se analiza el impacto en términos de señalización de la introducción de información de contexto en la red, demostrándose que su uso puede generalizarse para la capacidad de los sistemas de backhaul sin sobrecargar de manera relevante la red ni siquiera si las variables más comunes de contexto (aplicación en uso, posición, etc.) son recolectadas de manera continua y con alta periodicidad de un número de UEs elevado.

## B.5 Framework para la auto-curación basada en contexto

En el capítulo 5 se define un nuevo marco lógico capaz de dar soporte a mecanismos de auto-curación basados en contexto. Éste se considera indispensable para permitir el desarrollo nuevos algoritmos de detección y diagnóstico de fallo capaces de hacer frente a las características particulares de los escenarios de interior de celdas pequeñas.

El marco propuesto permite el procesamiento individual de datos recopilados por los UEs y otras fuentes de contexto. Además se analiza los condicionantes de su implementación en redes reales y en base a la arquitectura definida en el capítulo 4. Siguiendo este esquema, los terminales de usuario reportan indicadores clásicos de la red (por ejemplo: potencia recibida, identificador de celda servidora) e información de contexto (tiempo, posición, actividad, etc.). De este modo, es posible superponerse a las limitaciones comentadas para la auto-curación en escenarios de celdas pequeñas (es decir, reportes reducidos, coberturas irregulares, escasez de medidas, etc.).

El sistema propuesto comprende los siguientes bloques principales:

- Adquisición indicadores (*indicators acquisition*): es el encargado de recoger mediciones procedentes de la red móvil y los UEs. Las mediciones se acumulan en diferentes buffers, que en el modelo propuesto, se definen de manera individual para cada terminal. De las muestras acumuladas en cada buffer, se selecciona un subconjunto en base a la ventana de perfil (*profiling window*), es

decir, un grupo de muestras que será utilizado por el bloque de cálculo del perfil estadístico para generar la distribución actual del indicador reportado por un terminal (*terminal current profile*). El número de medidas consideradas en esta ventana tiene que ser lo suficientemente grande como para permitir descartar comportamientos espurios que pudieran llevar a un diagnóstico falso. Al mismo tiempo, debe ser lo suficientemente corto para permitir una respuesta rápida a los fallos en la red.

- Adquisición contexto (*context acquisition*): obtiene información del contexto de cada terminal a través de estos o a partir de datos obtenidos de otras fuentes externas de información, como los servidores de posicionamiento, redes sociales, aplicaciones de planificación de trabajo, etc.
- Agregación contexto (*context aggregation*): se encarga de asociar el contexto actual con situaciones previamente guardadas. Para ello, se pueden implementar diferentes algoritmos y técnicas de minería de datos con el fin de definir una puntuación de similitud entre el contexto actual de un terminal y aquellos previamente guardados. Una vez realizada dicha asociación, este bloque recupera el perfil contextualizado del indicador (*indicator contextualized profile*) esto es, la distribución de un indicador (ej.: un KPI) para situaciones anteriores con el mismo o similar contexto. Por ejemplo, el perfil del indicador con respecto a los valores tomados anteriormente a la misma hora y en la misma área actual del terminal.
- Motor de inferencia (*inference engine*): se dedica a la detección de los problemas de red, así como del diagnóstico de sus causas. Éste calculará la desviación entre cada distribución actual de un KPI con respecto a los perfiles anteriores contextualizados obtenidos a partir del bloque de agregación contexto.
- Actualización de registro (*record update*): está a cargo de mantener la base de datos de las medidas históricas de KPIs y contexto. También esta base de datos se amplía por la adición de mediciones contextualizadas reportadas durante el funcionamiento del sistema.

Finalmente se define un mecanismo de detección basado en este esquema, consistente en el análisis conjunto de la desviación de la media entre el perfil actual de potencia recibida y el perfil contextualizado de indicador (que representa los valores de potencia esperables dado el contexto del terminal). Este algoritmo es evaluado sobre un testbed real, combinando mediciones procedentes de varios UEs de manera simultánea. En el mismo se demuestra que, en comparación con los posibles análisis no-contextualizados, el enfoque propuesto permite la identificación de los fallos en las estaciones base incluso antes de producirse degradaciones relevantes en el rendimiento del servicio.

## B.6 Indicadores contextualizados

En el capítulo 6 se presenta un nuevo enfoque para la integración de la información del contexto en la auto-curación. Esto se logra mediante la propuesta de *indicadores contextualizados*, consistentes en métricas que combinan las mediciones de rendimiento de la red y la información de contexto del UE. Estos indicadores tienen la ventaja de ser fáciles de integrar en los mecanismos habitualmente usados en detección y diagnóstico y pueden aplicarse indistintamente para entornos de macro-celdas y celdas pequeñas. Sin embargo, al igual que el resto de la tesis, su desarrollo y aplicación se centra en escenarios de celdas pequeñas de interior, que son los que implican mayores desafíos desde la perspectiva de la auto-curación y por lo tanto los que más pueden beneficiarse del mecanismo propuesto.

Así, las principales contribuciones del capítulo incluyen, en primer lugar, la definición del enfoque de indicadores contextualizados como una forma de introducir información de contexto en los actuales mecanismos de auto-curación para redes celulares. Esto se hace mediante la utilización del concepto de pesos de muestras (“sample weights”) originalmente aplicado en encuestas sociales [185], para la integración de los valores de variables de contexto en métricas de la red de telecomunicación.

En segundo lugar, la formulación matemática de este enfoque es descrita de una manera integral, permitiendo la definición y aplicación de cualquier conjunto de variables mediante la definición de diferentes *máscaras de contexto*. De este modo se establece un sistema para el “pesado” o valoración estadística dinámica de las medidas de los UEs en base a su contexto (ej. posición, aplicación en uso). Esto permite generar indicadores específicos contextualizados, tales como nivel medio de potencia recibida cerca de una celda, throughput de los usuarios de una aplicación específica, calidad en el borde de la celda, etc.

En tercer lugar, se integran estos indicadores contextualizados en un esquema de diagnóstico para su uso en redes celulares y se analizan las implicaciones del enfoque propuesto tanto por parte de los usuarios como de los operadores.

Finalmente, el método propuesto es evaluado en un escenario de celdas de interior y para un determinado conjunto de máscaras de contexto. En este escenario se simulan diferentes casos de fallo y se valora el enfoque propuesto en comparación con mecanismos no basados en contexto, mostrando un rendimiento muy superior para la diagnosis de fallos comunes en estos despliegues.

## B.7 Enfoque distribuido para el análisis de celdas durmientes

Tras el desarrollo de los indicadores contextualizados, se consideró necesaria la adopción de enfoques distribuidos para lograr implementaciones más eficientes y robustas, especialmente para su aplicación para casos de celdas durmientes (*sleeping cells*).

El caso de celda durmiente es uno de los problemas más críticos para los despliegues celulares, consistente en la interrupción del servicio por parte de una estación celular que funciona correctamente desde el punto de vista del sistema de monitorización. Típicamente, este tipo de fallo no es directamente detectable por los operadores y puede conducir a graves degradaciones en la prestación de servicio. Comúnmente este problema se ha gestionado mediante el análisis centralizado de los indicadores de rendimiento de la red. Sin embargo, esas soluciones no son adecuadas para los nuevos escenarios de celdas pequeñas ultra densas que caracterizarán los despliegues 5G. De este modo, se necesitan nuevos enfoques para hacer frente al alto nivel de superposición de celdas, así como al gran número de elementos de red a gestionar.

Ante esta situación, se define un mecanismo en el que en cada grupo de celdas pequeñas estas pueden monitorizarse periódicamente entre sí y detectar y diagnosticar casos de fallo sin necesidad de intervención de los elementos del núcleo de red. El proceso de detección definido se inicia con una *fase individual*, donde cada BSs recoge datos de la potencia recibida y la posición de los UEs bajo su servicio. Después continúa con un paso de *distribución*, donde la información procesada se comparte entre las diferentes BSs, tras lo cual cada una de ellas puede realizar la *computación* del estado de sus vecinas. Esto se realiza en base a una aplicación original del clasificador bayesiano ingenuo pesado (*weighted naive Bayes classifier*)[204]. Si se detecta el estado de fallo en alguna de las celdas, las BSs pueden alcanzar un *consenso* entre sus resultados y realizar funciones adicionales de confirmación y chequeo del estado de la conectividad de las mismas para diagnosticar la causa raíz del problema. Las capacidades de este mecanismo se evalúan en un escenario simulado, mostrando la viabilidad y utilidad del enfoque propuesto.

## B.8 Contribuciones principales

Esta tesis ha abordado la tarea de integrar información de contexto dentro de los sistemas de SON, centrándose en la auto-curación de escenarios de celdas pequeñas de interior. En este sentido, las principales contribuciones del presente trabajo han

sido:

- **La evaluación de las características de las redes de celdas pequeñas**, identificando los principales desafíos desde el punto de vista de la aplicación de mecanismos clásicos de redes auto-organizadas y, especialmente, de auto-curación. Se ha evaluado cómo las características de estos despliegues hacen que se reduzca de manera sustancial el desempeño de los enfoques estadísticos típicamente seguidos por estos mecanismos. Esto es debido especialmente a la superposición entre celdas y la naturaleza dinámica de la demanda de los usuarios. Por el contrario, las variables de contexto se identifican como una fuente de información esencial para superar estos desafíos. Esto hace que su inclusión como parte de la gestión de la red celular sea considerada indispensable.
- **Una arquitectura SON** ha sido propuesta para la integración de la información de contexto en los sistemas SON celulares. Ésta se ha definido para permitir de manera simultánea mecanismos SON a nivel local (ej. para una subred de celdas pequeñas específica) y centralizada, capaces de coordinarse entre sí. Esta arquitectura también soporta la inclusión de mecanismos SON en los distintos niveles, ámbitos y entidades del plano de gestión, desde los UE hasta la red general. El enfoque propuesto se ha modelado teniendo en cuenta la arquitectura 3GPP existente, al tiempo que se proponen adiciones para minimizar el impacto de la señalización relacionada con el contexto, así como para reducir la periodicidad general de los mecanismos SON.
- **Un “framework” para la auto-curación basada en contexto** ha sido establecido para apoyar los mecanismos de auto-curación que hagan uso de los datos de la red y las variables de contexto, creando un enfoque general para estos mecanismos. En este marco se pueden definir diferentes técnicas basadas en el análisis del desempeño de la red teniendo en cuenta el contexto individual de los UE y medidas relacionadas con la red de comunicaciones.
- **Los indicadores contextualizados** se han propuesto como un nuevo enfoque para permitir la integración de variables de contexto y métricas de rendimiento clásicas. Su cálculo se ha definido basándose en el uso de pesos de muestras (“sample weights”) generadas en función de cualquier variable de contexto. A partir de estos y de los datos de rendimiento de la red, se calculan los nuevos indicadores contextualizados. De esta manera, el enfoque define la inserción de cualquier variable de contexto, comúnmente muy complejas de procesar, en la generación de métricas temporales con la misma forma que los indicadores (ej. KPIs) clásicos. De este modo los indicadores contextualizados pueden

usarse como entrada de mecanismos de aprendizaje automático basados en el análisis de series temporales, facilitando su uso y adopción en entornos reales.

- **Nuevos mecanismos de auto-curación basados en el contexto** han sido definidos para abordar diferentes casos de uso de detección y diagnóstico. Especialmente, los indicadores contextualizados propuestos han sido aplicados inicialmente en el diagnóstico de problemas de calidad de cobertura e interferencia. Además, se ha propuesto un sistema distribuido para la detección y diagnóstico de problemas de celdas durmientes. Estos mecanismos han sido probados en escenarios clave y se han evaluado considerando las inexactitudes reales en las fuentes de contexto, en particular en la localización en interiores de UEs, mostrando grandes mejoras con respecto a los enfoques anteriores.

## B.9 Lista de publicaciones

Las diferentes publicaciones y trabajos de divulgación generados durante esta investigación son listados distinguiendo primero aquellas contribuciones que soportan la tesis.

### Artículos de revista

- [1] S. Fortes, R. Barco, and A. Aguilar-Garcia, “Location-based distributed sleeping cell detection and root cause analysis for 5G ultra-dense networks,” *EURASIP Journal on Wireless Communications and Networking*, vol. 2016, pp. 1–18, June 2016. (IF 2016: 1.529 - Q3).<sup>1</sup>
- [2] S. Fortes, A. A. Garcia, J. A. Fernandez-Luque, A. Garrido, and R. Barco, “Context-Aware Self-Healing: User Equipment as the Main Source of Information for Small-Cell Indoor Networks,” *IEEE Vehicular Technology Magazine*, vol. 11, pp. 76–85, March 2016. (IF 2016: 4.429 - Q1).
- [3] S. Fortes, R. Barco, A. Aguilar-García, and P. Muñoz, “Contextualized indicators for online failure diagnosis in cellular networks,” *Computer Networks*, vol. 82, pp. 96 – 113, April 2015. (IF 2015: 1.446 - Q2).
- [4] S. Fortes, A. Aguilar-García, R. Barco, F. Barba, J. Fernández-Luque, and A. Fernández-Durán, “Management architecture for location-aware self-

---

<sup>1</sup>Para los artículos publicados en revistas se incluye el factor de impacto (*impact factor* - IF) y cuartil (representado como QX, donde ‘X’ refleja su orden) de las mismas.

organizing LTE/LTE-A small cell networks,” *Communications Magazine, IEEE*, vol. 53, pp. 294–302, January 2015. (IF 2015: 5.125 - Q1).

*Contribuciones adicionales:*

- [5] A. Aguilar-Garcia, S. Fortes, A. F. Duran, and R. Barco, “Context-Aware Self-Optimization: Evolution Based on the Use Case of Load Balancing in Small-Cell Networks,” *IEEE Vehicular Technology Magazine*, vol. 11, pp. 86–95, March 2016. (IF 2016: 4.429 - Q1).
- [6] A. Aguilar-Garcia, S. Fortes, E. Colin, and R. Barco, “Enhancing RFID indoor localization with cellular technologies,” *EURASIP Journal on Wireless Communications and Networking*, vol. 2015, no. 1, 2015. (IF 2015: 0.627 - Q3).
- [7] A. Aguilar-Garcia, S. Fortes, M. Molina-García, J. Calle-Sánchez, J. I. Alonso, A. Garrido, A. Fernández-Durán, and R. Barco, “Location-aware self-organizing methods in femtocell networks,” *Computer Networks*, vol. 93, Part 1, pp. 125 – 140, 2015. (IF 2015: 1.446 - Q2).
- [8] A. Aguilar-Garcia, R. Barco, S. Fortes, and P. Muñoz, “Load balancing mechanisms for indoor temporarily overloaded heterogeneous femtocell networks,” *EURASIP Journal on Wireless Communications and Networking*, vol. 2015, p. 29, feb 2015. (IF 2015: 0.627 - Q3).
- [9] P. Muñoz, R. Barco, and S. Fortes, “Conflict Resolution Between Load Balancing and Handover Optimization in LTE Networks,” *Communications Letters, IEEE*, vol. 18, pp. 1795–1798, Oct 2014. (IF 2014: 1.268 - Q2).

## Patentes

- [10] S. Fortes, R. Barco, and I. Serrano, “Cellular Network Management Based on Automatic Social-Data Acquisition.” International Patent. Filing reference PCT/EP2017/060312. Filled on May, 1, 2017.
- [11] S. Fortes, R. Barco, P. Muñoz Luengo, and I. Serrano, “Method and Network Node for Detecting Degradation of Metric of Telecommunications Network.” International Patent. Filing reference PCT/EP2016/064144. Filled on June, 20, 2016.

## Conferencias y workshops internacionales

- [12] S. Fortes, P. Oliver, M. Toril, D. Palacios, S. Luna, and R. Barco, “Future 5G SON: University of Málaga - Mobilenet Group Approach and Perspectives: MobileNet team and Self-healing/optimization team - research topics,” in *IRACON 2nd MC meeting and first technical meeting*, September 2016.
- [13] S. Fortes, A. Aguilar-Garcia, J. A. Fernandez-Luque, A. Garrido, and R. Barco, “Location-Based User Equipment Identification of Failures in Femtocell Networks,” in *IRACON 2nd MC meeting and first technical meeting*, May 2016.
- [14] S. Fortes, R. Barco, A. Aguilar-García, and P. Muñoz, “Integration of Mobile Context in the Diagnosis of Small Cell Networks,” in *Joint NEWCOM/COST Workshop on Wireless Communications - JNCW 2015*, Oct 2015.
- [15] S. Fortes, R. Barco, and A. Aguilar-García, “Location-Based Distributed Failure Management for 5G Ultra-Dense Small Cell Networks,” in *Workshop on Evolution of Radio Access Network Technologies towards 5G*, May 2015.
- [16] S. Fortes, R. Barco, and A. Aguilar-García, “Integration of Indoor Positioning into Self-Organizing Small Cell Systems,” in *12th IC1004 MC and Scientific Meeting*, Jan 2015.

### *Contribuciones adicionales:*

- [17] A. Aguilar-García, S. Fortes, E. Collins, and R. Barco, “Enhancing Localization Accuracy with Multi-Antenna UHF RFID Fingerprinting,” in *IPIN 2015, Sixth International Conference on Indoor Positioning and Indoor Navigation*, Oct 2015.
- [18] A. Aguilar-García, R. Barco, S. Fortes, and P. Muñoz, “Analysis of overload indicators for traffic balance in indoor femtocell networks,” in *13th IC1004 MC and Scientific Meeting*, May 2015.

## Conferencias y workshops nacionales

- [19] S. Fortes, A. Aguilar-García, and R. Barco, “Identificación de Fallos Radio en Entornos Celulares Localizados de Interior,” in *XXX Simposium Nacional de la Unión Científica Internacional de Radio - URSI 2015*, Sep 2015.

- [20] S. Fortes, A. Aguilar-García, and R. Barco, “Detección de Celda Durmiente en Entornos Localizados de Femtoceldas,” in *XXIX Simposium Nacional de la Unión Científica Internacional de Radio - URSI 2014*, Sep 2014.
- [21] S. Fortes, A. Aguilar-Garcia, and R. Barco, “Location-Based User Equipment Identification of Failures in Femtocell Networks: Self-healing,” in *Workshop sobre localización en interiores con small cells. Conclusiones del proyecto MONOLOC*, Alcatel-Lucent, Nov 2014. Accessed: 2017-03-01.
- [22] S. Fortes, A. Aguilar-García, R. Barco, F. Barba, J. Fernández-Luque, and A. Fernández-Durán, “Diseño Integrado de Redes Auto-Organizadas LTE/LTE-A y Posicionamiento en Interiores,” in *XXVIII Simposium Nacional de la Unión Científica Internacional de Radio - URSI 2013*, Sep 2013.

*Contribuciones adicionales:*

- [23] A. Aguilar-García, S. Fortes, and R. Barco, “Análisis de indicadores para el balance de carga en redes de femtoceldas,” in *XXX Simposium Nacional de la Unión Científica Internacional de Radio - URSI 2015*, Sep 2015.
- [24] A. Aguilar-García, S. Fortes, and R. Barco, “Información de contexto en la auto-gestión de redes small cells,” in *XXIX Simposium Nacional de la Unión Científica Internacional de Radio - URSI 2014*, Sep 2014.



UNIVERSIDAD  
DE MÁLAGA

# Bibliography

- [1] S. Fortes, R. Barco, and A. Aguilar-Garcia, “Location-based distributed sleeping cell detection and root cause analysis for 5G ultra-dense networks,” *EURASIP Journal on Wireless Communications and Networking*, vol. 2016, pp. 1–18, June 2016.
- [2] S. Fortes, A. A. Garcia, J. A. Fernandez-Luque, A. Garrido, and R. Barco, “Context-Aware Self-Healing: User Equipment as the Main Source of Information for Small-Cell Indoor Networks,” *IEEE Vehicular Technology Magazine*, vol. 11, pp. 76–85, March 2016.
- [3] S. Fortes, R. Barco, A. Aguilar-García, and P. Muñoz, “Contextualized indicators for online failure diagnosis in cellular networks,” *Computer Networks*, vol. 82, pp. 96 – 113, April 2015.
- [4] S. Fortes, A. Aguilar-García, R. Barco, F. Barba, J. Fernández-Luque, and A. Fernández-Durán, “Management architecture for location-aware self-organizing LTE/LTE-A small cell networks,” *Communications Magazine, IEEE*, vol. 53, pp. 294–302, January 2015.
- [5] A. Aguilar-Garcia, S. Fortes, A. F. Duran, and R. Barco, “Context-Aware Self-Optimization: Evolution Based on the Use Case of Load Balancing in Small-Cell Networks,” *IEEE Vehicular Technology Magazine*, vol. 11, pp. 86–95, March 2016.
- [6] A. Aguilar-Garcia, S. Fortes, E. Colin, and R. Barco, “Enhancing RFID indoor localization with cellular technologies,” *EURASIP Journal on Wireless Communications and Networking*, vol. 2015, no. 1, 2015.
- [7] A. Aguilar-Garcia, S. Fortes, M. Molina-García, J. Calle-Sánchez, J. I. Alonso, A. Garrido, A. Fernández-Durán, and R. Barco, “Location-aware self-organizing methods in femtocell networks,” *Computer Networks*, vol. 93, Part 1, pp. 125 – 140, 2015.
- [8] A. Aguilar-Garcia, R. Barco, S. Fortes, and P. Muñoz, “Load balancing mechanisms for indoor temporarily overloaded heterogeneous femtocell networks,” *EURASIP Journal on Wireless Communications and Networking*, vol. 2015, p. 29, feb 2015.



- [9] P. Muñoz, R. Barco, and S. Fortes, “Conflict Resolution Between Load Balancing and Handover Optimization in LTE Networks,” *Communications Letters, IEEE*, vol. 18, pp. 1795–1798, Oct 2014.
- [10] S. Fortes, R. Barco, and I. Serrano, “Cellular Network Management Based on Automatic Social-Data Acquisition.” International Patent. Filing reference PCT/EP2017/060312. Filled on May, 1, 2017.
- [11] S. Fortes, R. Barco, P. Muñoz Luengo, and I. Serrano, “Method and Network Node for Detecting Degradation of Metric of Telecommunications Network.” International Patent. Filing reference PCT/EP2016/064144. Filled on June, 20, 2016.
- [12] S. Fortes, P. Oliver, M. Toril, D. Palacios, S. Luna, and R. Barco, “Future 5G SON: University of Málaga - Mobilenet Group Approach and Perspectives: MobileNet team and Self-healing/optimization team - research topics,” in *IRACON 2nd MC meeting and first technical meeting*, September 2016.
- [13] S. Fortes, A. Aguilar-Garcia, J. A. Fernandez-Luque, A. Garrido, and R. Barco, “Location-Based User Equipment Identification of Failures in Femtocell Networks,” in *IRACON 2nd MC meeting and first technical meeting*, May 2016.
- [14] S. Fortes, R. Barco, A. Aguilar-García, and P. Muñoz, “Integration of Mobile Context in the Diagnosis of Small Cell Networks,” in *Joint NEWCOM/COST Workshop on Wireless Communications - JNCW 2015*, Oct 2015.
- [15] S. Fortes, R. Barco, and A. Aguilar-García, “Location-Based Distributed Failure Management for 5G Ultra-Dense Small Cell Networks,” in *Workshop on Evolution of Radio Access Network Technologies towards 5G*, May 2015.
- [16] S. Fortes, R. Barco, and A. Aguilar-García, “Integration of Indoor Positioning into Self-Organizing Small Cell Systems,” in *12th IC1004 MC and Scientific Meeting*, Jan 2015.
- [17] A. Aguilar-García, S. Fortes, E. Collins, and R. Barco, “Enhancing Localization Accuracy with Multi-Antenna UHF RFID Fingerprinting,” in *IPIN 2015, Sixth International Conference on Indoor Positioning and Indoor Navigation*, Oct 2015.
- [18] A. Aguilar-García, R. Barco, S. Fortes, and P. Muñoz, “Analysis of overload indicators for traffic balance in indoor femtocell networks,” in *13th IC1004 MC and Scientific Meeting*, May 2015.
- [19] S. Fortes, A. Aguilar-García, and R. Barco, “Identificación de Fallos Radio en Entornos Celulares Localizados de Interior,” in *XXX Simposium Nacional de la Unión Científica Internacional de Radio - URSI 2015*, Sep 2015.
- [20] S. Fortes, A. Aguilar-García, and R. Barco, “Detección de Celda Durmiente en Entornos Localizados de Femtoceldas,” in *XXIX Simposium Nacional de la Unión Científica Internacional de Radio - URSI 2014*, Sep 2014.



- [21] S. Fortes, A. Aguilar-García, and R. Barco, “Location-Based User Equipment Identification of Failures in Femtocell Networks: Self-healing,” in *Workshop sobre localización en interiores con small cells. Conclusiones del proyecto MONOLOC*, Alcatel-Lucent, Nov 2014. Accessed: 2017-03-01.
- [22] S. Fortes, A. Aguilar-García, R. Barco, F. Barba, J. Fernández-Luque, and A. Fernández-Durán, “Diseño Integrado de Redes Auto-Organizadas LTE/LTE-A y Posicionamiento en Interiores,” in *XXVIII Simposium Nacional de la Unión Científica Internacional de Radio - URSI 2013*, Sep 2013.
- [23] A. Aguilar-García, S. Fortes, and R. Barco, “Análisis de indicadores para el balance de carga en redes de femtoceldas,” in *XXX Simposium Nacional de la Unión Científica Internacional de Radio - URSI 2015*, Sep 2015.
- [24] A. Aguilar-García, S. Fortes, and R. Barco, “Información de contexto en la auto-gestión de redes small cells,” in *XXIX Simposium Nacional de la Unión Científica Internacional de Radio - URSI 2014*, Sep 2014.
- [25] Ericsson, “Ericsson Mobility Report. On the pulse of the networked society,” Whitepaper 1.0, Ericsson, SE-126 25 Stockholm, Sweden, Nov. 2015.
- [26] 3GPP, “Architecture enhancements for non-3GPP accesses,” TS 23.402, 3rd Generation Partnership Project (3GPP), 2015.
- [27] “Small Cell Forum - webpage.” <http://www.smallcellforum.org>. Accessed: 2017-03-01.
- [28] 3GPP, “Universal Mobile Telecommunications System (UMTS); LTE; Telecommunication management; Self-Organizing Networks (SON); Concepts and requirements, v.13.0.0 (Release 13),” TS 32.500, 3rd Generation Partnership Project (3GPP), 2016.
- [29] R. Barco, P. Lazaro, and P. Munoz, “A unified framework for self-healing in wireless networks,” *IEEE Communications Magazine*, vol. 50, pp. 134–142, December 2012.
- [30] M. Asghar, S. Hämmäläinen, and T. Ristaniemi, “Self-healing framework for LTE networks,” in *Computer Aided Modeling and Design of Communication Links and Networks (CAMAD), 2012 IEEE 17th International Workshop on*, pp. 159–161, Sept 2012.
- [31] P. Szilagyí and S. Novaczki, “An Automatic Detection and Diagnosis Framework for Mobile Communication Systems,” *Network and Service Management, IEEE Transactions on*, vol. 9, pp. 184–197, June 2012.
- [32] S. Novaczki, “An improved anomaly detection and diagnosis framework for mobile network operators,” in *Design of Reliable Communication Networks (DRCN), 2013 9th International Conference on the*, pp. 234–241, March 2013.



- [33] 3GPP, “Telecommunication management; Key Performance Indicators (KPI) for Evolved Universal Terrestrial Radio Access Network (E-UTRAN): Definitions (Release 11),” TS 32.450, 3rd Generation Partnership Project (3GPP), Sept. 2012.
- [34] W. Wang, J. Zhang, and Q. Zhang, “Cooperative cell outage detection in Self-Organizing femtocell networks,” in *INFOCOM, 2013 Proceedings IEEE*, pp. 782–790, April 2013.
- [35] W. Wang and Q. Zhang, “Local cooperation architecture for self-healing femtocell networks,” *IEEE Wireless Communications*, vol. 21, pp. 42–49, April 2014.
- [36] F. Guidolin, I. Pappalardo, A. Zanella, and M. Zorzi, “Context-Aware Handover Policies in HetNets,” *IEEE Transactions on Wireless Communications*, vol. 15, pp. 1895–1906, March 2016.
- [37] J. Khoriaty and H. Artail, “Coordinated multipoint in heterogeneous networks with overlapping microcell expanded regions,” in *Wireless and Mobile Computing, Networking and Communications (WiMob), 2015 IEEE 11th International Conference on*, pp. 289–295, Oct 2015.
- [38] Y. Li, W. Yuan, H. Xu, W. Song, R. Yang, Z. Zang, D. Lin, and Y. He, “Coordinated multipoint in heterogeneous networks with overlapping microcell expanded regions,” in *2015 International Conference on Intelligent Systems Research and Mechatronics Engineering (ISRME 2015)*, pp. 907–912, April 2015.
- [39] A. K. Dey, “Understanding and Using Context,” *Personal Ubiquitous Comput.*, vol. 5, pp. 4–7, Jan. 2001.
- [40] J. Simoes and T. Magedanz, *Handbook of Social Network Technologies and Applications*, ch. Understanding and Predicting Human Behavior for Social Communities, pp. 427–445. Boston, MA: Springer US, 2010.
- [41] J. M. Ruiz-Avilés, S. Luna-Ramírez, M. Toril, F. Ruiz, I. de la Bandera, P. M. Luengo, R. Barco, P. Lázaro, and V. Buenestado, “Design of a Computationally Efficient Dynamic System-Level Simulator for Enterprise LTE Femtocell Scenarios,” *J. Electrical and Computer Engineering*, vol. 2012, 2012.
- [42] MONOLOC, “MONOLOC Project - webpage.” <http://monoloc.grupoinnovati.com/eng/index.html>. Accessed: 2017-03-01.
- [43] “3GPP - webpage.” <http://www.3gpp.org/>. Accessed: 2017-03-01.
- [44] GSMA - GSM Association, “What is 3G/WCDMA?.” <http://www.gsma.com/aboutus/gsm-technology/3gwcma>. Accessed: 2017-03-01.
- [45] S. Dekleva, J. Shim, U. Varshney, and G. Knoerzer, “Evolution and Emerging Issues in Mobile Wireless Networks,” *Commun. ACM*, vol. 50, pp. 38–43, June 2007.



- [46] S. Ahmadi, “Chapter 1 - Introduction to LTE-Advanced,” in *LTE-Advanced* (S. Ahmadi, ed.), pp. 1 – 27, Academic Press, 2014.
- [47] K. Flynn, “LTE-Advanced Pro Ready to Go - webpage.” [http://www.3gpp.org/news-events/3gpp-news/1745-lte-advanced\\_pro](http://www.3gpp.org/news-events/3gpp-news/1745-lte-advanced_pro), oct 2015. Accessed: 2017-03-01.
- [48] R. A. Santos, V. R. Lincea, and A. Edwards-Block, *Broadband Wireless Access Networks for 4G: Theory, Application, and Experimentation*. Hershey, PA, USA: IGI Global, 1st ed., 2013.
- [49] 3GPP, “Evolved Universal Terrestrial Radio Access (E-UTRA); Physical channels and modulation,” TS 36.211, 3rd Generation Partnership Project (3GPP), July 2016.
- [50] 3GPP, “Evolved Universal Terrestrial Radio Access (E-UTRA) and Evolved Universal Terrestrial Radio Access Network (E-UTRAN); Overall description; Stage 2,” TS 36.300, 3rd Generation Partnership Project (3GPP), Jan. 2016.
- [51] 3GPP, “3rd Generation Partnership Project; Technical Specification Group Services and System Aspects; Architecture aspects of Home NodeB and Home eNodeB (Release 9),” TR 23.830, 3rd Generation Partnership Project (3GPP), Oct. 2009.
- [52] 3GPP, “Telecommunication management; Principles and high level requirements,” TS 32.101, 3rd Generation Partnership Project (3GPP), 1 2016.
- [53] 3GPP, “Telecommunication management; Radio Planning Tool Access (RPTA) Integration Reference Point (IRP); Requirements,” TS 28.667, 3rd Generation Partnership Project (3GPP), Jan. 2016.
- [54] R. W. H. Jr., “The University of Texas at Austin; Professor Robert W. Heath Jr. Research in wireless communication and signal processing; Heterogeneous Networks - webpage.” <http://www.profheath.org/research/heterogeneous-networks/>, oct 2015. Accessed: 2017-03-01.
- [55] D. López-Pérez, M. Ding, H. Claussen, and A. H. Jafari, “Towards 1 Gbps/UE in Cellular Systems: Understanding Ultra-Dense Small Cell Deployments,” *IEEE Communications Surveys Tutorials*, vol. 17, pp. 2078–2101, Fourthquarter 2015.
- [56] “What is 5G? 5G visions.” <http://www.gsmhistory.com/5g/>. Accessed: 2017-03-01.
- [57] R. Di Taranto, S. Muppisetty, R. Raulefs, D. Slock, T. Svensson, and H. Wymeersch, “Location-Aware Communications for 5G Networks: How location information can improve scalability, latency, and robustness of 5G,” *Signal Processing Magazine, IEEE*, vol. 31, pp. 102–112, Nov 2014.
- [58] Ericsson, “5G Radio Access, what is 5G?,” Whitepaper Uen 284 23-3204 Rev C, Ericsson, SE-126 25 Stockholm, Sweden, Apr. 2016.

- [59] 5G-INFRASTRUCTURE-PPP, “The 5G Infrastructure Public Private Partnership - webpage.” <http://5g-ppp.eu>. Accessed: 2017-03-01.
- [60] Fantastic5G, “Fantastic5G: flexible air interface for scalable service delivery within wireless communication networks of the 5th Generation - webpage.” <http://fantastic5g.eu/>. Accessed: 2017-03-01.
- [61] METIS-II, “METIS-II: Mobile and wireless communications Enablers for Twenty-twenty (2020) Information Society-II - webpage.” <http://metis-ii.5g-ppp.eu>. Accessed: 2017-03-01.
- [62] One5G, “One5G: E2E-aware Optimizations and advancements for the Network Edge of 5G New Radio - webpage.” <https://one5g.eu/>. Accessed: 2017-08-01.
- [63] I. Berberana, “5G and the IoT (Internet of Things).” Public conference of the Cámara Oficial de Comercio, Industria y Navegación de Málaga., Sep 2012.
- [64] NGNM, “NGMN 5G White Paper,” Whitepaper 1.0, Next Generation Mobile Networks Alliance, Feb. 2015.
- [65] D. Kreutz, F. M. V. Ramos, P. E. Veríssimo, C. E. Rothenberg, S. Azodolmolky, and S. Uhlig, “Software-Defined Networking: A Comprehensive Survey,” *Proceedings of the IEEE*, vol. 103, pp. 14–76, Jan 2015.
- [66] M. Chiosi, D. Clarke, P. Willis, A. Reid CenturyLink, J. Feger, M. Bugenhagen, W. Khan, M. Fargano, C. Cui, H. Deng, U. Michel, H. Damker KDDI, K. Ogaki, T. Matsuzaki NTT, M. Fukui, K. Shimano, D. Delisle, Q. Loudier, C. Koliass Telecom Italia, I. Guardini, E. Demaria, R. Minerva, A. Manzalini Telefonica, D. López, and F. Javier Ramón Salguero, “Network Functions Virtualisation: Introductory White Paper Network Functions Virtualisation,” whitepaper, ETSI, Oct. 2012.
- [67] Ericsson AB, “5G systems: enabling industry and society transformation,” tech. rep., Ericsson, Jan. 2015.
- [68] 3GPP, “Study on scenarios and requirements for next generation access technologies,” TR 38.913, 3rd Generation Partnership Project (3GPP), March 2017.
- [69] Q. Li, H. Niu, A. Papathanassiou, and G. Wu, “Edge Cloud and Underlay Networks: Empowering 5G Cell-Less Wireless Architecture,” in *European Wireless 2014; 20th European Wireless Conference; Proceedings of*, pp. 1–6, May 2014.
- [70] K. I. Pedersen, F. Frederiksen, C. Rosa, H. Nguyen, L. G. U. Garcia, and Y. Wang, “Carrier aggregation for LTE-advanced: functionality and performance aspects,” *IEEE Communications Magazine*, vol. 49, pp. 89–95, June 2011.
- [71] A. Bhamri, K. Hooli, and T. Lunttila, “Massive carrier aggregation in LTE-advanced pro: impact on uplink control information and corresponding enhancements,” *IEEE Communications Magazine*, vol. 54, pp. 92–97, May 2016.



- [72] R. Tao, L. Li, X. Chu, and J. Zhang, "Handover mechanism and performance evaluation for LTE-LAA systems," in *2016 IEEE 17th International Workshop on Signal Processing Advances in Wireless Communications (SPAWC)*, pp. 1–5, July 2016.
- [73] C. Rosa, K. Pedersen, H. Wang, P. H. Michaelsen, S. Barbera, E. Malkamaki, T. Henttonen, and B. Sebire, "Dual connectivity for LTE small cell evolution: functionality and performance aspects," *IEEE Communications Magazine*, vol. 54, pp. 137–143, June 2016.
- [74] C. Rosa, K. Pedersen, H. Wang, P. H. Michaelsen, S. Barbera, E. Malkamaki, T. Henttonen, and B. Sebire, "Dual connectivity for LTE small cell evolution: functionality and performance aspects," *IEEE Communications Magazine*, vol. 54, pp. 137–143, June 2016.
- [75] M. Lauridsen, L. C. Gimenez, I. Rodriguez, T. B. Sorensen, and P. Mogensen, "From LTE to 5G for Connected Mobility," *IEEE Communications Magazine*, vol. 55, pp. 156–162, March 2017.
- [76] K. Zheng, F. Hu, W. Wang, W. Xiang, and M. Dohler, "Radio resource allocation in LTE-advanced cellular networks with M2M communications," *IEEE Communications Magazine*, vol. 50, pp. 184–192, July 2012.
- [77] Y. Mehmood, C. Görg, M. Muehleisen, and A. Timm-Giel, "Mobile M2M communication architectures, upcoming challenges, applications, and future directions," *EURASIP Journal on Wireless Communications and Networking*, vol. 2015, no. 1, p. 250, 2015.
- [78] N. Alliance, "NGMN Alliance - webpage." <http://www.ngmn.org/>. Accessed: 2017-03-01.
- [79] S. Shen, "How to Cut Mobile Network Costs to Serve Emerging Markets," whitepaper, Gartner Inc, London UK, Nov. 2005.
- [80] NGNM, "Recommendation on SON and O&M Requirements," Whitepaper 1.23, Next Generation Mobile Networks Alliance, Dec. 2008.
- [81] L. Jorgueski, A. Pais, F. Gunnarsson, A. Centonza, and C. Willcock, "Self-organizing networks in 3GPP: standardization and future trends," *IEEE Communications Magazine*, vol. 52, pp. 28–34, December 2014.
- [82] S. Hämmäläinen, "Self-Organizing Networks in 3GPP LTE," in *Vehicular Technology Conference Fall (VTC 2009-Fall)*, 2009 IEEE 70th, pp. 1–2, Sept 2009.
- [83] J. Rodriguez, I. D. la Bandera, P. Munoz, and R. Barco, "Load Balancing in a Realistic Urban Scenario for LTE Networks," in *Vehicular Technology Conference (VTC Spring)*, 2011 IEEE 73rd, pp. 1–5, May 2011.



- [84] P. Munoz, R. Barco, D. Laselva, and P. Mogensen, “Mobility-based strategies for traffic steering in heterogeneous networks,” *IEEE Communications Magazine*, vol. 51, pp. 54–62, May 2013.
- [85] P. Muñoz, R. Barco, and I. de la Bandera, “On the Potential of Handover Parameter Optimization for Self-Organizing Networks,” *IEEE Transactions on Vehicular Technology*, vol. 62, pp. 1895–1905, Jun 2013.
- [86] E. Roth-Mandutz and A. Mitschele-Thiel, “LTE energy saving SON using fingerprinting for identification of cells to be activated,” in *Future Network and Mobile Summit (FutureNetworkSummit), 2013*, pp. 1–8, July 2013.
- [87] 3GPP, “Evolved Universal Terrestrial Radio Access Network (E-UTRAN); Self-configuring and self-optimizing network (SON) use cases and solutions, v.9.3.1 (Release 9),” TS 36.902, 3rd Generation Partnership Project (3GPP), 2011.
- [88] 3GPP, “Telecommunication Management; Automatic Neighbor Relation (ANR) management; Concepts and Requirements,” TS 32.511, 3rd Generation Partnership Project (3GPP), Jan. 2016.
- [89] 3GPP, “Telecommunication management; Fault Management; Part 1: 3G fault management requirements,” TS 32.111, 3rd Generation Partnership Project (3GPP), Jan. 2016.
- [90] 3GPP, “Telecommunication management; Fault Management; Part 2: Alarm Integration Reference Point (IRP): Information Service (IS),” TS 32.111, 3rd Generation Partnership Project (3GPP), Jan. 2016.
- [91] 3GPP, “Telecommunication management; Self-Organizing Networks (SON); Self-healing concepts and requirements,” TS 32.541, 3rd Generation Partnership Project (3GPP), Jan. 2016.
- [92] 3GPP, “Telecommunication management; Self-Organizing Networks (SON); Study on self-healing,” TR 32.823, 3rd Generation Partnership Project (3GPP), Oct. 2009.
- [93] M. Amirijoo, L. Jorgueski, T. Kurner, R. Litjens, M. Neuland, L. C. Schmelz, and U. Turke, “Cell outage management in LTE networks,” in *2009 6th International Symposium on Wireless Communication Systems*, pp. 600–604, Sept 2009.
- [94] European institute for Research and strategic studies in telecommunications EURESCOM, “Celtic-Plus webpage.” <https://www.celticplus.eu>. Accessed: 2017-03-01.
- [95] P. Stuckmann, Z. Altman, H. Dubreil, A. Ortega, R. Barco, M. Toril, M. Fernandez, M. Barry, S. McGrath, G. Blyth, P. Saidha, and L. M. Nielsen, “The EUREKA Gandalf project: monitoring and self-tuning techniques for heterogeneous radio access networks,” in *2005 IEEE 61st Vehicular Technology Conference*, vol. 4, pp. 2570–2574 Vol. 4, May 2005.



- [96] P. Stuckmann, Z. Altman, H. Dubreil, A. Ortega, R. Barco, M. Toril, M. Fernandez, M. Barry, S. McGrath, G. Blyth, P. Saidha, and L. M. Nielsen, "The EUREKA Gandalf project: monitoring and self-tuning techniques for heterogeneous radio access networks," in *2005 IEEE 61st Vehicular Technology Conference*, vol. 4, pp. 2570–2574 Vol. 4, May 2005.
- [97] Z. Altman, R. Skehill, R. Barco, L. Moltsen, R. Brennan, A. Samhat, R. Khanafer, H. Dubreil, M. Barry, and B. Solana, "The Celtic Gandalf framework," in *MELECON 2006 - 2006 IEEE Mediterranean Electrotechnical Conference*, pp. 595–598, May 2006.
- [98] R. Khanafer, L. Moltsen, H. Dubreil, Z. Altman, and R. Barco, "A Bayesian Approach for Automated Troubleshooting for UMTS Networks," in *2006 IEEE 17th International Symposium on Personal, Indoor and Mobile Radio Communications*, pp. 1–5, Sept 2006.
- [99] R. M. Khanafer, B. Solana, J. Triola, R. Barco, L. Moltsen, Z. Altman, and P. Lazaro, "Automated Diagnosis for UMTS Networks Using Bayesian Network Approach," *IEEE Transactions on Vehicular Technology*, vol. 57, pp. 2451–2461, July 2008.
- [100] European Commission, "FP7: The 7th Framework Programme funded European Research and Technological Development from 2007 until 2013 - webpage." <http://cordis.europa.eu/fp7/>. Accessed: 2017-03-01.
- [101] BeFEMTO project consortium, "BeFEMTO: Broadband Evolved FEMTO Networks - webpage." <http://www.ict-befemto.eu>. Accessed: 2017-03-01.
- [102] S. Mayrargue, A. De Domenico, E. C. Strinati, A. G. Serrano, L. Giupponi, M. Dohler, S. Uygungelen, Z. Bharucha, D. Marandin, S. Brueck, A. Garavaglia, M. Maqbool, M. Lalam, C. Palacios, M. Lopez, A. Ul Quddus, Y. Ko, A. Imran, M. Shariat, M. Bennis, H. Pennanen, C. H. Lima, and F. Pantisano, "D4.4 FINAL Integrated SON Techniques For Femtocells Radio Access," Deliverable D4.4, INFSO-ICT-248523 BeFEMTO, July FINAL.
- [103] Tyrrell, Alexander and Garavaglia, Andrea and Krendzel, Andrey and Marandin, Dimitry and Zdarsky, Frank and Mangues-Bafalluy, Josep and Giupponi, Lorenza and Palmowski, Manuel and López, Mariano and Lalam, Massinissa and Bennis, Mehdi and Shariat, Mehrdad and Arozarena, Pablo and Brueck, Stefan and Schmid, Stefan and Guo, Tao and Ko, Youngwook and Participant, Zubin Bharucha, "The BeFEMTO System Architecture," Deliverable D2.2, INFSO-ICT-248523 BeFEMTO, Jan. 2012.
- [104] SEMAFOUR project consortium, "SEMAFOUR: Self-Management for Unified Heterogeneous Radio Access Networks - webpage." <http://www.fp7-semafour.eu/>. Accessed: 2017-03-01.



- [105] O. Iacoboanea, B. Sayrac, S. B. Jemaa, and P. Bianchi, “Low complexity SON coordination using reinforcement learning,” in *2014 IEEE Global Communications Conference*, pp. 4406–4411, Dec 2014.
- [106] S. Hahn, D. Gotz, S. Lohmuller, L. C. Schmelz, A. Eisenblatter, and T. Kurner, “Classification of Cells Based on Mobile Network Context Information for the Management of SON Systems,” in *2015 IEEE 81st Vehicular Technology Conference (VTC Spring)*, pp. 1–5, May 2015.
- [107] S. Hämmäläinen, H. Sanneck, and C. Sartori, *LTE Self-Organising Networks (SON): Network Management Automation for Operational Efficiency*. Wiley, 2011.
- [108] O. Onireti, A. Imran, M. A. Imran, and R. Tafazolli, “Cell Outage Detection in Heterogeneous Networks with Separated Control and Data Plane,” in *European Wireless 2014; 20th European Wireless Conference*, pp. 1–6, May 2014.
- [109] D. M. Borsboom, “The theoretical status of latent variables,” *Psychological Review*, vol. 110, pp. 203–219, Apr. 2003.
- [110] TEMS™, “TEMS® | Testing, monitoring, and analytics of radio and core networks - webpage.” <http://www.tems.com/>. Accessed: 2017-03-01.
- [111] ROHDE&SCHWARZ, “R&S® ROMES4 Drive Test Software - webpage.” [https://www.rohde-schwarz.com/us/product/romes-productstartpage\\_63493-8650.html](https://www.rohde-schwarz.com/us/product/romes-productstartpage_63493-8650.html). Accessed: 2017-03-01.
- [112] J. Ramiro and K. Hamied, *Self-Organizing Networks (SON): Self-Planning, Self-Optimization and Self-Healing for GSM, UMTS and LTE*. Wiley Publishing, 1st ed., 2012.
- [113] W. Hapsari, A. Umesh, M. Iwamura, M. Tomala, B. Gyula, and B. Sebire, “Minimization of drive tests solution in 3GPP,” *Communications Magazine, IEEE*, vol. 50, pp. 28–36, June 2012.
- [114] 3GPP, “3rd Generation Partnership Project; Technical Specification Group Radio Access Network; Universal Terrestrial Radio Access (UTRA) and Evolved Universal Terrestrial Radio Access (E-UTRA); Radio measurement collection for Minimization of Drive Tests (MDT); Overall description; Stage 2 (Release 12),” TS 37.320, 3rd Generation Partnership Project (3GPP), Mar. 2014.
- [115] E. J. Khatib, R. Barco, P. Munoz, I. D. L. Bandera, and I. Serrano, “Self-healing in mobile networks with big data,” *IEEE Communications Magazine*, vol. 54, pp. 114–120, January 2016.
- [116] S. Fan and H. Tian, “Cooperative Resource Allocation for Self-Healing in Small Cell Networks,” *IEEE Communications Letters*, vol. 19, pp. 1221–1224, July 2015.



- [117] J. Qiu, Q. Wu, Y. Xu, Y. Sun, and D. Wu, "Demand-aware resource allocation for ultra-dense small cell networks: an interference-separation clustering-based solution," *Trans. Emerging Telecommunications Technologies*, vol. 27, no. 8, pp. 1071–1086, 2016.
- [118] Y. Liu, X. Li, H. Ji, K. Wang, and H. Zhang, "Joint APs selection and resource allocation for self-healing in ultra dense network," in *2016 International Conference on Computer, Information and Telecommunication Systems (CITS)*, pp. 1–5, July 2016.
- [119] W. Wang, Q. Liao, and Q. Zhang, "COD: A Cooperative Cell Outage Detection Architecture for Self-Organizing Femtocell Networks," *IEEE Transactions on Wireless Communications*, vol. 13, pp. 6007–6014, Nov 2014.
- [120] C. M. Mueller, M. Kaschub, C. Blankenhorn, and S. Wanke, *A Cell Outage Detection Algorithm Using Neighbor Cell List Reports*, pp. 218–229. Berlin, Heidelberg: Springer Berlin Heidelberg, 2008.
- [121] J. Laiho, K. Raivio, P. Lehtimaki, K. Hatonen, and O. Simula, "Advanced analysis methods for 3G cellular networks," *IEEE Transactions on Wireless Communications*, vol. 4, pp. 930–942, May 2005.
- [122] S. Chernov, M. Cochez, and T. Ristaniemi, "Anomaly Detection Algorithms for the Sleeping Cell Detection in LTE Networks," in *2015 IEEE 81st Vehicular Technology Conference (VTC Spring)*, pp. 1–5, May 2015.
- [123] B. Cheung, G. Kumar, and S. A. Rao, "Statistical algorithms in fault detection and prediction: Toward a healthier network," *Bell Labs Technical Journal*, vol. 9, no. 4, pp. 171–185, 2005.
- [124] M. Z. Asghar, R. Fehlmann, and T. Ristaniemi, *Correlation-Based Cell Degradation Detection for Operational Fault Detection in Cellular Wireless Base-Stations*, pp. 83–93. Cham: Springer International Publishing, 2013.
- [125] P. Muñoz, R. Barco, I. Serrano, and A. Gómez-Andrades, "Correlation-Based Time-Series Analysis for Cell Degradation Detection in SON," *IEEE Communications Letters*, vol. 20, pp. 396–399, Feb 2016.
- [126] E. J. Khatib, R. Barco, I. Serrano, and P. Muñoz, "LTE performance data reduction for knowledge acquisition," in *2014 IEEE Globecom Workshops (GC Wkshps)*, pp. 270–274, Dec 2014.
- [127] S. Hou and X. Zhang, "Analysis and Research for Network Management Alarms Correlation Based on Sequence Clustering Algorithm," in *Proceedings of the 2008 International Conference on Intelligent Computation Technology and Automation - Volume 01, ICICTA '08*, (Washington, DC, USA), pp. 982–986, IEEE Computer Society, 2008.



- [128] H. Wietgreffe, “Investigation and practical assessment of alarm correlation methods for the use in GSM access networks,” in *Management Solutions for the New Communications World, 8th IEEE/IFIP Network Operations and Management Symposium, NOMS 2002, Florence, Italy, April 15-19, 2002. Proceedings*, pp. 391–403, 2002.
- [129] A. K. Arhouma and S. M. Amaitik, “Decision Support System for Alarm Correlation in GSM Networks Based on Artificial Neural Networks,” *Conference Papers in Science*, vol. 2013, May 2013.
- [130] Q. K. Al-shayea, “Artificial Neural Networks in Medical Diagnosis,” *International Journal of Computer Science Issues (IJCSI)*, pp. 150–154, 2011.
- [131] B. Krawczyk, D. Simić, S. Simić, and M. Woźniak, “Automatic diagnosis of primary headaches by machine learning methods,” *Central European Journal of Medicine*, vol. 8, no. 2, pp. 157–165, 2013.
- [132] C. Skaanning, “A Knowledge Acquisition Tool for Bayesian-Network Troubleshooters,” *CoRR*, vol. abs/1301.3893, 2013.
- [133] J. Lee, H. Choi, D. Park, Y. Chung, H.-Y. Kim, and S. Yoon, “Fault Detection and Diagnosis of Railway Point Machines by Sound Analysis,” *Sensors*, vol. 16, no. 4/549, 2016.
- [134] Y. Lirov, “Electronic circuit diagnostic expert systems?A survey,” *Computers & Mathematics with Applications*, vol. 18, no. 4, pp. 381 – 398, 1989.
- [135] R. Barco, L. Nielsen, R. Guerrero, G. Hylander, and S. Patel, “Automated troubleshooting of a mobile communication network using Bayesian networks,” in *Mobile and Wireless Communications Network, 2002. 4th International Workshop on*, pp. 606–610, 2002.
- [136] L. Flores-Martos, A. Gomez-Andrades, R. Barco, and I. Serrano, “Unsupervised System for Diagnosis in LTE Networks Using Bayesian Networks,” in *2015 IEEE 81st Vehicular Technology Conference (VTC Spring)*, pp. 1–5, May 2015.
- [137] R. Barco, V. Wille, and L. Díez, “System for automated diagnosis in cellular networks based on performance indicators,” *European Transactions on Telecommunications*, vol. 16, pp. 399–409, sep 2005.
- [138] E. J. Khatib, R. Barco, A. Gómez-Andrades, and I. Serrano, “Diagnosis Based on Genetic Fuzzy Algorithms for LTE Self-Healing,” *IEEE Transactions on Vehicular Technology*, vol. 65, pp. 1639–1651, March 2016.
- [139] A. Gómez-Andrades, P. Muñoz, I. Serrano, and R. Barco, “Automatic Root Cause Analysis for LTE Networks Based on Unsupervised Techniques,” *IEEE Transactions on Vehicular Technology*, vol. 65, pp. 2369–2386, April 2016.



- [140] A. Gómez-Andrades, R. Barco, P. Muñoz, and I. Serrano, “Unsupervised Performance Functions for Wireless Self-Organising Networks,” *Wireless Personal Communications*, vol. 90, no. 4, pp. 2017–2032, 2016.
- [141] J. Cao, L. Li, T. Bu, and S. Sanders, “System and method for root cause analysis of mobile network performance problems,” Oct. 3 2013. WO Patent App. PC-T/US2013/034,027.
- [142] D. Palacios, E. J. Khatib, and R. Barco, “Combination of multiple diagnosis systems in Self-Healing networks,” *Expert Systems with Applications*, vol. 64, pp. 56 – 68, 2016.
- [143] F. Chernogorov, J. Turkka, T. Ristaniemi, and A. Averbuch, “Detection of Sleeping Cells in LTE Networks Using Diffusion Maps,” in *2011 IEEE 73rd Vehicular Technology Conference (VTC Spring)*, pp. 1–5, May 2011.
- [144] F. Chernogorov, T. Ristaniemi, K. Brigatti, and S. Chernov, “N-gram analysis for sleeping cell detection in LTE networks,” in *2013 IEEE International Conference on Acoustics, Speech and Signal Processing*, pp. 4439–4443, May 2013.
- [145] F. Chernogorov and T. Nihtila, “QoS Verification for Minimization of Drive Tests in LTE Networks,” in *2012 IEEE 75th Vehicular Technology Conference (VTC Spring)*, pp. 1–5, May 2012.
- [146] F. Chernogorov and J. Puttonen, “User satisfaction classification for Minimization of Drive Tests QoS verification,” in *2013 IEEE 24th Annual International Symposium on Personal, Indoor, and Mobile Radio Communications (PIMRC)*, pp. 2165–2169, Sept 2013.
- [147] A. Gomez-Andrades, R. Barco, I. Serrano, P. Delgado, P. Caro-Oliver, and P. Munoz, “Automatic root cause analysis based on traces for LTE self-organizing networks,” *IEEE Wireless Communications*, vol. 23, pp. 20–28, June 2016.
- [148] C. Perera, A. Zaslavsky, P. Christen, and D. Georgakopoulos, “Context Aware Computing for The Internet of Things: A Survey,” *IEEE Communications Surveys Tutorials*, vol. 16, pp. 414–454, First 2014.
- [149] C. Baladron, J. Aguiar, B. Carro, L. Calavia, A. Cadenas, and A. Sanchez-Esguevillas, “Framework for intelligent service adaptation to user’s context in next generation networks,” *Communications Magazine, IEEE*, vol. 50, pp. 18–25, March 2012.
- [150] Y. Kawamoto, Z. M. Fadlullah, H. Nishiyama, N. Kato, and M. Toyoshima, “Prospects and challenges of context-aware multimedia content delivery in cooperative satellite and terrestrial networks,” *IEEE Communications Magazine*, vol. 52, pp. 55–61, June 2014.



- [151] S. Wang, Z. Zheng, Z. Wu, Q. Sun, H. Zou, and F. Yang, "Context-aware mobile service adaptation via a Co-evolution eXtended Classifier System in mobile network environments," *Mobile Information Systems*, vol. 10, no. 2, pp. 197–215, 2014.
- [152] 3GPP, "LTE; Study on Context Aware Service Delivery in RAN for LTE," TR 36 933, 3rd Generation Partnership Project (3GPP), Apr. 2017.
- [153] H. Sanneck, Y. Bouwen, and E. Troch, "Context based configuration management of plug & play LTE base stations," in *2010 IEEE Network Operations and Management Symposium - NOMS 2010*, pp. 946–949, April 2010.
- [154] M. Nahas, M. Mjalled, Z. Zohbi, Z. Merhi, and M. Ghantous, "Enhancing LTE - WiFi interoperability using context aware criteria for handover decision," in *Microelectronics (ICM), 2013 25th International Conference on*, pp. 1–4, Dec 2013.
- [155] A. El-Mougy and H. Mouftah, "On resource management and context-awareness in LTE-based networks for Public Safety," in *Local Computer Networks Workshops (LCN Workshops), 2013 IEEE 38th Conference on*, pp. 972–979, Oct 2013.
- [156] I. Mrissa, F. Bellili, S. Affes, and A. Stephenne, "A context-aware cognitive SIMO transceiver for increased LTE-HetNet system-level DL-throughput," in *Wireless Communications and Mobile Computing Conference (IWCMC), 2015 International*, pp. 19–25, Aug 2015.
- [157] S. Hayes, E. Fallon, R. Flynn, and N. Murray, "AMEND - An Algorithm for Mitigating ENvironmental Degradations in heterogeneous networks," in *Consumer Communications and Networking Conference (CCNC), 2015 12th Annual IEEE*, pp. 874–879, Jan 2015.
- [158] E. Woyke, "Microsoft, Motorola, Nokia And RIM To Battle Google Over Indoor Location Market." <http://www.forbes.com/sites/elizabethwoyke/2011/12/22/microsoft-motorola-nokia-and-rim-to-battle-google-over-indoor-location-market/>, Dec. 2011. Accessed: 2017-03-01.
- [159] M. Molina-García, J. Calle-Sánchez, J. I. Alonso, A. Fernández-Durán, and F. B. Barba, "Enhanced In-Building Fingerprint Positioning Using Femtocell Networks," *Bell Labs Technical Journal*, vol. 18, no. 2, pp. 195–211, 2013.
- [160] A. Narzullaev, Y. Park, K. Yoo, and J. Yu, "A fast and accurate calibration algorithm for real-time locating systems based on the received signal strength indication," *AEUE - International Journal of Electronics and Communications*, vol. 65, no. 4, pp. 305–311, 2011.
- [161] Indoo.rs, "Indoo.rs - webpage." <https://indoo.rs>. Accessed: 2017-03-01.
- [162] Wifarer, "Wifarer - webpage." <http://www.wifarer.com/>. Accessed: 2017-03-01.
- [163] infsoft, "infsoft - webpage." <https://www.infsoft.com/>. Accessed: 2017-03-01.



- [164] K. Bouchard, D. Fortin-Simard, S. Gaboury, B. Bouchard, and A. Bouzouane, “Accurate Trilateration for Passive RFID Localization in Smart Homes,” *International Journal of Wireless Information Networks*, vol. 21, no. 1, pp. 32–47, 2014.
- [165] B. Ozdenizci, K. Ok, V. Coskun, and M. N. Aydin, “Development of an Indoor Navigation System Using NFC Technology,” in *2011 Fourth International Conference on Information and Computing*, pp. 11–14, April 2011.
- [166] M. Raitoharju, H. Nurminen, and R. Piché, “Kalman filter with a linear state model for PDR+WLAN positioning and its application to assisting a particle filter,” *EURASIP Journal on Advances in Signal Processing*, vol. 2015, no. 1, pp. 1–13, 2015.
- [167] P. Müller, H. Wymeersch, and R. Piché, “UWB Positioning with Generalized Gaussian Mixture Filters,” *IEEE Transactions on Mobile Computing*, vol. 13, pp. 2406–2414, Oct 2014.
- [168] T. Perry, “The Indoor Navigation Battle Heats Up.” <http://spectrum.ieee.org/tech-talk/consumer-electronics/portable-devices/the-indoor-navigation-battle-heats-up>, Aug. 2012. Accessed: 2017-03-01.
- [169] P. Zhang, J. Lu, Y. Wang, and Q. Wang, “Cooperative localization in 5G networks: A survey,” *{ICT} Express*, vol. 3, no. 1, pp. 27 – 32, 2017.
- [170] M. Koivisto, M. Costa, J. Werner, K. Heiska, J. Talvitie, K. Leppänen, V. Koivunen, and M. Valkama, “Joint Device Positioning and Clock Synchronization in 5G Ultra-Dense Networks,” *IEEE Transactions on Wireless Communications*, vol. 16, pp. 2866–2881, May 2017.
- [171] 3GPP, “LTE; Scenarios and requirements for small cell enhancements for E-UTRA and E-UTRAN,” TR 36.932, 3rd Generation Partnership Project (3GPP), Apr. 2017.
- [172] X. Ge, S. Tu, G. Mao, C. X. Wang, and T. Han, “5G Ultra-Dense Cellular Networks,” *IEEE Wireless Communications*, vol. 23, pp. 72–79, February 2016.
- [173] 3GPP, “LTE; Evolved Universal Terrestrial Radio Access (E-UTRA); Physical layer; Measurements,” TS 36.214, 3rd Generation Partnership Project (3GPP), Jan. 2017.
- [174] 3GPP, “3rd Generation Partnership Project; Technical Specification Group Radio Access Network; Physical layer; Measurements (FDD) (Release 13),” TS 25.215, 3rd Generation Partnership Project (3GPP), Dec. 2015.
- [175] I. Narsky and F. C. Porter, *Density Estimation*, ch. 5, pp. 89–120. Wiley-VCH Verlag GmbH and Co. KGaA, 2013.



- [176] 3GPP, “Telecommunication management; Home enhanced Node B (HeNB) Operations, Administration, Maintenance and Provisioning (OAM&P); Procedure flows for Type 1 interface HeNB to HeNB Management System (HeMS),” TS 32.593, 3rd Generation Partnership Project (3GPP), Jan. 2015.
- [177] 3GPP, “3rd Generation Partnership Project; Technical Specification Group Services and System Aspects; Local IP Access and Selected IP Traffic Offload (LIPA-SIPTO) (Release 10),” TR 23.829, 3rd Generation Partnership Project (3GPP), Oct. 2011.
- [178] J. M. Ruiz-Aviles, S. Luna-Ramirez, M. Toril, and F. Ruiz, “Fuzzy Logic Controllers for Traffic Sharing in Enterprise LTE Femtocells,” in *Vehicular Technology Conference (VTC Spring), 2012 IEEE 75th*, pp. 1–5, May 2012.
- [179] T. Takagi and M. Sugeno, “Fuzzy identification of systems and its applications to modeling and control,” *IEEE Transactions on Systems, Man, and Cybernetics*, vol. SMC-15, pp. 116–132, Jan 1985.
- [180] NGNM, “Small Cell Backhaul Requirements,” Whitepaper 1.0, Next Generation Mobile Networks Alliance, June 2012.
- [181] R. Barco, V. Wille, and L. Díez, “System for automated diagnosis in cellular networks based on performance indicators,” *European Transactions on Telecommunications*, vol. 16, no. 5, pp. 399–409, 2005.
- [182] R. Barco, P. Lázaro, V. Wille, L. Díez, and S. Patel, “Knowledge Acquisition for Diagnosis Model in Wireless Networks,” *Expert Syst. Appl.*, vol. 36, pp. 4745–4752, Apr. 2009.
- [183] 3GPP, “Radio Resource Control (RRC); Protocol specification,” TS 23.331, 3rd Generation Partnership Project (3GPP), Mar. 2016.
- [184] K. Al Nuaimi and H. Kamel, “A survey of indoor positioning systems and algorithms,” in *Innovations in Information Technology (IIT), 2011 International Conference on*, pp. 185–190, IEEE, 2011.
- [185] R. M. Groves, F. J. Fowler, Jr., M. P. Couper, J. M. Lepkowski, E. Singer, and R. Tourangeau, *Survey Methodology*. Wiley Series in Survey Methodology, Hoboken, N.J.: John Wiley & Sons, second ed., 2009.
- [186] H. Zhang, “The Optimality of Naive Bayes,” in *FLAIRS Conference* (V. Barr and Z. Markov, eds.), pp. 562–567, AAAI Press, 2004.
- [187] F. Aurenhammer, “Power Diagrams: Properties, Algorithms and Applications,” *SIAM J. Comput.*, vol. 16, pp. 78–96, Feb. 1987.
- [188] P. Kyösti, J. Meinilä, L. Hentilä, X. Zhao, T. Jämsä, C. Schneider, M. Narandzić, M. Milojević, A. Hong, J. Ylitalo, V.-M. Holappa, M. Alatossava, R. Bultitude, Y. de Jong, and T. Rautiainen, “WINNER II Channel Models,” tech. rep., EC FP6, Sept. 2007.



- [189] W. P. Gajewski, “Adaptive Naive Bayesian Anti-Spam Engine,” *Int. J. Inf. Technol.*, vol. 3, pp. 153–159. 7 p, May 2006.
- [190] K. Hormann and A. Agathos, “The Point in Polygon Problem for Arbitrary Polygons,” *Comput. Geom. Theory Appl.*, vol. 20, pp. 131–144, Nov. 2001.
- [191] K. A. Brakke, “Statistics of random plane Voronoi tessellations,” *Department of Mathematical Sciences, Susquehanna University (Manuscript 1987a)*, 1987.
- [192] 3GPP, “Universal Mobile Telecommunications System (UMTS); Physical layer procedures (FDD) (3GPP TS 25.214 version 12.0.0 Release 12),” TS 25.214, 3rd Generation Partnership Project (3GPP), Sept. 2014.
- [193] S. Novaczki and P. Szilagyi, “Radio Channel Degradation Detection and Diagnosis Based on Statistical Analysis,” in *Vehicular Technology Conference (VTC Spring), 2011 IEEE 73rd*, pp. 1–2, May 2011.
- [194] M. Dakkak, A. Nakib, B. Daachi, P. Siarry, and J. Lemoine, “Indoor localization method based on RTT and AOA using coordinates clustering,” *Computer Networks*, vol. 55, no. 8, pp. 1794 – 1803, 2011.
- [195] R. S. Campos, L. Lovisolo, and M. L. R. de Campos, “Wi-Fi multi-floor indoor positioning considering architectural aspects and controlled computational complexity,” *Expert Systems with Applications*, vol. 41, no. 14, pp. 6211 – 6223, 2014.
- [196] M. Stella, M. Russo, and D. Begušić, “Fingerprinting based localization in heterogeneous wireless networks,” *Expert Systems with Applications*, vol. 41, no. 15, pp. 6738 – 6747, 2014.
- [197] Gyokov Solutions, “G-NetTrack phone measurement capabilities - webpage.” <http://www.gyokovsolutions.com/survey/surveyresults.php>. Accessed: 2017-03-01.
- [198] Ericsson, “App Experience Optimization - webpage.” <http://www.ericsson.com/ourportfolio/services/app-experience>. Accessed: 2017-03-01.
- [199] E. Langford, “Quartiles in Elementary Statistics,” *Journal of Statistics Education*, vol. 14, Nov. 2006.
- [200] T. Bai and R. W. Heath, “Location-specific coverage in heterogeneous networks,” *IEEE Signal Processing Letters*, vol. 20, no. 9, pp. 873–876, 2013.
- [201] A. W. Bowman and A. Azzalini, *Applied Smoothing Techniques for Data Analysis: The Kernel Approach with S-Plus Illustrations*, pp. 427–445. Oxford University Press Inc., UK, 1997.
- [202] 3GPP, “LTE; Evolved Universal Terrestrial Radio Access (E-UTRA); Requirements for support of radio resource management,” TS 36.133, 3rd Generation Partnership Project (3GPP), Sept. 2014.



- [203] W. P. Gajewski, “Adaptive Naïve Bayesian Anti-Spam Engine,” *International Journal of Mathematical, Computational, Physical, Electrical and Computer Engineering*, vol. 1, no. 7, pp. 318 – 323, 2007.
- [204] C. H. Lee, F. Gutierrez, and D. Dou, “Calculating Feature Weights in Naive Bayes with Kullback-Leibler Measure,” in *2011 IEEE 11th International Conference on Data Mining*, pp. 1146–1151, Dec 2011.
- [205] M. N. (originator), “Hellinger distance,” in *Encyclopedia of Mathematics*, Springer, 2011. [https://www.encyclopediaofmath.org/index.php/Hellinger\\_distance](https://www.encyclopediaofmath.org/index.php/Hellinger_distance). Accessed: 2017-03-01.
- [206] N.-L. Tran, Q. Dugauthier, and S. Skhiri, “A Distributed Data Mining Framework Accelerated with Graphics Processing Units,” *2013 International Conference on Cloud Computing and Big Data (CloudCom-Asia)*, vol. 00, pp. 366–372, 2013.
- [207] H. T, W. H, and K. M, *Progress in Location-Based Services*. Berlin, Heidelberg: Springer-Verlag Berlin Heidelberg, 2013.
- [208] D. Yang, H. Li, Z. Zhang, and G. D. Peterson, “Compressive Sensing Based Submm Accuracy UWB Positioning Systems: A Space-time Approach,” *Digit. Signal Process.*, vol. 23, pp. 340–354, Jan. 2013.
- [209] M. Pablo, d. l. B. Isabel, R. Fernando, L.-R. Salvador, B. Raquel, T. Matías, L. Pedro, and R. Jaime, “Computationally-Efficient Design of a Dynamic System-Level LTE Simulator,” *International Journal of Electronics and Telecommunications*, vol. 57, p. 347, sep 2011.
- [210] T. B. Sorensen, P. E. Mogensen, and F. Frederiksen, “Extension of the ITU channel models for wideband (OFDM) systems,” in *VTC-2005-Fall. 2005 IEEE 62nd Vehicular Technology Conference, 2005.*, vol. 1, pp. 392–396, Sept 2005.
- [211] C. Bettstetter, G. Resta, and P. Santi, “The node distribution of the random waypoint mobility model for wireless ad hoc networks,” *IEEE Transactions on Mobile Computing*, vol. 2, pp. 257–269, July 2003.
- [212] Wikipedia, “List of the busiest airports in Europe — Wikipedia, The Free Encyclopedia,” 2004. [Online; accessed 2017-03-01].
- [213] “Small Cell Forum - Deployment stories.” <http://www.smallcellforum.org/resources/deployment-stories/>. Accessed: 2017-03-01.
- [214] P. Description, “Alcatel-Lucent 9365 Base Station Router Femto,” *Legacy*, pp. 1–19, 2009.
- [215] C. Garcia-Rubio, “Mobile Network-Based Fingerprinting Localization using Android smartphones,” in *Workshop sobre localización en interiores con small cells. Conclusiones del proyecto MONOLOC*, Alcatel-Lucent, Nov 2014. Accessed: 2017-03-01.



- [216] A. Roxin, J. Gaber, M. Wack, and A. Nait-Sidi-Moh, “Survey of Wireless Geolocation Techniques,” in *2007 IEEE Globecom Workshops*, pp. 1–9, Nov 2007.



UNIVERSIDAD  
DE MÁLAGA



UNIVERSIDAD  
DE MÁLAGA