

Tactile Handle for an Instrumented Cane

Andrés Trujillo-León, Fernando Vidal-Verdú
Departamento de Electrónica, Universidad de Málaga
Instituto de Investigación Biomédica de Málaga (IBIMA)
Málaga, Spain
{atrujilloleon, fvidal}@uma.es

Ragou Ady, Wael Bachta
Sorbonne Universités, UPMC Univ. Paris 06
CNRS UMR7222, INSERM U1150
Paris, France
{ragou.ady, wael.bachta}@upmc.fr

Abstract—Tactile sensors are useful input devices to implement human machine interfaces in areas such as rehabilitation or assistance. They can prevent damage from accidents or bad usage, and also provide rich information to infer human behavior from the pressure distribution at the contact interface. This paper introduces an instrumented cane handle equipped with a tactile sensor. The electronics devoted to data acquisition, pre-processing and communication is described. Furthermore, results from tests with different users are shown to illustrate how the information provided by the tactile sensor is related to the gait and can be exploited for research or as control input in an active cane.

Keywords—tactile sensors; rehabilitation; gait assistance.

I. INTRODUCTION

Population aging is a major concern in Western Societies. The increase in life expectancy and the low birth rate make that average age increases. Societies get older and this is changing the way of living [1]. Moreover, challenges arise to extend the autonomy of people as much as possible. This is mandatory since there will not be enough young people to take care of the elder, and it is obviously desirable to increase the quality of life and self-esteem. Besides of progresses in medicine that will heal and preserve our bodies, robotics and smart systems can be a great source of assistive devices that provide solutions to the new needs. Assistive robots or devices should be designed with a first restriction in mind: safety. Human robot interaction is a broader field of interest and research that shares this concern.

Tactile sensors or artificial skins have implemented a way to protect humans against accidental damage caused by machines, and they are also a mean to implement interaction between robots and humans. However, tactile sensors can play a more advanced role in implementing a human-assistive device interface. This can be done by taking advantage of the fact that tactile sensors are arrays and they provide information not only from the aggregated output but also from its spatial distribution [2]. This is done in manipulation with robotic hands or grippers, where the tactile moments are computed to obtain information like contact size and shape, or contact location [3]. Similar information from the contact between the human and the machine can be exploited to build the interface. For instance, tactile information is used in [4] to implement a device that aims a natural and intuitive driving of a wheelchair or trolley. Another assistive device that targets the issue of mobility in old populations is an active or smart cane [5]. It is preferable to a wheelchair as long as possible, since the user keeps more active. Tactile sensors can be used in this context in two senses. First, they are a mean to obtain knowledge

about the force distribution on the handle, so they can provide information about how the cane contributes to the balance in the gait process. Second, similarly to the usage pointed out in [4], they can work as an interface to infer the user intention and help to design intuitive and friendly assistive canes.

This paper intends to show that it is certainly possible to get useful information for these purposes from a tactile sensor. Specifically, a simple tactile sensor was built with an array of commercial force sensing resistors [6]. Then, it is exploited to find which relevant data can be extracted during its use as a cane handle. The obtained results confirm that the sensor provides information about two basic parameters involved in the gait process: the load force on the cane when the user leans on it and the orientation of the cane shaft. Therefore, the potential use of tactile sensors in these assistive devices, as for example the instrumented cane shown in [7], is proved.

The structure of this paper is the following. In Section II, the developed device is introduced. Firstly, the tactile handle is described. Then the electronics conditioning for the latter is covered. In Section III, the experiments, the materials involved in them as well as the analysis of the extracted data are detailed. Section IV is dedicated to present and discuss the obtained results. Finally, the paper is closed with Section V in which the conclusions of this work are exposed.

II. DEVELOPED DEVICE

This section describes the device this document focuses on. Firstly, an introduction of the design of the tactile handle is given. Secondly, the hardware in charge of the sensor acquisition is described in detail.

A. Tactile handle

The shape of the developed handle intends to emulate a 'T' cane handgrip. This kind of handles is specially suitable for people who have suffered a loss of strength in their hand. Figure 1 shows the physical implementation of the handle. Commercial force sensing resistor (FSR) sensors from Interlink Electronics [6] have been chosen as tactile sensing units. Their output is less linear and sensitive if the sensors are placed on a rough surface. Therefore, in order to have a good performance, they must lie on a flat surface [8]. This constraint explains the square profile of the handle. Five FSR sensors have been placed on the upper, left and right faces of the handle. Only three sensors have fitted in the lower side since it is where the cane shaft and the handle join. The eighteen tactels have been interconnected forming a matrix of four rows by five columns (Figure 2). Note that in the lower face, the number of columns is reduced to three. The matrix configuration is



Figure 1. Tactile handle implementation.

optimal since it minimizes the resources needed to address and digitize the tactels.

Moreover, soft pads have been placed on the active area of the FSR sensors to enhance the response by concentrating the force. Finally, the whole structure is covered with a layer of foam to make the grasp more comfortable.

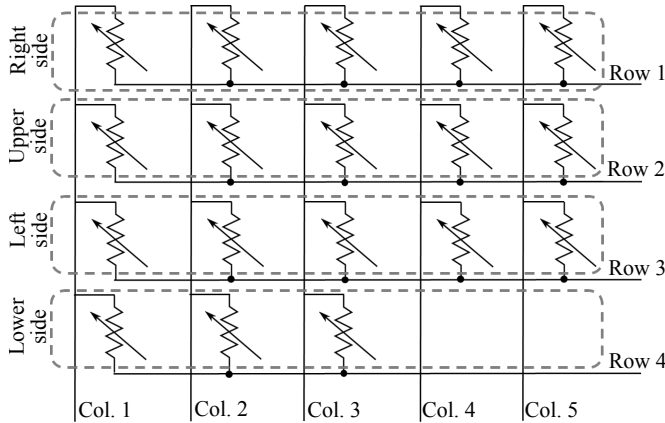

Figure 2. Matrix of FSR sensors schematics.

B. Conditioning electronics

The acquisition board (Figure 4) is based on a PIC18F4680 from Microchip Electronics. This microcontroller possesses a wide range of input/output interfaces and a considerable number of Analog-to-Digital (A/D) channels at an affordable price. Figure 3 shows the circuit scheme. The columns of the FSR matrix are wired to the A/D channels of the microcontroller through a trans-impedance stage. On the other hand, the rows are connected to analog switches controlled by generic digital input/output ports of the PIC. These activate the switches in order to ground the row that is going to be read and to connect the others to a reference voltage (V_{ref}). Note that the output of the amplifier for the chosen tactel can be calculated as shown:

$$V_{out_{i,j}} = V_{ref} \left(1 + \frac{R_G}{R_{S_{i,j}}} \right) \quad (1)$$

Where $R_{S_{i,j}}$ the resistance of the FSR sensor in (i, j) position.

Besides, the feedback resistance R_G is implemented with a potentiometer so the gain of every column can be tuned independently. The output for the rest of the tactels will be zero as the voltages in the amplifier inputs are the same, V_{ref} , due to the negative feedback. This way, $V_{out_{i,j}} \in [V_{ref}, V_{DD}]$ being V_{DD} the supply voltage (the amplifiers saturation voltage, actually). Note that V_{ref} should be a low value in order to have a good dynamic range.

Once the voltage given by (1) has been digitized for every tactel, the information is ready to be sent to other devices through the communication interfaces. In the experiment that will be described in this paper, the tactile handle readings are sent to a computer using a serial-to-USB converter. Nevertheless, they can be also transmitted through the I^2C bus with a level conversion in case the board is embedded, for example, in an active cane as the one described in [5].

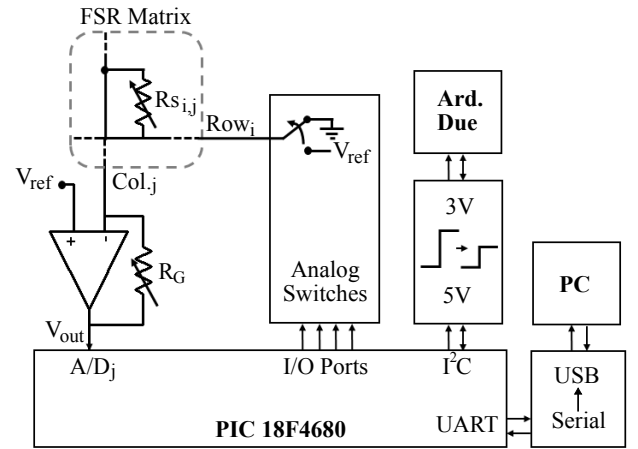

Figure 3. Conditioning electronics scheme.

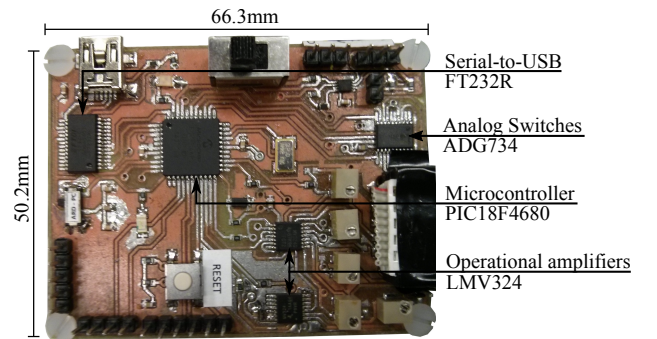

Figure 4. Conditioning electronics board.

III. MATERIALS AND METHODS

This section introduces the experimental setup. Furthermore, the protocol followed to carry out the experiments and the parameters under analysis are described.

A. Experimental setup

In order to test the device introduced in the previous section, an experimental setup was built (Figure 6). In addition

to the tactile handle, two more sensors are used. Firstly, an inertial module unit (IMU) measures the yaw angle in the walking direction, that is to say, the angle with respect to the vertical in the sagittal plane. An Arduino Due board gathers the data from the IMU. Secondly, a Mini45 Force/Torque sensor, from ATI Industrial Automation, obtains the load force in the cane shaft axis (F_z). The acquisition card that processes the data from the Mini45 is the National Instruments USB-6211.

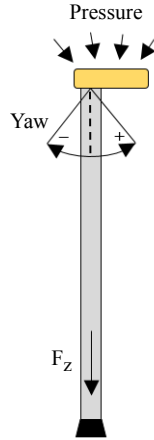

Figure 5. Parameters captured during the experiments.

The tactile handle acquisition board, the Arduino Due and the USB-6211 are connected to a computer through an USB hub. The computer synchronizes the capture of the three sensors at a rate of 40Hz.

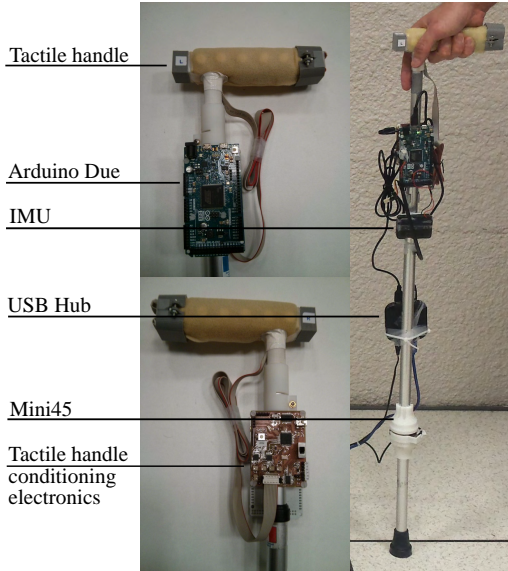

Figure 6. Experimental setup.

B. Experiments and analysis

Ten healthy subjects aged between 21 and 32 took part in the tests. They wore a brace in one of their legs and a modified sole in order to simulate walking impairment [9]. They were naive about the experiment purpose. They were asked to use

the cane walking straight for 5.5m. Every subject repeated the test four times.

As it was introduced in the previous section, the parameters from the external sensors that have been analyzed are F_z and the yaw angle (Figure 5). With respect to the tactile handle, the pressure map (Figure 7) can be processed in several ways. One of them consist in obtaining the center of mass (CoM) of the tactile image. This parameter can be calculated either taking into account the whole FSR matrix or just considering the rows one by one. In the latter case, the CoM of one side of the tactile handle is determined by (2).

$$CoM_{side} = \frac{\sum_{i=1}^5 p(i) \times x(i)}{\sum_1^5 p(i)} \quad (2)$$

Where $p(i)$ and $x(i)$ are the position and the pressure value of the i^{th} tactel in the handle side, respectively.

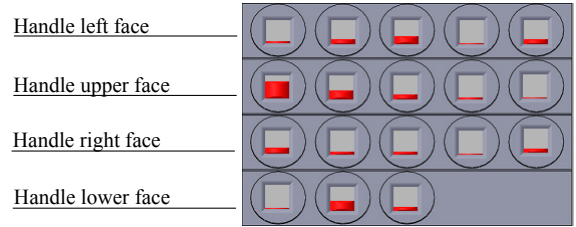

Figure 7. Example of pressure map from the tactile handle.

On the other hand, the tactile handle can also provide information about the grip pressure. Again, this can be estimated either in a global way, that is to say, including all the tactels or considering each row separately. Thus, the component of the grip pressure in one row of the FSR matrix could be calculated as the mean pressure on that side of the handle:

$$\bar{P}_{side} = \frac{\sum_{i=1}^5 p(i)}{5} \quad (3)$$

In the analysis carried out in this paper, the parameters in (2) and (3) have been estimated for the upper side of the handle (Figure 1 and 7). Furthermore, in order to remove the noise, all the data have been low-pass filtered.

IV. RESULTS AND DISCUSSION

To assess the associations between, on the one hand, the CoM_u and F_z and, on the other hand, the \bar{P}_u and the cane yaw angle, Pearson correlation coefficients are computed for each subject using the mean trajectories across the four trials. All the coefficients are close to 1 with a statistical significance. This states a strong linear correlation between the observed parameters.

Looking at the results of the experiments presented in Figure 8, it can be indeed observed that the yaw angle and the center of mass of the upper side of the handle (CoM_u) are strongly coupled. The figure shows the mean of these parameters for the four test performed by one the subjects. This subject can be considered representative of the results obtained in the experiments. Note that CoM_u has been amplified and

shifted vertically to ease the visual comparison. This way, CoM_u unit (mm) and scale must be ignored since they have been altered. In addition, computing the tests mean requires that all of them have the same number of samples. Thus, they have been interpolated and, consequently, the time scale deformed. That is the reason why there are no values in the time axis. Lastly, the first and last step have been removed since they are a transient component and are not relevant in the analysis of the steady gait.

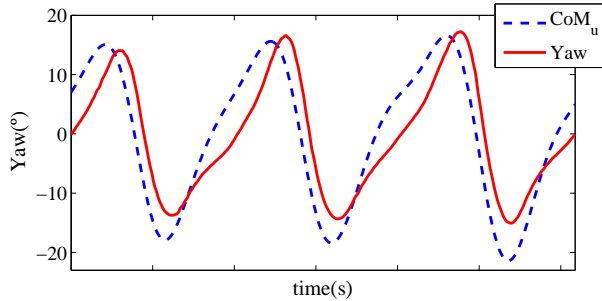

Figure 8. Yaw and CoM_u for a representative subject.

The same happens if we look at the pair formed by F_z and \bar{P}_u . Figure 9 shows the mean of these parameters for all the tests carried out by the same subject as before. \bar{P}_u has been pre-processed in the same way as CoM_u to make the graphic comparison easier.

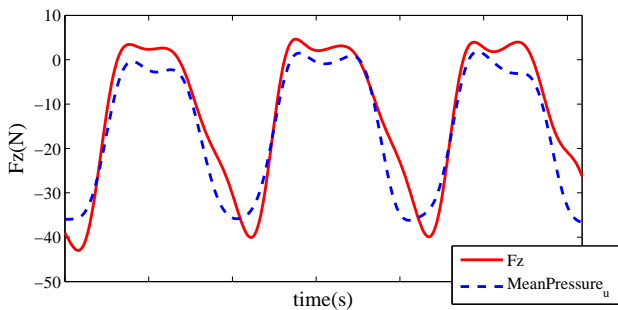

Figure 9. F_z and \bar{P}_u for a representative subject. Note that the same as in Figure 8 happens with time axis and, in this occasion, with the \bar{P}_u unit (V) and scale.

The pattern in the latter figures repeats for every subject in the experiments to a greater or lesser extent. Therefore, it is certainly feasible to reach an estimation of the angle of the orientation of the cane and the load force exerted on it based on the data acquired by the tactile handle presented in Section II.

V. CONCLUSIONS

A device composed of a tactile handle and its conditioning electronics has been presented. Experiments have been realized in order to test it. According to the results analyzed in Section IV, a tight coupling between two parameters involved in the gait process and two parameters extracted from the tactile handle has been found. These are, on the one hand, the load force applied on the cane and the mean pressure on the upper part of the handle and, on the other hand, the angle of the

orientation of the cane shaft and the center of mass of the upper side of the handle.

The preliminary results show the operation and viability of the tactile handle as a tool to monitor the assisted gait as well as a sensor device in a smart or robotic active cane.

Future work could involve the implementation of a second prototype with a miniaturised conditioning electronics. In it, the data could be either transmitted by a wireless protocol as Bluetooth or stored locally. Thus, wires would no longer be necessary and the system would be more comfortable to use. Another possible point to address could be the realization of a more ergonomic handle. Finally, apart from the variables shown in this work, the coupling between other parameters could be studied.

ACKNOWLEDGMENT

This work was partly accomplished within the laboratory of excellence SMART supported by French state funds managed by the ANR within the Investissements d'Avenir programme ANR-11-IDEX-0004-02. It has been also partially funded by the Spanish Government under contract TEC2012-38653, FPU Program and European ERDF funds.

REFERENCES

- [1] "Demographic change and work in Europe," 2010, URL: http://www.eurofound.europa.eu/sites/default/files/ef_files/ewco/surveyreports/EU0902019D/EU0902019D.pdf [accessed: MAY, 2015].
- [2] R. Dahiya, P. Mittendorfer, M. Valle, G. Cheng, and V. Lumelsky, "Directions Toward Effective Utilization of Tactile Skin: A Review," *Sensors Journal, IEEE*, vol. 13, 2013, pp. 4121–4138, ISSN: 1530-437X.
- [3] A. Schmid, N. Gorges, D. Goger, and H. Worn, "Opening a door with a humanoid robot using multi-sensory tactile feedback," in *Robotics and Automation, 2008. ICRA 2008. IEEE International Conference on*, May 2008, pp. 285–291.
- [4] A. Trujillo-León and F. Vidal-Verdú, "Driving Interface Based on Tactile Sensors for Electric Wheelchairs or Trolleys," *Sensors*, vol. 14(2), 2014, pp. 2644–2662, ISSN: 1424-8220.
- [5] R. Ady, W. Bachta, and P. Bidaud, "Development and control of a one-wheel telescopic active cane," in *Biomedical Robotics and Biomechanics (2014 5th IEEE RAS EMBS International Conference on*, Aug. 2014, pp. 461–466.
- [6] "Interlink Electronics. FSR402®," 2011, URL: <http://www.interlinkelectronics.com/FSR402.php> [accessed: JUNE, 2015].
- [7] C. Perez, A. Oates, L. Hughey, and J. Fung, "Development of a force-sensing cane instrumented within a treadmill-based virtual reality locomotor system," in *Virtual Rehabilitation International Conference*, 2009, June 2009, pp. 154–159.
- [8] F. Vidal-Verdú, M. Barquero, J. Castellanos-Ramos, R. Navas-González, J. Sánchez, J. Serón, and A. García-Cerezo, "Large Area Tactile Sensor Patch Based on Commercial Force Sensors," *Sensors*, vol. 11(5), 2011, pp. 5489–5507, ISSN: 1424-8220.
- [9] M. Ackermann and W. Schiehlen, "Dynamic Analysis of Human Gait Disorder and Metabolical Cost Estimation," *Archive of Applied Mechanics*, vol. 75, 2006, pp. 569–594, ISSN: 0939-1533.