

Optimal Microgrid Operation with Electric Vehicles

M. A. López, *Student Member, IEEE*, S. Martín, *Student Member, IEEE*,
J. A. Aguado, *Member, IEEE* and S. de la Torre, *Member, IEEE*

Abstract—The concern about the complete depletion of fossil fuels along with the negative environmental impact of most of the current energy sources are significant reasons to think of a different way to produce electrical energy and, at the same time, satisfy the necessities for urban mobility. In this context, microgrids (MGs) are power networks which, among other properties, allow a more flexible demand consumption, and also help with, the efficient integration of renewable resources and electric vehicles (EVs). However, the effect of the incorporation of EVs has to be taken into consideration with care, since that situation may drive to unfeasible operations in grids which have not been designed to support these particular elements. In this paper, a system composed of different agents is used to develop a market-oriented operation in a MG with several EV charge stations. It is expected that the system takes to an optimal management allowing a technically feasible operation considering the behaviour of every agent involved. The demand shifting and the flexible operation of EVs, spatial and temporal, are features that reduce costs and thus improve the benefit of the participants.

Index Terms—Electric vehicles, renewable resources, energy storage, optimal power flow, microgrids, price responsive demand

I. NOMENCLATURE

A. Indexes

t time periods (hours), $t = 1, 2, \dots, 24$;
 i generators, $i = 1, 2, \dots, 8$;
 v electric vehicles, $v = 1, 2, 3$;
 j agents, $j = 1, 2, \dots, 7$;
 n nodes, $n = 1, 2, \dots, 17$;
 m alias for nodes, $m = 1, 2, \dots, 17$.
 k microgrid element (non-renewable generator, renewable generator or main grid), $k = 1, 2, 3$.

The uppercase letter for each index represents the higher value of that index.

B. Parameters

λ_t^s main grid hourly selling price to the microgrid (€/MWh);

λ_t^b main grid hourly buying price to the microgrid (€/MWh);
 $S_{v,j}^{max}$ upper limit for the energy level for battery of the EV v , belonging to agent j (kWh);
 $S_{v,j}^{min}$ lower limit for the energy level for battery of the EV v , belonging to agent j (kWh);
 $S_{t,v,j}^{sch}$ scheduled energy level for battery of EV v belonging to agent j in period t (kWh);
 $P_{v,n}^{max}$ upper limit for the power flow in node n for battery of the EV v (kW);
 $P_{v,n}^{min}$ lower limit for the power flow in node n for battery of the EV v (kW);
 $P_{g,i,j}^{max}$ upper limit for active power output for generator i belonging to agent j (kW);
 $P_{g,i,j}^{min}$ lower limit for active power output for generator i belonging to agent j (kW);
 $Q_{g,i,j}^{max}$ upper limit for reactive power output for generator i belonging to agent j (kVAr);
 $Q_{g,i,j}^{min}$ lower limit for reactive power output for generator i belonging to agent j (kVAr);
 S_{nm}^{max} upper limit for the apparent power for the line that connects buses n and m (kVA);
 G_{nm} conductance of the line that connects buses n and m ;
 B_{nm} susceptance of the line that connects buses n and m ;
 η_{Cv} charge efficiency for battery of the EV v ;
 η_{Dv} discharge efficiency for battery of the EV v ;
 t_f final simulation period of time considered;
 t_{full} full charge period of time for EVs.

C. Positive Variables

$P_{t,j}^B$ Energy that agent j is willing to buy in period t (kWh);
 $P_{t,j}^S$ energy that agent j is willing to sell in period t (kWh);
 $P_{t,v,j}^{c,n}$ charge energy for electric vehicle v belonging to agent j in node n and period t (kWh);
 $P_{t,v,j}^{d,n}$ discharge energy for electric vehicle v belonging to agent j in node n and period t (kWh);
 $P_{i,j}^G$ active power output for generator i belonging to agent j (kW);
 $Q_{i,j}^G$ reactive power output for generator i belonging to

M. A. López, S. Martín, J. A. Aguado and S. de la Torre are with the Department of Electrical Engineering, University of Málaga, Spain (e-mail: malopezperez@uma.es, smartin@uma.es, jaguado@uma.es, storre@uma.es).

The work reported in this paper was supported in part by the Ministry of Science and Innovation of Spain Grant ENE2011-27409 and by Junta de Andalucía Proyectos de excelencia TEP-4210.

	agent j (kVAr);
V_n	voltage of node n (V);
θ_n	angle of node n (rad);
θ_{nm}	difference between the angle of nodes n and m (rad);
P_k^f	final power from OPF for element k (kW);
P_k^i	initial power from agent's optimization problems for element k (kW);
$S_{t,v,j}^b$	energy level for battery of EV v belonging to agent j in period t (kWh).

D. Free Variables

P_{nm}	active power flow leaving bus n to bus m ;
Q_{nm}	reactive power flow leaving bus n to bus m .

II. INTRODUCTION

AT the present time, it is undeniable that there exists an increasing concern about the future of traditional ways to produce electrical energy. On the one hand, many generation plants rely on fossil fuels or other non-renewable energy sources which have a negative effect on the environment. On this matter, some observers highlight the necessity of smart technologies able to track and manage energy use patterns, to provide flexible power that follows demand through the day and to use better storage options, in order to secure the renewable energy future. On the other hand, generators are often far from the areas in which energy is consumed what results in higher transmission costs derived from losses and less reliability. These inconveniences can be partially avoided through a new trend of power networks, i.e. MicroGrids (MGs), which facilitate the integration of renewable sources and permit a more reliable electrical grid [1], [2]. Furthermore, MGs are suitable to house charging stations for Electric Vehicles (EVs) and, at the same time, enable market operations with the main grid [3], [4].

III. BACKGROUND AND DESCRIPTION

MGs are electric power networks containing small Distributed Energy Resources (DERs) and different end-users connected to each other by electric lines. These networks usually have storage devices scattered over them and they are expected to host electric and hybrid vehicles charging stations. It is also expected that MGs improve energy use, reduce losses in transportation, provide reliability in the whole system and enable the integration of renewable resources [1]. A MG can work either in islanded mode or relying on the main distribution grid.

We can encounter several control and operational issues depending on the particular characteristics of the MG. For instance, voltage and frequency control and active/reactive power control are particular operations that have to be used for safety and stability of the complete network and they are important to make market transactions possible. Other MG tasks are power and energy management, economic dispatch, load flow and renewable resources handling. The whole set of

tasks can be carried out through either a centralized or a decentralized control [1]. Because of generators, loads, storage units and vehicles have normally different owners and there are several decisions to be taken locally, centralized control, although possible, becomes difficult. Local operators have autonomy, intelligence and can communicate between them in order to achieve an overall objective in the MG.

Some authors have worked in how to solve operation and control issues in MGs using Multi-Agent Systems [5]-[7]. In [2], the implementation of distributed controls for a typical energy market operation is presented using intelligent agents via an evolutionary approach. In this work, a market-oriented operation supported in a technical arrangement is proposed. The MG taken as reference is described in [8]. The market operation takes into account an internal specific auction among the different agents belonging to the MG and a possible energy transaction between the MG and the main distribution grid. A generic agent with load demands, generators (both renewable and traditional), batteries and EVs, is defined, covering, this way, any possible real situation. The auctioneer handles all the information and delivers the energy to each agent according to the established rules.

The whole system is supported on an optimal load flow to facilitate the feasibility of the market operation. For this purpose, a specific technical agent has been proposed. This agent carries out an optimal power flow to take the grid to another operation point trying to minimize the difference between the final situation and the initial one with respect to the energy supplied by generators. In any case, an optimal and feasible situation is pursued.

Additionally, it can be said that the introduction of EVs inside electric power networks, and in particular for MGs, will cause a remarkable change in the way we work and think about such systems. EVs can behave as an electric shifting demand but it is also possible for them to act as generators, giving them the possibility of participating as a seller in the market [4]. Therefore, there is a need to develop new tools to facilitate the operation and control of these potential elements. Different methods have been proposed to study the effect of the incorporation of EVs into future networks. In [9], coordinated charging of EVs is computed by minimizing power losses on the grid considering stochastic programming and evaluating voltage deviations. Additional load costs are calculated in [10] to establish a charging scheme that minimizes these costs. The impact of large penetration of EVs on distribution networks, evaluated in terms of investment and incremental losses, has been studied as well in [11]. Recently, new conceptual frameworks have been developed with respect to technical management and market operation for EV integration in electric power systems [3]. All these works mentioned above, and many others, have in common the necessity of making some assumptions related to the number of vehicles and charge stations considered, the charging rates, the modeling of the vehicle's battery and its storage capacity, as in [12], the strategy to carry out the coordination between the different agents or even a reference behavior that represents where and when EVs can charge/discharge.

Regarding those mentioned above, another agent is defined. This agent is called electric vehicle agent and is responsible for EV management, that is to say, it can decide when and where its vehicles will charge or discharge and how much energy it is willing to buy or sell in each period of time. This decision process is carried out according to particular restrictions related to vehicles and taking into account a known reference behavior of EVs.

The architecture developed for agents, according to the ideas explained, allows classifying into four types of agents, see Fig. 1:

- Participants: they are owners of particular elements of the microgrid: loads, generators, batteries or any combination of them.
- Electric vehicle agent: agent responsible for the management of EVs.
- Auctioneer: it has to distribute the energy from sellers to buyers considering specified rules of the auction.
- Technical agent: its main task is watch over the microgrid's feasible and optimal operation.

The process along the 24 hours of a day can be summarized in the following stages:

- 1) The participants and the electric vehicle agent carry out particular optimization problems in each period of time to decide how much energy are they willing to buy or sell. Each agent tries to maximize the difference between what they obtain from buying energy, incomes or utility, and the cost of this energy. In general, any agent may be seller or buyer.
- 2) The auctioneer takes the information from agents, energy been at stake and bids strategy and according to the rules of the auction determines the delivery of energy among the participants. Energy which is not cleared is obtained from the main grid.
- 3) The technical agent carries out an optimal power flow to get the MG to an optimal and feasible situation.
- 4) At the end of a period of time, every agent has its energy satisfied (from own generators, auction or main grid) and the electric vehicle agent has solved the management of its vehicles. Next period of time, the process goes back to step 1).

In this paper, compared to the work in [7], there have been introduced two new elements:

- The checking of the operation feasibility, done by the technical agent.
- The EVs management, developed by the electrical vehicle agent.

It is expected that this new system configuration facilitates the integration of renewable sources and EVs and also permits a safer operation of MGs.

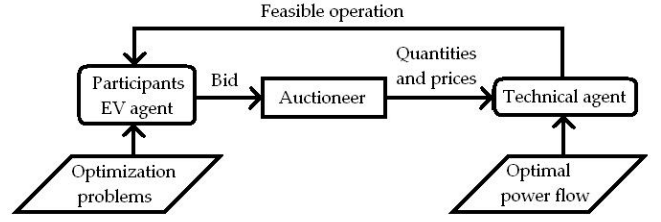

Fig. 1. Flow Diagram and agent architecture for the proposed operation

The global objectives to be achieved are the following:

- To get a more autonomous MG that can manage its own energy generation reducing the dependence on the main grid.
- To make the most of energy produced by renewable generators and counting with the support from other generators and batteries.
- To develop a feasible market-oriented operation where the different elements of the MG stand integrated.

IV. OPTIMAL POWER FLOW AND EV MANAGEMENT

In this section, the optimization problems referred to the EV management and OPF are described.

The objective function for an agent with EV is similar to those of the rest of agents belonging to the MG, [7]. It is formulated as the difference between the incomes from energy sold (or discharged) by the EVs and the cost from energy bought (or stored) in their batteries provided that the transaction is carried out with the main distribution grid:

$$\text{maximize } \sum_{t=t_0}^{t_f} (\lambda_t^b \cdot P_{t,j}^S - \lambda_t^s \cdot P_{t,j}^B) \quad (1)$$

Subject to the following restraints:

a) Logical conditions:

- The EV agent cannot sell and buy at the same time.
- An EV is not allowed to charge and discharge simultaneously.

b) Definition of equation to sell/buy: The EV agent sells or buys as a global result from charge/discharge of its vehicles. In that sense, the difference between the energy to sell and the energy to buy in a particular period of time t is expressed as the sum, extended to the total number of EVs and nodes of the microgrid, of the difference between the discharge energy and charge energy:

$$P_{t,j}^S - P_{t,j}^B = \sum_{n=1}^N \sum_{v=1}^V (P_{t,v,j}^{d,n} - P_{t,v,j}^{c,n}) \quad (2)$$

c) The charging and discharging rate have an upper and lower limit depending on the node, i.e. the station, and the type of EV, i.e. Plug-in Hybrid electric vehicle (PHEV) or Battery electric vehicle (BEV):

$$P_{v,n}^{min} \leq P_{t,v,j}^{d,n} \leq P_{v,n}^{max} \quad (3)$$

$$P_{v,n}^{min} \leq P_{t,v,j}^{c,n} \leq P_{v,n}^{max} \quad (4)$$

These variables are also restricted by the operational conditions in each period of time described later.

d) Regarding the energy level of the EV batteries, several restrictions have been considered.

- The energy level of an EV battery has an upper and lower limit related to its physical or chemical limitations:

$$S_{v,j}^{min} \leq S_{t,v,j}^b \leq S_{v,j}^{max} \quad (5)$$

- The energy level of an EV battery is scheduled at some periods of time. Therefore, there are periods of time where the energy level is fixed although there are others where the EV agent can freely decide what to do in order to maximize its objective function. It is important to notice that only those periods of time where the EV is connected to the microgrid are relevant and the value of energy level does not matter while the EV is running. Only the energy levels before the EV leaves the electrical node and when it comes to it are considered:

$$S_{t,v,j}^b = S_{t,v,j}^{sch} \quad (6)$$

- The energy level of an EV battery has to reach the maximum value at a particular period of time t_{full} during the early morning:

$$S_{t,v,j}^b = S_{v,j}^{max} \quad t = t_{full} \quad (7)$$

It is assumed that EVs return home to get the maximum level for their batteries.

- There is a relationship between the energy level in a period of time and the energy level in a previous period via an efficiency charge coefficient and power flow through the battery in those nodes in which the EV is connected:

$$S_{t,v,j}^b - S_{t-1,v,j}^b = \eta_{Cv} \cdot P_{t,v,j}^{c,n} - (1/\eta_{Dv}) \cdot P_{t,v,j}^{d,n} \quad (8)$$

The EV agent tries to make the most of its vehicles satisfying the operation constraints and selling energy if possible. The charge or discharge for the EVs is taken as a whole, that is, as it has been presented, that the agent sells or buys energy taking into account the combined effect of every EV into the microgrid. In other words, the agent behaves as a fleet manager.

As it was stated above, next the optimal power flow problem is described. The equations below are valid for a particular period of time t , the subscript is omitted for simplicity.

The objective function for the OPF problem is formulated as the sum of three terms, in absolute value, related to the active power supplied from the microgrid generators and the main distribution grid:

$$\text{minimize } k_1 \sum_{nrg} |\Delta P_{nrg}| + k_2 \sum_{rg} |\Delta P_{rg}| + k_3 |\Delta P_{grid}| \quad (9)$$

Where k_1 , k_2 and k_3 are positive parameters whose total sum is equal to 1 and subscripts nrg and rg make reference to the non-renewable generators and the renewable generators respectively. The relative weight among these values shows the tendency to vary one or another power.

Given the initial result from each agent optimization problem and the auction regarding active power generation, the technical agent tries to take the microgrid to a feasible situation minimizing the difference between the final power resulting from the OPF and the initial power resulting from the particular agent optimization problems. With respect to the terms in absolute value from the objective function, those can be expressed in the following way:

$$|\Delta P_{nrg}| = |P_{nrg}^f - P_{nrg}^i| \quad (10)$$

$$|\Delta P_{rg}| = |P_{rg}^f - P_{rg}^i| \quad (11)$$

$$|\Delta P_{grid}| = |P_{grid}^f - P_{grid}^i| \quad (12)$$

The absolute values were properly linearized although the resulting optimization problem is non-linear. The power supplied from non-renewable generators or main grid can be increased or decreased but it was considered that the power from renewable sources only can be reduced. For this latter case it is not necessary to use the absolute value although it was used to maintain the same linearization as the remainder of variables.

The constraints taken into account for this problem are the following:

a) Active and reactive power limits: the active and reactive power output for every generator cannot be higher (or lower) than a fixed quantity due to technical reasons:

$$P_{g,i,j}^{min} \leq P_{i,j}^G \leq P_{g,i,j}^{max} \quad (13)$$

$$Q_{g,i,j}^{min} \leq Q_{i,j}^G \leq Q_{g,i,j}^{max} \quad (14)$$

b) Voltage limits: the node voltages have to lie in a range of values between a maximum and a minimum:

$$V^{min} \leq V_n \leq V^{max} \quad (15)$$

c) Power flow constraints

- Power flow in lines is limited due to physical conditions related to the maximum heating that conductors can withstand:

$$(P_{nm})^2 + (Q_{nm})^2 \leq (S_{nm}^{max})^2 \quad (16)$$

- The active and reactive power flow equations for the microgrid lines are defined below:

$$P_{nm} = V_n V_m (G_{nm} \cos \theta_{nm} + B_{nm} \sin \theta_{nm}) - G_{nm} V_n^2 \quad (17)$$

$$Q_{nm} = V_n V_m (G_{nm} \sin \theta_{nm} - B_{nm} \cos \theta_{nm}) + B_{nm} V_n^2 \quad (18)$$

- The power flow modeled here is assumed to have no losses, that is to say, the active power flow leaving bus n to the bus m is equal to the power flow leaving bus m to the bus n :

$$P_{nm} + P_{mn} = 0 \quad (19)$$

d) Network equations

The AC network equations are considered here:

$$P_n = V_n \sum_{m=1}^M V_m (G_{nm} \cos \theta_{nm} + B_{nm} \sin \theta_{nm}) \quad (20)$$

$$Q_n = V_n \sum_{m=1}^M V_m (G_{nm} \sin \theta_{nm} - B_{nm} \cos \theta_{nm}) \quad (21)$$

Where P_n and Q_n are the active/reactive power injected to bus n , obtained as the difference between power injected by generating elements and that absorbed by loads.

V. CASE STUDY

The microgrid taken as reference is shown in Fig. 2.

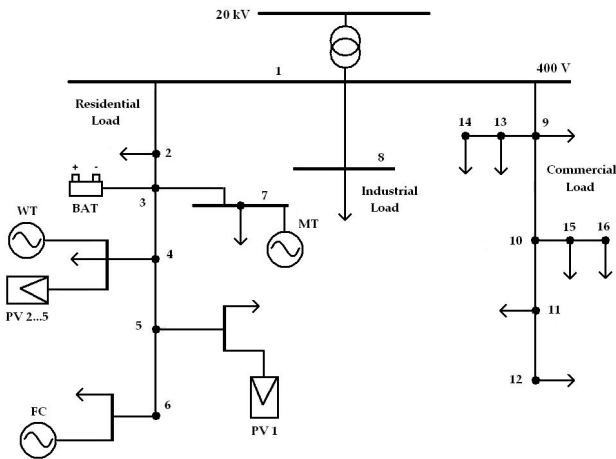

Fig. 2. Reference microgrid, [8]

The microgrid is composed of 16 nodes and three lines: residential, industrial and commercial. It is connected to the

main distribution grid from the point of common connection, node number 1. The industrial and commercial lines only have nodes that demand electric energy whereas the residential load contains a battery (BAT), photovoltaic cells (PVs), a wind turbine (WT), a fuel cell generator (FC) and a microturbine (MT).

The electric characteristics of the microgrid lines and the technical data of generators and the battery are listed in the Tables I-III:

TABLE I
ELECTRIC LINES CHARACTERISTICS OF THE MICROGRID

Line nodes		Resistance and reactance		Maximum line apparent power
From	To	R(pu)	X(pu)	Smax(kVA)
Grid	1	0.002500	0.010000	400.0
1	2	0.000100	0.000100	61.5
2	3	0.012425	0.003631	61.5
3	4	0.012425	0.003631	61.5
4	5	0.012425	0.003631	61.5
5	6	0.012425	0.003631	61.5
3	7	0.021744	0.003763	43.7
1	8	0.033000	0.008875	71.3
1	9	0.007444	0.005231	46.0
9	10	0.014888	0.010463	46.0
10	11	0.021525	0.011025	36.8
11	12	0.021525	0.011025	36.8
9	13	0.010763	0.005513	36.8
13	14	0.010763	0.005513	36.8
10	15	0.022838	0.005963	22.0
15	16	0.022838	0.005963	22.0

TABLE II
TECHNICAL GENERATION LIMITS

Generator	Active and reactive power operational restrictions			
	Pmin(kW)	Pmax(kW)	Qmin(kVAr)	Qmax(kVAr)
WT	0.0	10.0	-9.0	6.5
PV 2...5	0.0	2.5	-2.0	2.0
PV 6	0.0	3.0	-2.4	2.4
FC	6.0	50.0	-40.0	40.0
MT	3.0	30.0	-24.0	24.0

TABLE III
TECHNICAL BATTERY DATA

Battery	Maximum power flow and energy level			
	Pmin(kW)	Pmax(kW)	Smin(kWh)	Smax(kWh)
BAT	-10.0	10.0	0.0	30.0

These data are based on the work developed in [6], [8].

Additionally, the EV data referred to power flow limits, energy levels for batteries and efficiencies considered here are given in Tables IV-V.

TABLE IV
POWER FLOW LIMITS FOR EVS

Nodes	PHEV		BEV	
	Pmin(kW)	Pmax(kW)	Pmin(kW)	Pmax(kW)
n4, n5, n6	0.5	1.5	2.0	6.0
n8, n10	1.0	6.0	5.0	24.0
n14, n16	1.0	3.0	3.0	12.0

TABLE V
ENERGY LEVELS AND EFFICIENCIES FOR EVS BATTERIES

	S^{min} (kWh)	S^{max} (kWh)	η_c	η_D
EV1	2.0	6.0	0.90	0.95
EV2	2.0	6.0	0.90	0.98
EV3	6.0	24.0	0.95	0.98

The track followed for each EV is represented in Fig. 3.

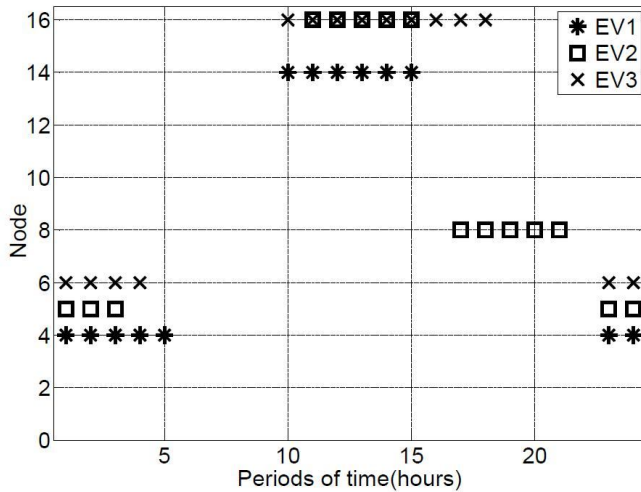

Fig. 3. Hourly location of EV1 in the microgrid

In section VI, the scheduled energy level for a reference EV is drawn together with the final values so the graph for this parameter is not given here.

VI. RESULTS

The method defined in section III was applied to the reference microgrid considering a typical energy demand and without forcing it to particular situations.

First at all, it should be kept in mind the main objectives pursued in this paper:

- Encourage the introduction of cleaner energies in the system. For this purpose the renewable energy is always included in the process and the OPF favours it against another kind of energy supplied either through the main grid or other non-renewable sources.
- Maximize the balance between the incomes from energy sold and costs from energy bought. This is something inherent to the optimization problems of the agents with generators.
- Redistribute the electric energy demand to make the most of the network and the available resources. A soft shift of the demand has been considered.
- Facilitate the operation of EVs in the microgrid, trying to avoid operational limits. Only three EVs have been considered with a reasonable track through the different charge stations along the microgrid.
- Get feasible situations in the microgrid trying to match the will of the different agents.

The results are presented in terms of:

- Energy supplied by generators.
- Profit of generators.
- Use of the microgrid battery.
- Technical management of the operation (OPF)

- EV management and its interaction.
- Shift of the flexible demand.

Fig. 4 shows the energy supplied for MT generator located in node number 7. The energy output is given in two ways. On the one hand, the continuous line represents the energy that the owner of the generator is willing to produce as a result from its optimization problem. On the other hand, the discontinuous line is the energy that the OPF determines for the MT to supply. However, the FC generator maintains its energy output at the highest level of 50 kWh during periods 19-22, the latter is not represented.

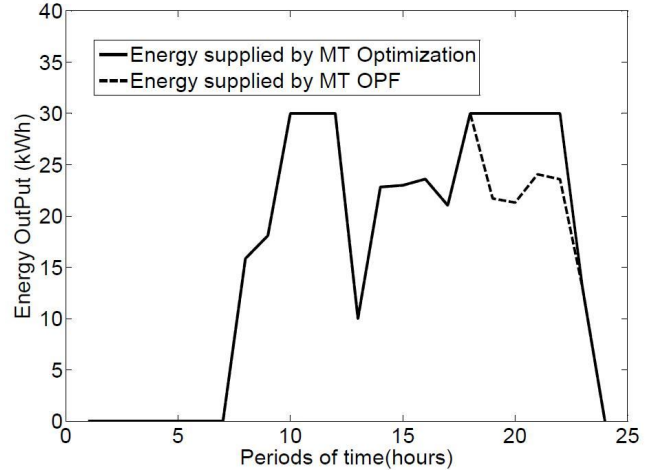

Fig. 4. Energy supplied by the MT

It can be seen that the difference is important around the period of time 20. That is because the OPF, in order to find a feasible operation, has to reduce the energy output from some generator. In fact, the OPF gives a value of 60.11 kW in line 1-2 that is a value near to the congestion of the line of the residential lines. Another fact is the voltage level in nodes 4, 5 and 6 which are all around 1.02 pu while in the remainder of nodes the node voltage is very close to the voltage base value. In that way, the technical agent takes the system to a possible situation.

It is important to underline that agents with non-renewable generators produce energy but satisfying its own demand at first and then selling the rest. Additionally, a good selling market price causes the generator not to supply any energy, that is, the agents prefers to buy energy from the main grid. If the OPF would have stepped down the energy supplied from the MT to the minimum in period 20 for example, the non-renewable agent had rejected to turn it on its generator because it would be losing the benefits of producing at a high level derived from the incomes of energy sold.

The microgrid battery charges when a better selling market price from the main grid is expected and discharges a little later near the peaks of price, see Fig. 5. It can be noticed that the battery even gets to full discharge in periods of time 1 and 12.

It should be taken into account that the search of a feasible operation is a result from all the elements inside the microgrid, in particular the battery that discharges strongly around the period 20, and active/reactive power requirements, not only

caused by the energy output from generators. The technical agent tries to find a situation which is near the agent's desire but satisfying the operational constraints.

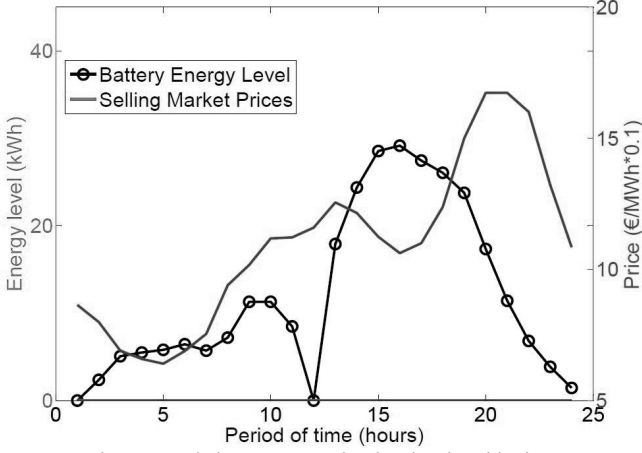

Fig. 5. Hourly battery energy level and main grid prices

Fig. 6 depicts different demand curves:

- Final demand: electrical energy required in all nodes of the microgrid in each period of time at the end of the process, taking into account the contribution of EVs.
- Fixed demand: electrical energy demanded that not varies in the process although is different from one period to another.
- Price responsive demand: electrical energy that can be shifted from one period to another. It has been established at 15% of the total demand of the microgrid.
- Initial configuration: electrical energy required in all nodes of the microgrid in each period of time at the beginning of the process, without taking into account the contribution of EVs.

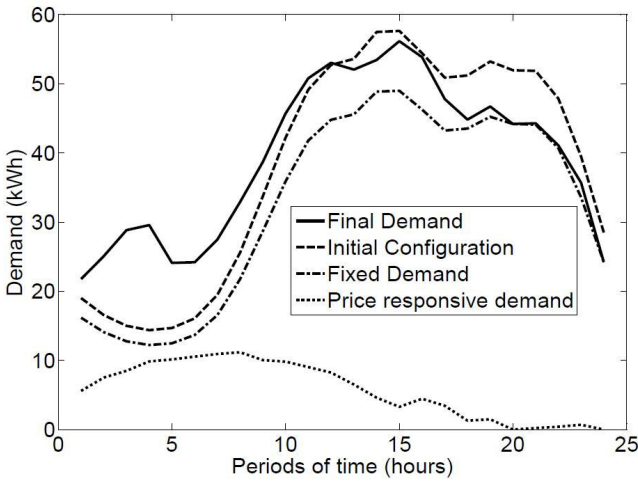

Fig. 6. Demand curves

The most relevant thing that has to be noticed here is that an important quantity of the price responsive demand is moved to those periods of time where a better selling market price is expected contributing in this way to a better exploitation of the microgrid. In fact, if we evaluate the shift coefficient (SC) defined as:

$$SC = \left(\sum_{t=1}^{24} (D_u^t - D_m) \right) / (24 * D_m) \quad (22)$$

where D_u^t is the total demand in period t and D_m is average demand, it gives a value of 0.283 for the final configuration and 0.391 for the initial configuration. Therefore, the final demand curve is flatter.

Anyway, these results have to be taken with care because EVs causes a non-negligible peak of demand in the early morning and around period of time 15 as it can be seen in Fig. 7 below. In this figure, the battery energy level for EV1 is represented against selling market prices. For the remainder of EVs this configuration is similar but depending on the particular scheduled energy level and track.

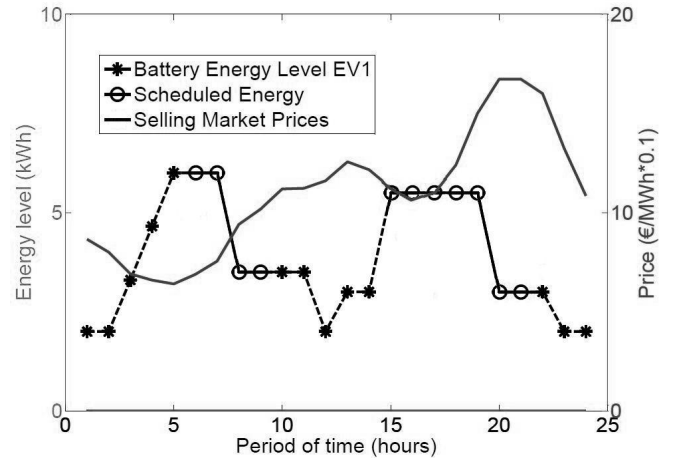

Fig. 7. Hourly EV1 battery energy level and main grid prices

In general, the behaviour of an EV battery is similar to a conventional storage battery with two main differences. Firstly, an EV battery can change the location in the microgrid and it is not necessary to stay connected all the time. Secondly, it has a scheduled energy level; in particular the EV battery has to reach full charge in the first periods of time. According to these ideas, it will charge in the early morning and in those periods of time where a better selling market price is expected. It will also discharge if it can get profit in this way. These effects can be appreciated in Fig. 7.

In Fig. 8, the total scaled demand curve, without contribution of EVs, together with generation from renewable resources and EVs energy supplied/demanded are drawn. The energy supplied from renewable generators turned out to be not modified by the technical agent and it is quite high around period of time 12 due to the combined effect of PV generators, whose supply is important during sun hours, and WT generator, which maintain an average level of supply the whole day. Along with EV energy discharged (negative in Fig. 8), the renewable energy constitute an important fraction of the total demand in the middle of the day. It has to be remarked again that EVs introduce a demand which should be taken into consideration.

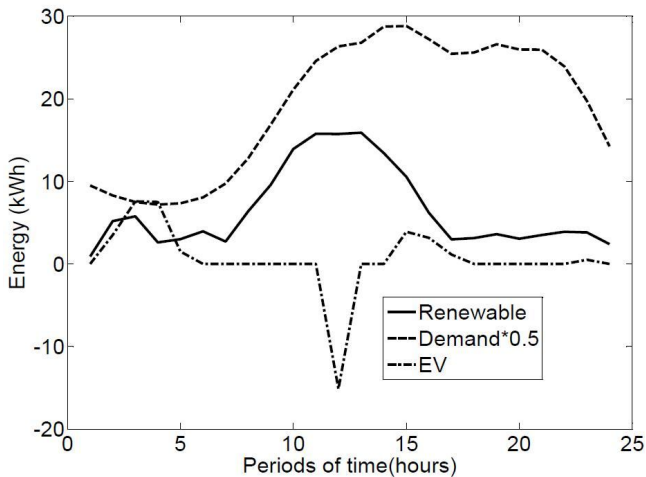

Fig. 8. Renewable energy output, total demand and EVs contribution

VII. CONCLUSION

In this paper, a decentralized approach for a technical and economic operation in a reference microgrid, involving different types of agents, has been presented.

It has been seen that, under this approach, renewable generators and EVs stand integrated. At the same time, non-renewable generators operate to satisfy its demand, get profit if possible and assist to the existing demand in the microgrid. In addition to this, a price responsive demand was considered and it proved that the demand in periods of time where the energy price from the main grid is less favourable, and there exists a higher quantity, can be reduced. The whole system is technically managed using an OPF to get a feasible situation trying to preserve the will of the different agents involved in the process.

According to this strategy, it should be taken into account that EVs integration is limited by the number of vehicles considered, the scheduled track (battery energy level as well) and the existing charging stations in the microgrid, for example. These factors may cause undesired peaks of demand.

VIII. REFERENCES

- [1] F. Katiraei, R. Irvani, N. Hatzigiorgiou, and A. Dimeas, "Microgrids management," *IEEE power & energy magazine*, pp. 54- 65, May/June. 2008.
- [2] R. Bhuvanawari, S. K. Srivastava, C. S. Edrington, D. A. Cartes and S. Subramanian, "Intelligent based auction by economic generation scheduling for microgrid operation," in *2010 Innovative Smart Grid Technologies (ISGT)*, pp 1-5. Gaithersburg, Maryland, USA.
- [3] J. A. Peças Lopes et al., "Integration of Electric Vehicles in the Electric Power System," in *Proceedings of the IEEE*, vol. 99, no.1, pp. 168-183, Jan. 2011.
- [4] J. M. Foster and M. C. Caramanis "Energy Reserves and Clearing in Stochastic Power Markets: The Case of Plug-In-Hybrid Electric Vehicle Battery Charging," in *2010 IEEE Conference on Decision and Control*, pp. 1037-1044, Atlanta, Georgia, USA.
- [5] A. Dimeas and N. Hatzigiorgiou, "Operation of a multiagent system for microgrid control" *IEEE Transactions on Power Systems*, vol. 20, no 3, pp. 1447-1455, Aug. 2005.
- [6] A. G. Tsikalakis and N. Hatzigiorgiou, "Centralized control for optimizing microgrids operation," *IEEE Transactions on Energy Conversion*, vol. 23, no 1, pp. 241-248, Mar. 2008.
- [7] M. A. López, S. Martín, J. A. Aguado and S. de la Torre "Market-Oriented Operation in Microgrids using Multi-Agent Systems," accepted

for the *2011 International Conference on Power Engineering, Energy and Electrical Drives*, Torremolinos, Spain.

- [8] S. Papathanassiou, N. Hatzigiorgiou, K. Strunz, "A benchmark low voltage microgrid network," in *2005 Proc of the CIGRE Symposium: Power Systems with Dispersed Generation*, Athens, Greece.
- [9] K. Clement, E. Haesen and J. Driesen "Coordinated Charging of Multiple Plug-in Hybrid Electric Vehicles in Residential Distribution Grids," in *2009 Power Systems Conference and Exposition (PSCE)* pp. 1-7, Seattle, Washington, USA.
- [10] G. B. Shrestha and S. G. Ang "A Study of Electric Vehicle Battery Charging Demand in the Context of Singapore," in *2007 Power Engineering Conference (IPEC)*, pp. 64-69, Singapore.
- [11] L. Pieltain, T. Gómez et al., "Assesment of the Impact of Plug-in Electric Vehicles on Distribution Networks," *IEEE Transactions on Power Systems*, vol. 26, no 1, pp. 206-213, Feb. 2011.
- [12] R. García-Valle and J. G. Vlachogiannis "Electric Vehicle Demand Model for Load Flow Studies," *Electric Power Components and Systems*, vol. 37, pp 577-582, 2009, Taylor & Francis.

IX. BIOGRAPHIES



M.A. López (S'11) was born in Málaga, Spain, in 1980. He obtained the Industrial Engineering degree from the University of Málaga in 2006.

In 2009, he joined the Electrical Engineering Department as a Ph. D. student. His main topics of interest include distributed generation, smart grids and multi-agent systems.



S. Martín (S' 08) was born in Malaga, Spain, in 1980. He graduated from University of Granada, Spain, as Civil Engineer in 2003, and from University of Málaga, Spain, as Industrial Engineer in 2007. He is currently pursuing the Ph. D. degree at the University of Malaga, Spain.

He is currently a Lecturer at the University of Málaga. His research interests include optimization theory, operations and economics of electric energy systems, stochastic programming, numerical analysis, computational methods, and teaching methodologies.

José A. Aguado (M'01) received the Ingeniero Eléctrico and Ph.D. degrees from the University of Málaga, Málaga, Spain, in 1997 and 2001, respectively.

Currently, he is an Associate Professor and Head of the Department of Electrical Engineering at the University of Málaga. His research interests include operation, planning, and deregulation of electric energy systems and numerical optimization techniques.



Sebastián de la Torre (M'04) was born in Málaga, Spain. He received the Ingeniero Industrial degree from the Universidad de Málaga, Málaga, Spain, in 1999; he obtained his Ph.D. degree on power systems operations planning at the Universidad de Castilla – La Mancha in 2003.

His research interests include operations and economics of electrical energy systems, restructuring of electric systems and development of new electricity markets. He is currently Assistant Professor in the Department of Electrical

Engineering at the Universidad de Málaga.