

# Investigation of Underwater Acoustic Modems: Architecture, Test Environment & Performance

Presented by:



Dr. Javier Poncela  
Department of Communications Engineering  
University of Malaga, Spain

# Index

- Introduction
- Investigation of Underwater (UW) acoustic modems
  - Architecture
  - Specifications
  - Testing environment
  - Results
- Comparative Analysis
- Conclusion

# Introduction

- Underwater (UW) acoustic communication have several design challenges which need to be carefully address including modem size, power consumption, interference, data-rate and communication distance.
- In this presentation, recent developments in UW acoustic modems in last five years are investigated.
- From last five years (2 samples per year) are presented here.
- The architecture, specifications, testing environments (indoor/outdoor) and results are discussed.
- Qualitative analysis of UW acoustic modems is also presented.
- This investigation is useful for researchers and designers of the domain.

# SeaModem

- Developed by the University of Calabria, Italy, (2015). (<http://www.applicon.it/>)
- Open hardware/software platform for UW communication.
- Consists of Power and DSP boards as shown in fig. 1.
- Class D amplifier can transmit up to 40W in different levels.
- Operates in the 25-35 kHz frequency band.
- Piezo-ceramic transducer is used for communication.
- Power board has switch to use single transducer as transmitter/ receiver.
- It uses MFSK modulation with selectable (2-4-8) tones with data-rate 750, 1500, 2250 bps.
- DSP board consists of TMS320C5000™, 16 bits audio CODEC and NOR flash memory.
- To provide user interface UART serial port is used.

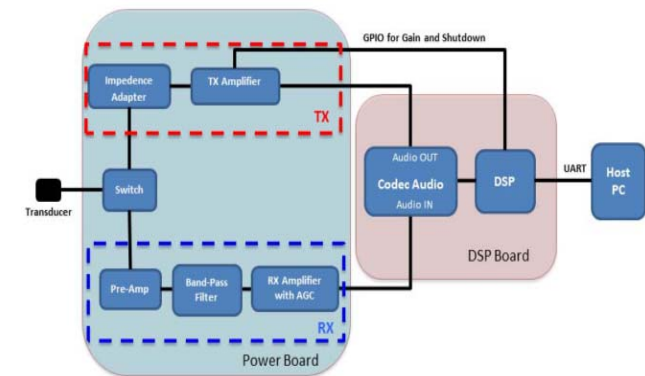

Fig. 1. SeaModem block diagram

## SeaModem (*cont...*)

- Error detection and correction is performed by cyclic redundancy check and Viterbi algorithms respectively.
- The modem uses TCP-like (two-way with ACK) and UDP-like (one-way without ACK) communication protocols.
- SeaModem network architecture allows one to address up to 15 modems within the same area.
- The modem allows one to calculate range by two different (one-way) and (two-way) range estimation methods.
- It allows to add a guard period between symbols to reduce inter-symbol interference.
- It also provide capability to host BeagleBone for additional functionalities as shown in fig. 2.
- Sound speed estimation and time-stamp are also possible on each TCP and UDP packets.



Fig. 2. SeaModem Power & DSP boards.

# SeaModem (cont...)

- The modem was tested in 100m long, 3m deep pier (noisy due to the presence of boats) as shown in fig.3.
- The modem transducers were kept at about 1m depth.
- The modem was tested by taking the average of five range measurements for each of 20 range points.
- The absolute and relative ranging errors are shown in fig. 4 and 5 that is always kept under one meter.



Fig. 3. Test environment

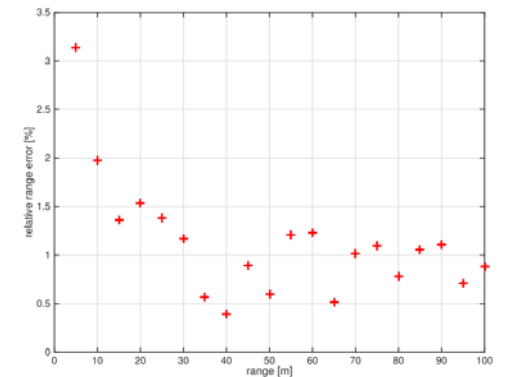

Fig. 4. Relative ranging error

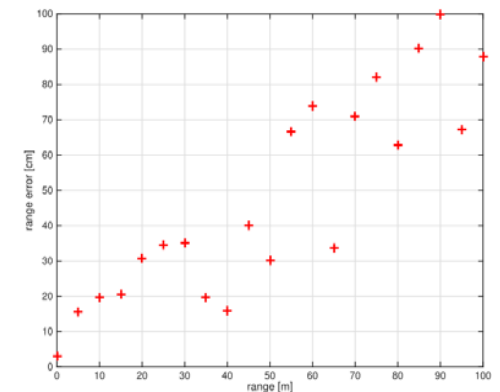

Fig. 5. Absolute ranging error

# Seatrac

- Developed by Newcastle University, UK (2015) as part of EU FP7 project CADDY (<http://www.caddy-fp7.eu/>).
- The objective of CADDY project was to make a network of diver, small AUV and small ASV to improve safety.
- The modem is based on 150MHz ARM Cortex M4 processor.
- It operates in the frequency band of 24-32 kHz.
- The combined modem/USBL unit is shown in fig. 6.
- The size of modem is 55mm x 160mm.
- Class D amplifier is used to transmit signals.
- It includes various sensors including:
  - pressure sensor
  - temperature sensor
  - 3-axix gyro
  - accelerometer
  - compass

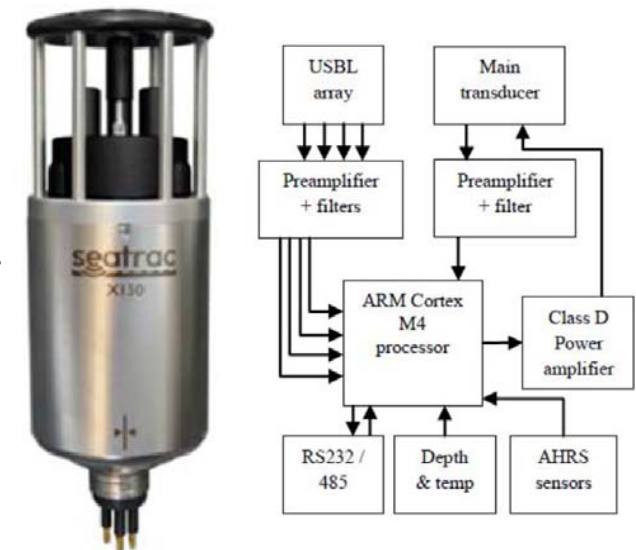

Fig. 6. Seatrak modem

# Seatrac (cont...)

- The modem has been tested using SS with low data rate 100bps in the range of 1.5 km.
- Short messages were exchanged between a pair of devices, the packet delivery rates were between 95-100%.
- The estimated positions in X-Y plane is shown in fig. 7.
- Fig. 8 shows (a) X-Z plane positions & (b) standard deviation (SD) of position vs range.

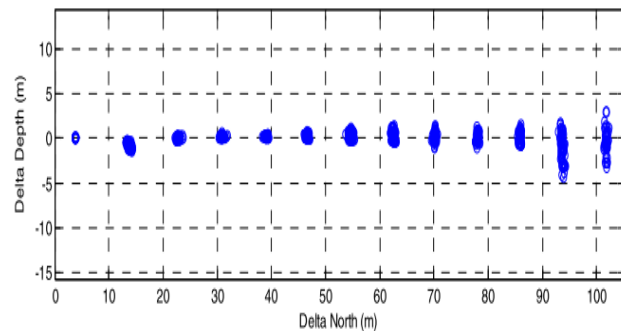
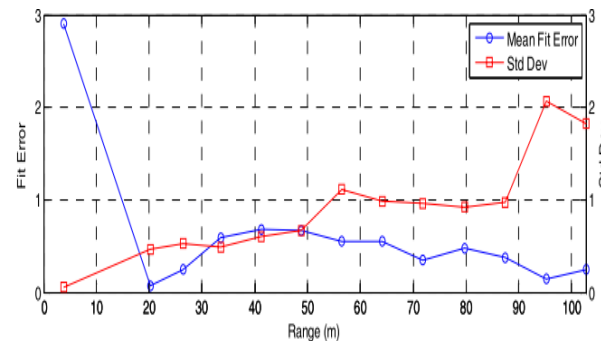

Fig. 8. (a) USBL positioning dock trial Y-Z plane)



(b) SD of positioning and mean fit error vs range

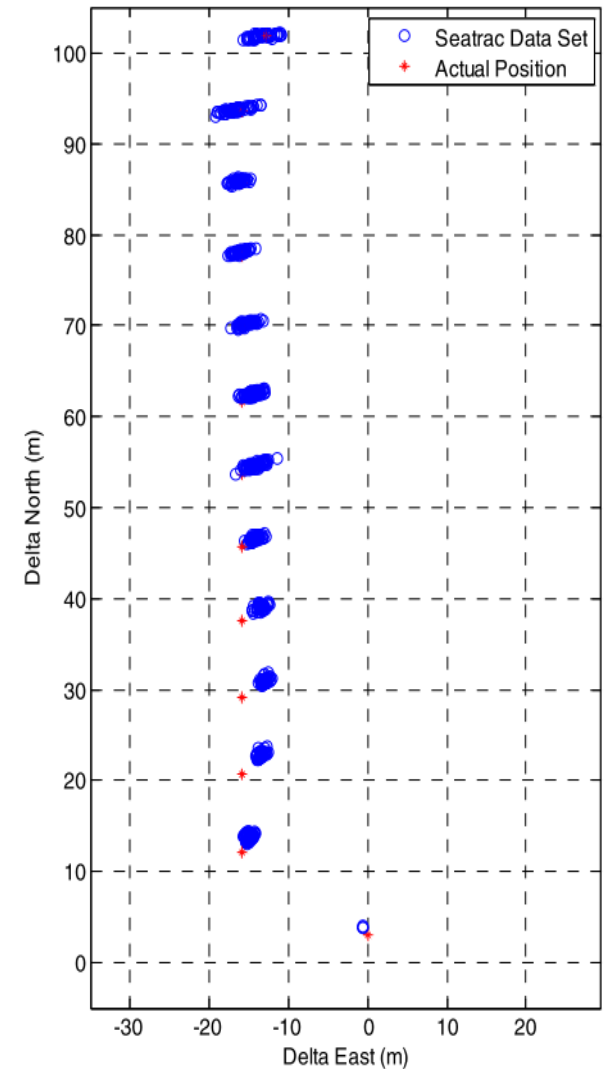

Fig. 7. USBL positioning dock trial (X-Y plane)



# Seatrac (cont...)

- Medium data-rate (1.4kbps) SS transmission was carried out in shallow water channels.
- Signals were recorded and processed offline using system parameters shown in fig. 9.
- Fig 10-11 shows the results from the transmission of 200 packets over a distance of 1.6 km in 10m deep channel.
- Fig. 10 shows the output signal to interference (SIR) + noise ratio (SINR) is plotted over the 200 packets.
- Fig. 11 shows the number of errors measured in each packet which deteriorates with the ship noise .

Parameter	Symbol	Value
Chip rate	$f_{chip}$	8000
Spreading ratio (chips/symbol)	$L$	8
RS code rate	$(N,K)$	(255,191)
Training sequence length	-	255 chips
Net data throughput	-	1.39 kbits/s
Transmit source level	-	174 dB re 1 $\mu$ Pa
LFM chirp	-	B=8 kHz, T = 50ms
Adaptive filter length	-	36 taps
Adaptive step size	$\mu$	0.02 training, 0.005 for data
Doppler tracking constant	$k_p$	$2 \times 10^{-5}$ training, $5 \times 10^{-6}$ for data

Fig. 9. DSSS system parameters

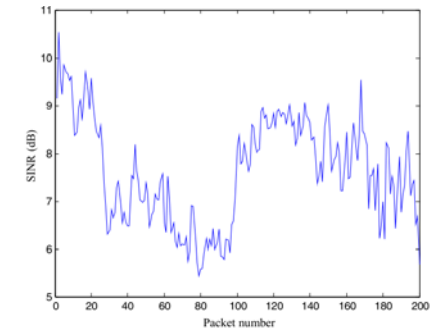

Fig. 10. Output SIR + noise ratio

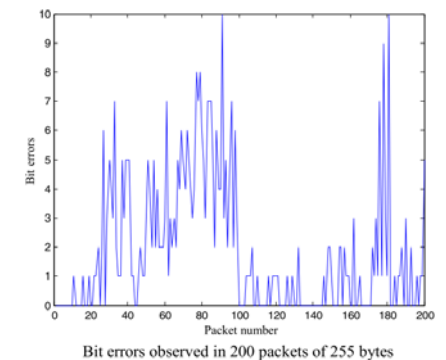

Fig. 11. Bit errors in 200 packets

# Micro-Modem

- Developed by Gangneung-Wonju National University, Korea, (2014).
- The size of modem is small 70mm x 40mm, consumes low-power and works at moderate distance and data-rate.
- The prototype and block diagram is shown in fig. 12-13.
- Following are the specifications.
  - MCU - STM32F103 (Cortex M3).
  - Resonant frequency 70kHz.
  - Power consumption is 8W.
  - Transducer size 34mm.
  - Battery 29.6V, 8.8AH (Li-ion)
  - Power consumption 8W



Fig. 12. Prototype of micro-modem

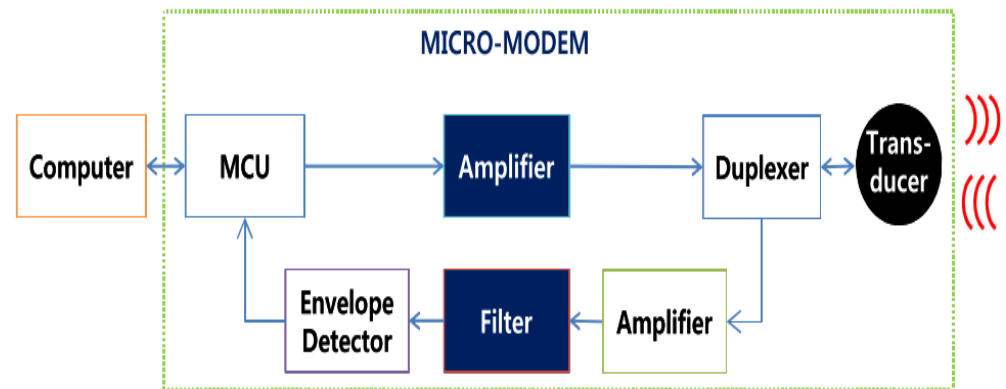

Fig. 13. Block diagram of micro-modem

# Micro-Modem (*cont...*)

- The first test was performed in a pond 80m x 40m and 6m deep as shown in fig. 14.
- Two modems were deployed in the LOS path and transducers were submerged in 1m deep.
- Error performance of the modem was investigated at the distance of (D) 30m & 60m with different data rates.
- 200 frames were transmitted for each tests.
- The error rate increases gradually as the data-rate increase as shown in fig. 15.
- Due to shortened symbol duration, communication was not possible after 500 bps.

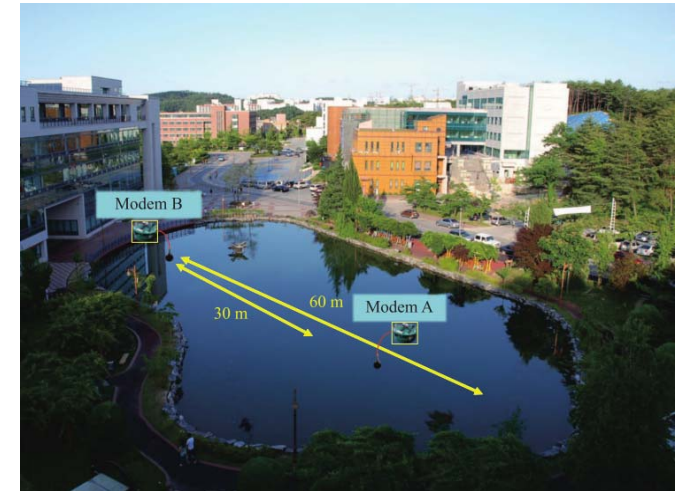

Fig. 14. Experimental setup for pond tests.

Data rate	D=30 m		D=60 m	
	FER	BER	FER	BER
200 bps	$1.0 \cdot 10^{-2}$	$7.8 \cdot 10^{-5}$	0	0
300 bps	$1.3 \cdot 10^{-1}$	$1.3 \cdot 10^{-3}$	$4.5 \cdot 10^{-2}$	$4.3 \cdot 10^{-4}$
400 bps	$8.0 \cdot 10^{-1}$	$5.7 \cdot 10^{-2}$	$8.0 \cdot 10^{-2}$	$2.4 \cdot 10^{-3}$
500 bps	$8.0 \cdot 10^{-1}$	$6.9 \cdot 10^{-2}$	$7.0 \cdot 10^{-1}$	$1.3 \cdot 10^{-2}$

Fig. 15. Error rates w.r.t. distance and data-rate.

## Micro-Modem (*cont...*)

- The second test was performed in Gyeongpo lake in Korea (1.6 x 0.7) km and 3m deep with salinity.
- FER and BER measured at distances 100 to 500 m with fixed data-rate 5kbps are shown in fig. 17.
- Two hundred frames with 16-byte data were transmitted to obtain results.
- Results show that the error free communication was possible at 100m and performance was degraded gradually as distance increases up to 500m.
- The error-rates could be lowered by reducing data-rate or applying channel compensation.



Fig. 16. Experimental setup for lake tests.

D	FER	BER
100 m	$5.0 \cdot 10^{-3}$	$3.9 \cdot 10^{-5}$
200 m	$6.0 \cdot 10^{-2}$	$1.1 \cdot 10^{-3}$
300 m	$8.5 \cdot 10^{-2}$	$3.2 \cdot 10^{-3}$
500 m	$2.8 \cdot 10^{-1}$	$4.0 \cdot 10^{-2}$

Fig. 17. Error rates w.r.t. distance.

# UW Acoustic Modem

- Developed by Northwestern Polytechnical University, China, (2014).
- The block diagram and basic framework of UWA modem is shown in fig. 18-19.
- It is based on dual-core OMAP-L138 floating and fixed-point DSP processor.
- The work mode of the communications platform is classified as transmitting, receiving and sleeping mode.
- The parameters including work status, system status, port selection and baud rate are set via PC and assigned to the DSP through serial port.

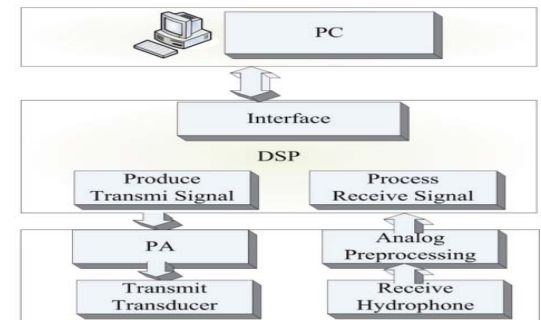

Fig. 18. Hardware architecture

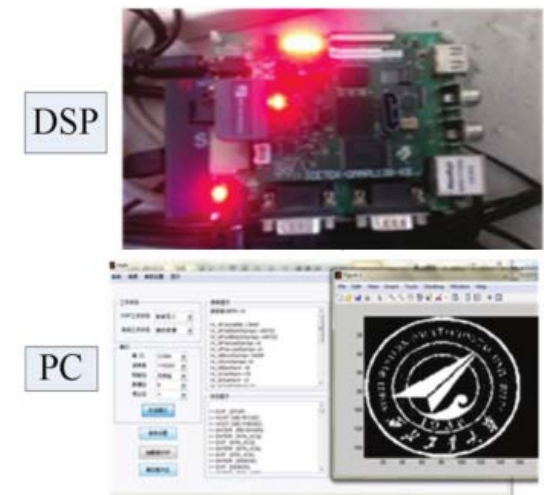

Fig. 19. Communication platform framework

# UW Acoustic Modem (cont...)

- The modem has been tested in lake experiments at the distance of 10 km as shown in the fig. 20.
- After launching the hydrophones the boat engines were turned off to keep a quite environment.
- The communication rate reached up to 4kpbs with BER performance  $10^{-3}$  to  $10^{-4}$ .
- Channel estimation results are shown in fig. 21, which has obvious sparse features, containing 3 main path and the max. delay spread reaches 35ms.
- The error rate statistics presented in fig 22, shows that major portion of the error blocks occurred at frame 3 and 8 when other ship was passing by the receiver.

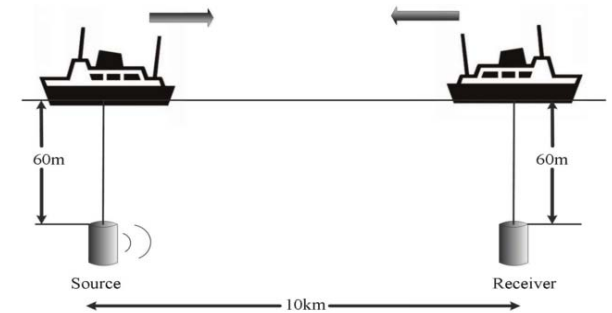

Fig. 20. Configuration of the lake experiment.

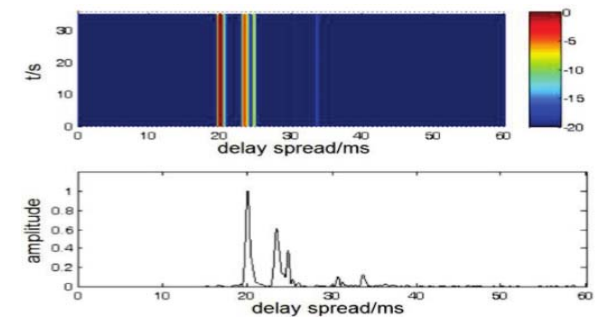

Fig. 21. Estimated channel response.

Frame	BER
1	0.006666
2	0.004166
3	0.011667 ←
4	0.007500
5	0.000000
6	0.001667
7	0.005000
8	0.010000 ←
9	0.003333

Fig. 22. The error rate statistics.



# Full duplex multi-user modem

- Developed by Harbin Engineering University, China, (2013).
- Block diagram of the modem is shown in the fig. 23.
- The modem consists of two digital boards, a pre-amp board, a power amplifier board and MSP430 main controller board as shown in fig. 24.
- It uses OFDM and CDMA with SS for realizing full-duplex and multi-user communication.
- A TMS320C6455 DSP board process digital signals in real time for OFDM and S3C2440 ARM board is used for SS processing.

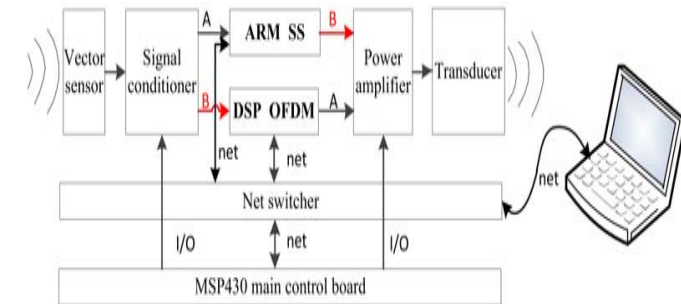

Fig. 23. Block diagram of modem

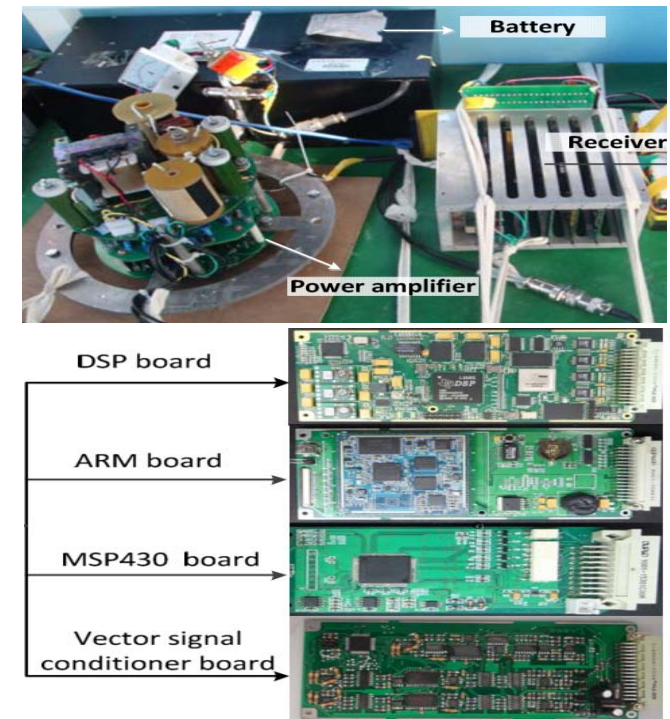

Fig. 24. Modules of modem

# Full duplex multi-user modem (cont...)

- The experiments were conducted in Yellow sea in China.
- Modem 1 and 2 were operating under full-duplex mode, while modem 3 was operating in multi-user mode as shown in fig. 25.
- The average depth was 20m and the modem depth was 5m.
- The full-duplex function was verified by two modems at a distance of 3km with data-rate OFDM (710bps) and SS (10bps).
- Multi-user operation was verified by three modems with data-rate OFDM (710bps) and SS (19bps).
- Fig. 26 shows sound speed profile (with blue line) and sea water temperature (with red line).
- Channel impulse response (CIR) is shown in fig. 27.

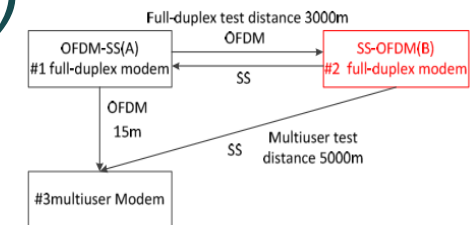
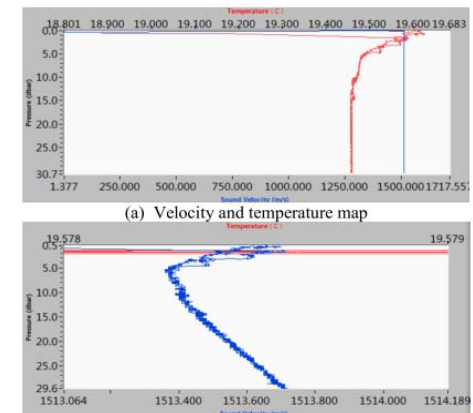

Fig. 25. Modem testing scenario.



(b) sound speed profile after partially enlarged  
Fig. 26. Sound speed profile.

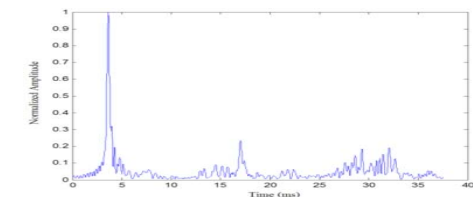

Fig. 27. Channel impulse response.



# UW bio-mimetic fish robots

- Developed by Gangneung-Wonju National University, Korea, (2013).
- The research was focused on real-time water quality monitoring system using bio-mimetic fish robots.
- The working range of each fish robot is set to 500m from the docking station.
- The max. data-rate for acoustic communication was determined to 4.8kbps.
- The circular shape modem 70 mm x 40 mm consists of two analog transmission and reception boards and one digital board as shown in fig. 29.
- Fig. 30 shows a commercial USBL system adopted for this application.

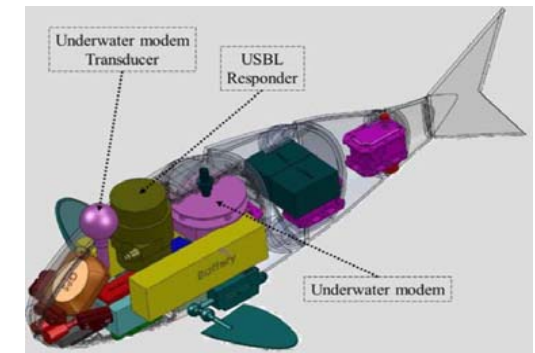

Fig. 28. Fish robot.

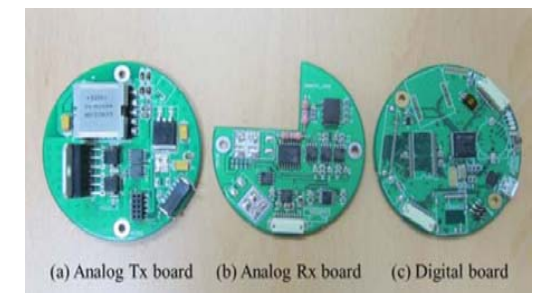

Fig. 29. Acoustic modem.



Fig. 30. USBL System.

# UW bio-mimetic fish robot (*cont...*)

- The experiments were conducted in Gyeongpo lake, Korea and results are summarized in fig. 31.
- For each experiment to acquire a BER, 400 frames consisting of 16 bytes were transmitted at data-rate of 5kbps.
- The error at a distance of 350 m could be due to underwater creature and topography.
- The system-level experiment was conducted in Han river (930m wide and 10 m deep) near Seol as shown in fig. 32.
- An UW communication link was formed between the docking station and the bio-mimetic fish robot to control and report UW sensing data in real-time.

Distance	Number of errors	BER
50 m	0	0
100 m	0	0
150 m	0	0
200 m	0	0
250 m	0	0
300 m	0	0
350 m	108	$2.109 \times 10^{-3}$
400 m	0	0
450 m	0	0
500 m	3	$5.859 \times 10^{-5}$

Fig. 31. BER performance of modem

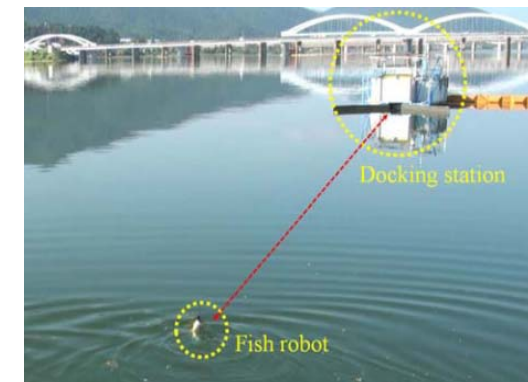

Fig. 32. System level test in Han lake.

# Bidirectional Acoustic Modem

- Developed by Gangneung-Wonju National University, Korea, (2012).
- The size of modem is 70mm x 35mm with cylindrical shape.
- It consists of analog transmission and reception boards and digital MCU board as shown in the fig. 34.
- Binary modulation scheme with non-coherent detection is used in the modem.
- To provide omni-directivity, a commercial transducer is used with the modem.
- The modem can communicate bi-directional using the same transducer.

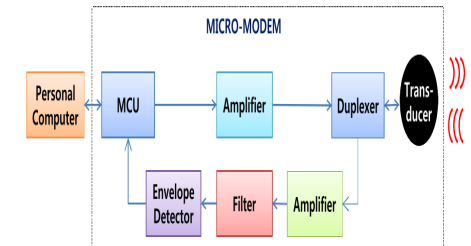

Fig. 33. Block diagram.

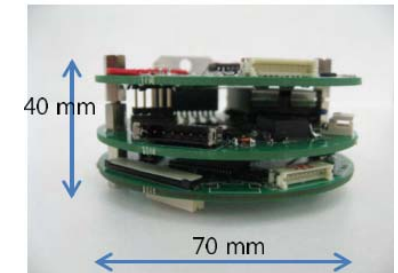

Fig. 34. Modem prototype.



Fig. 35. Transducer.

# Bidirectional Acoustic Modem (cont...)

- For in-door lab tests, small water tank of size (2.9x 0.75x 0.6) m was used and transducers were in LOS at center of water tank.
- Field tests were performed in 500m wide & 15 meter deep river.
- The results shows BER around  $10^{-3}$  can be achieved up to 100 meters. As distance increased by 150 meters, the BER deteriorates as shown in fig 38.
- It was observed that up to the distance of 500 m reliable communication was possible when 26 kHz resonant frequency transducer was used.

	$p = 10^{-1}$		$p = 10^{-2}$	
	analysis	experiment	analysis	experiment
$T = 31$	0.9618	0.9240	0.2677	0.3420
$T = 29$	0.8304	0.5420	0.0383	0.0160
$T = 27$	0.6114	0.1700	0.0036	0.0040
$T = 25$	0.3761	0.0369	0.0003	0.0000

Fig. 37. Packet loss probability in water tank experiment.

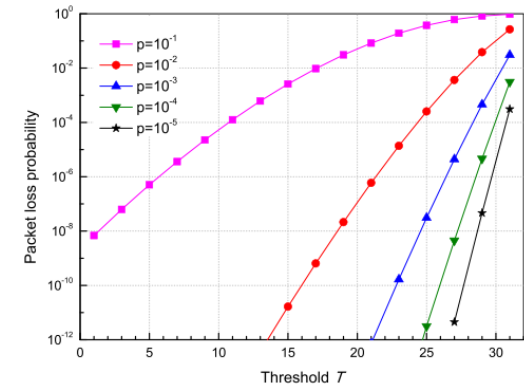

Fig. 36. Packet loss probability w.r.t.  $T$ ;  $L=31$ .

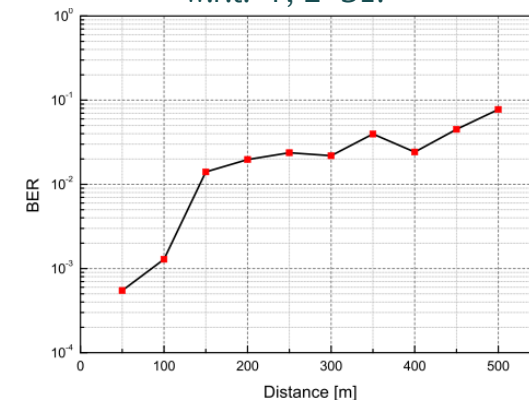

Fig. 38. BER w.r.t. distance.

# High Reliable chirp UW Modem

- Developed by Key Lab. of UW Acoustic Comm. & Marine Information Technology, China.
- Hardware design is based on software defined radio (SDR) as shown in fig. 39. To exchange data in real-time, between PC and modem UART is used.
- The size of modem is 10 cm x 7.5 cm x 5 cm which includes two digital and analog boards and a transducer as shown in the fig. 40.
- It is based on M-ary different chirp spread signals (MCSS) with onboard TMS320DM642.
- At the transmitter, one information symbol carries  $k$  bits messages. The receiver consists of a bank of correlators, and each correlator matches to one of the four possibilities if transmitted orthogonal sequences.

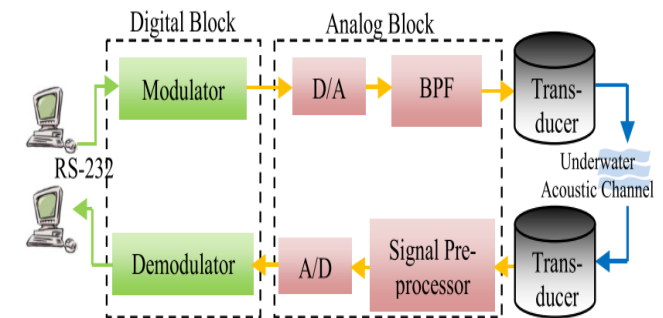

Fig. 39. Block diagram.

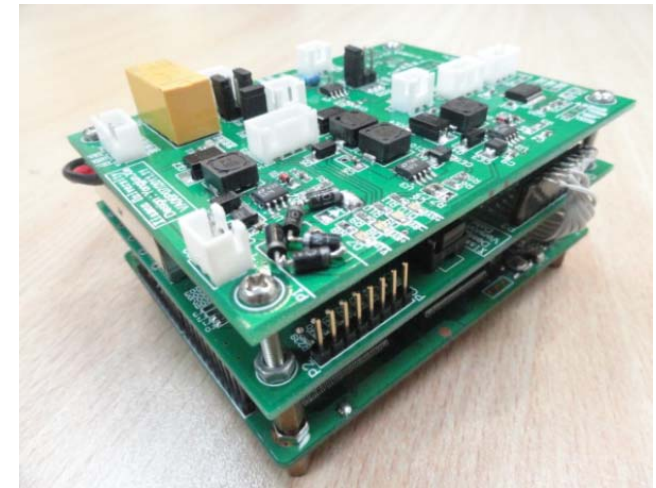

Fig. 40. Modem prototype.



# High Reliable chirp UW Modem (*cont...*)

- Pool and sea tests were performed to validate results of the modem.
- The transmitting frequency range was in between 20 kHz – 30 kHz with (200 to 300) bps data rates. The experiments were repeated at a distance of 20 m for error-free transmission with 100 kHz sampling frequency in 25 m x 6m pool.
- Sea tests were carried out in Wuyuan Bay, China. The data rate was 300 bps with zero bit error rate at a distance of 212 m and transmission power was less than 0.97W.
- Fig 41-42 shows the noise and signal received from the modem.

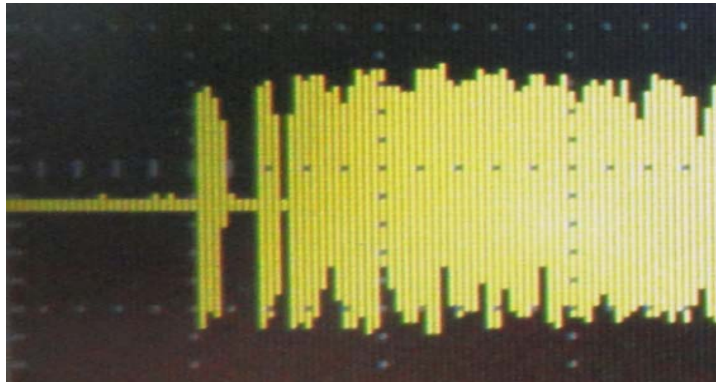

Fig. 41. Transmitter.

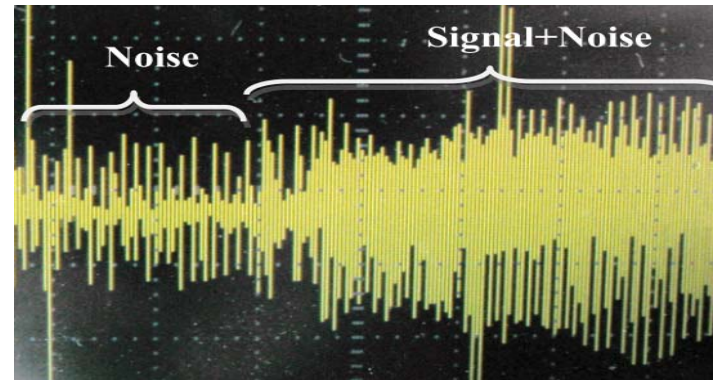

Fig. 42. Receiver.

# A Low-cost and High-efficient Modem

- Developed by Universitat Politecnica de Valencia, Spain, (2011).
- The modem consists of 8-bit microcontroller with additional components and the circuit as shown in the fig. 43.
- Due to the efficiency in term of bandwidth, binary coherent frequency shift keying modulation scheme is used.
- Commercial piezoelectric transducer, Hummingbird XP 9 20, is used in the modem with 85kHz frequency to reduce the cost of the system.
- During the experiments, 1kpbs data-rate with 1kHz BW. was achieved.
- The modem prototype is shown in fig. 44.

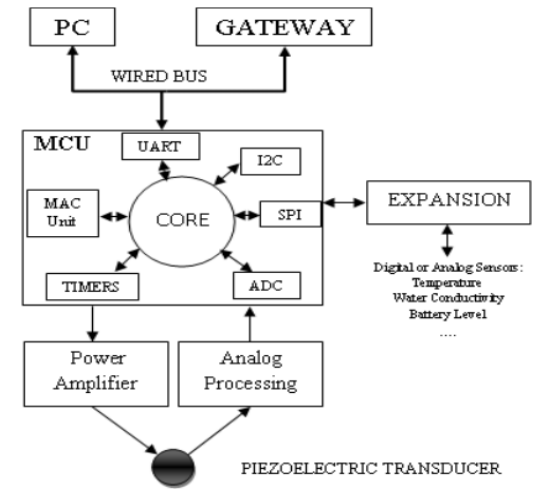

Fig. 43. Block diagram.

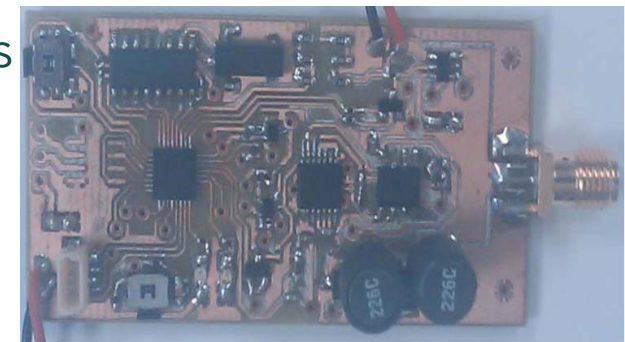

Fig. 44. Modem prototype.

# A Low-cost and High-efficient Modem (*cont...*)

- The modem was tested in the port of Gandia, Valencia (Spain).
- In horizontal test successful communication was possible up to 100 m distance between the modems inside the port area as shown in fig 45(a)
- The vertical testing was performed inside and outside of the port with the distances of 10 m and 17m respectively with successful reception as shown in the fig. 45(b) and (c) .
- Received signal levels could not be measured accurately due to unavailability of environmentally protected instruments.
- The experimental results of in-door test performed in 20m x 8 m water tank are shown in fig. 46.



Fig. 45. Horizontal and vertical testing environment.

Power amplifier Voltage	5V	10 V
Power dissipated by AB-class custom amplifier	43 mW	191 mW
Power dissipated by D-PP-B-class amplifier	16 mW	68 mW
Power transferred to the transducer	12 mW (10dBm)	48 mW (17dBm)
Received input voltage	34 $\mu$ V	66 $\mu$ V

Fig. 46. 20m horizontal communication results.



# Omni-directional UW Acoustic Modem

- Developed by Gangneung-Wonju National University, Korea, (2011).
- The modem consists of transducer, analog and digital blocks as shown in the fig. 48.
- The ARM Cortex-M3 processor is used in the modem with 14.8 lithium battery.
- The modem is controlled by a PC using RS-232 interface.
- The analog board is equipped with a transformer, which can supply voltage up to  $200V_{pp}$  to the transducer.
- The transducer used in the design has resonant frequency of 70 kHz and can supply up to power of 190W.

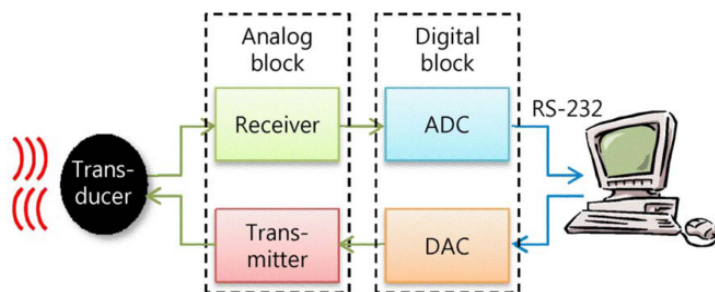

Fig. 47. Block diagram.



Fig. 48. Modem prototype

# Omni-directional UW Acoustic Modem (cont...)

- Indoor performance evaluation of the modem was conducted in a water tank as shown in the fig. 49.
- The transducers were placed in the water medium at a distance of 200 cm and modems in front of the water tank.
- The modems were connected to the laptops using RS-232 cable to control and monitor data transmission.
- The error-free transmission was possible at a data-rate of 0.2kbps at a distance of 200 cm in water tank, as shown in fig. 50.
- An outdoor experiment was conducted in a 40m x 60m x 1m pond at a distance of 40 m, with data rate of 0.2 kbps and BER  $3.3 \times 10^{-4}$ .

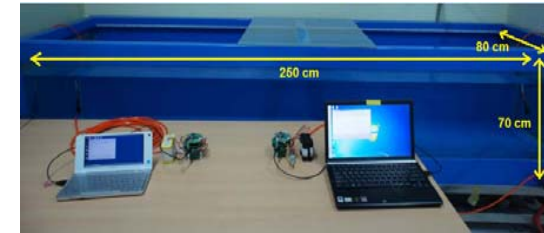

Fig. 49. Indoor experimental environment.

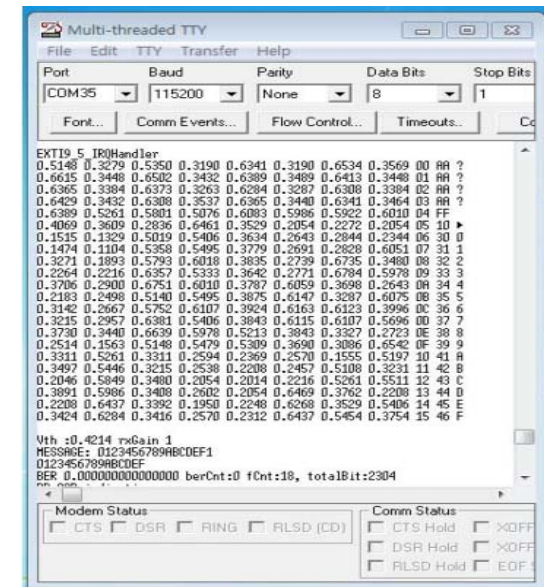

Fig. 50. Experimental results.

# UW acoustic modems designed in last 5 years

Modems	Year	Platform	Range (m)	Data Rate (bps)
SeaModem	2015	TMS320C5000	100	750, 1500, 2250
Seatrac	2015	Cortex-M4	1500	100
Short range micro-modem	2014	Cortex-M3	60	500
UW Acoustic modem	2014	OMAP-L138	10,000	4000
Full-duplex multiuser modem	2013	TMS320C6455 and Cortex-A8	3000	OFDM 710 SS 19
UW bio-mimetic fish robots	2013	-	500	5000
Bidirectional acoustic micro-modem	2012	-	500	1000
High reliable chirp UW acoustic modem	2012	TMS320DM642	212	300
Low cost - high efficient modem	2011	8-bit Microcontroller	100	1000
Omni-directional UW acoustic modem	2011	Cortex-M3	40	200

# Conclusion

- Ten modems have been investigated from the last five years (two samples per year).
- It is found that TMS320 DSP and Cortex are leading platforms used in modem development.
- Each modem has a different architecture and designed for different applications, hence it is difficult to draw qualitative conclusion.
- The outcomes of the investigation would be valuable for researchers, designers, and developers of the domain.



# Thank you

This work has been funded with the help of Universidad de Malaga (Campus de Excelencia Internacional Andalucia Tech)