

Causal Modeling of the Glucose-Insulin System in Type-I Diabetic Patients

J. Fernandez, N. Aguilar, R. Fernandez de Canete, J.C. Ramos-Diaz

Abstract—In this paper a simulation model of the glucose-insulin system for a patient undergoing diabetes Type 1 is developed by using a causal modeling approach under System Dynamics. The OpenModelica simulation environment has been employed to build the so called causal model, while the glucose-insulin model parameters were adjusted to fit recorded mean data of a diabetic patient database. Model results under different conditions of a three-meal glucose and exogenous insulin ingestion patterns have been obtained. This simulation model can be useful to evaluate glucose-insulin performance in several circumstances, including insulin infusion algorithms in open-loop and decision support systems in closed-loop.

Keywords— causal modeling, diabetes, glucose-insulin system, diabetes, causal modeling, OpenModelica software.

I. INTRODUCTION

SYSTEM DYNAMICS provides a general purpose approach to the modeling of dynamic systems in many areas ranging from environmental sciences to engineering sciences [1], also in biomedical engineering particular [2]. Indeed, many educational programs have included System Dynamics together with computer simulation in courses syllabus due to its intuitive approach [3].

The use of modeling techniques through System Dynamics provides a more accurate description of the behavior of physiological systems. Often, these systems are so complex that it is not possible to obtain information about their performance, however, using models based on relationships of influence between variables and their subsequent computer simulation allows to predict the dynamic behavior [4], making possible the realization of experiences on the system under simulation, even in pathological conditions difficult to apply in clinical practice [5].

According to the WHO, diabetes is one of the 10 leading causes of death in the world. It is a disease present worldwide and both prevention and treatment are complicated. In addition to being a very common disorder in the population, it has doubled in recent decades, becoming one of the most common diseases in the world, and especially in developed countries due to the increase in obesity [6].

There are an increasing in searching for methods to diagnose and treatment of this disease, and the use of mathematical models that provide a deeper description of the deranged system, that is, of the glucose-insulin system, becomes useful.

J. Fernandez is with the System Engineering and Automation Dpt. University of Malaga, SPAIN. (e_mail: ffernandezr@uma.es).

N. Aguilar collaborates with the System Engineering and Automation Dpt. University of Malaga, SPAIN. (e_mail: natiaguilarperez@gmail.com).

In the case of diabetes mellitus, there are several studies that model this pathology using differential equations and software implementations [7] but there is little information regarding the use of causal diagrams. With this type of diagrams it is possible to present complex systems in a simple way, and with the subsequent transformation into flow diagrams, it can be obtained valid results and in a simpler way than using equations or developing code, difficult to understand by non-specialized medical personnel.

The object-oriented environment Modelica [8] is ideally suited as an architectural description language for System Dynamics approach, which allows the physical system to be simulated starting from causal diagrams, in particular through the open access version OpenModelica.

This paper deals with the development of a mathematical model of the glucose-insulin regulation system in patients with diabetes through the analysis of influence or causal diagrams, which allows explaining the behavior of the glucose-insulin system in different situations of ingestion of glucose and administration of exogenous insulin. The OpenModelica simulation environment has been used to implement the dynamic model and several experiences have been conducted to show its prediction ability.

II. MODEL OF DIABETIC PATIENT

Diabetic models are useful for estimating the blood glucose level when exogenous insulin rates are administered. Several models have been developed to characterize the diabetes dynamics, most of them by using the multi-compartmental approach [9] (Fig. 1).

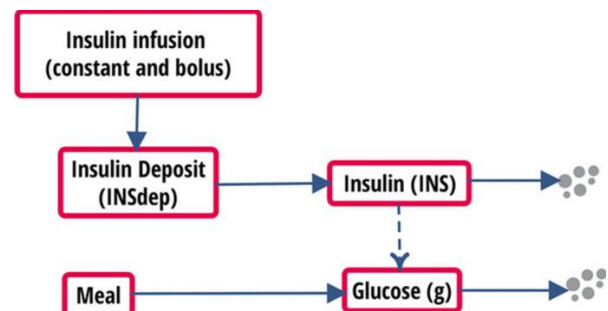

Fig. 1. Scheme of multi-compartmental model of glucose-insulin

R. Fernandez de Canete collaborates with the System Engineering and Automation Dpt. University of Malaga, SPAIN. (canete17@gmail.com)

J. C. Ramos-Diaz is with Pediatric Service, Antequera District Hospital, Malaga, SPAIN (e_mail: juancarlosramosdiaz@hotmail.com)

A type 1 diabetic patient model has been assumed following the nonlinear minimal model as described in [10] defined by a glucose subsystem and an insulin subsystem which determines the behavior of the blood glucose concentration in response to an exogenous insulin infusion while disturbances are also added in terms of dose of carbohydrates during meals.

The dynamic model is described by the following differential equations for the glucose subsystem as

$$\frac{dG(t)}{dt} = -(k_1 + k_2 i_3(t))G(t) + k_3 + RG(t) \quad (1)$$

while the insulin subsystem is modeled as a three compartment system as

$$\frac{di_3(t)}{dt} = -a_1 i_3(t) + a_2 i_1(t) \quad (2)$$

$$\frac{di_2(t)}{dt} = -a_5 i_2(t) + a_6 i_1(t) \quad (3)$$

$$\frac{di_1(t)}{dt} = -a_3 i_1(t) + a_4 i_3(t) + a_5 i_2(t) + a_7 RI(t) \quad (4)$$

being $G(t)$ plasma glucose concentration, $i_1(t)$ insulin mass in blood, $i_2(t)$ and $i_3(t)$ insulin mass in fast and slow equilibrium with insulin in the blood respectively, $RI(t)$ intravenous insulin delivery rate and $RG(t)$ rate of appearance of exogenous glucose following a meal, while k_1, k_2 are fractional transfer rates, k_3 is the rate of glucose appearance and $a_1 \dots a_6$ are fractional transfer rates.

The glucose blood level is described using a single compartment representing the blood plasma where a glucose balance including hepatic glucose balance, peripheral tissue glucose uptake, and glucose absorption from the gut has been made. The insulin blood level is determined by three connected compartments defining the time-varying distribution of insulin in blood.

III. CAUSAL MODELING

Qualitative model formulation enables obtaining a conceptual model where no explicit equations are contained but diagrams as the usual representation, either building causal diagrams or else Forrester diagrams [11].

Forrester diagrams are designed to represent systems in terms of basic concepts of system components and material flows between components so as to build a qualitative model easier to understand than mathematical models.

The elements involved in a Forrester diagram are represented by variables that can be of three types, level variables, flow variables, auxiliary variables and exogenous variables (Fig. 3).

Level variables define components and represent stock, accumulation, or state variables changing their value by accumulating or integrating rates. Flow variables define transfer between components and represent activity, movement or change of values of levels, and are dependent both on the levels in a system and on exogenous variables. Auxiliary variables are useful in formulating complex flow variables and are used for ease of communication and clarity. In addition to

this, there are also sources representing systems of levels and flows outside the boundary of the model and sinks where flows terminate outside the system.

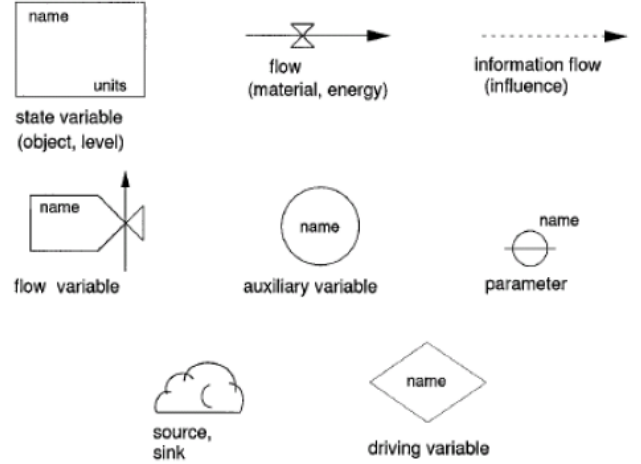

Fig. 2. Constitutive blocks of Forrester diagram

Relations between levels (L), sources (So) and sinks (Sk) are given by flow rates while information flow is needed to define flow (F) and auxiliary variables (A). In Fig. 3 levels are represented as “tanks” (rectangles), flows as “valves” while source and sinks are characterized by “clouds”. Auxiliary variables when needed as shaped as “circles”.

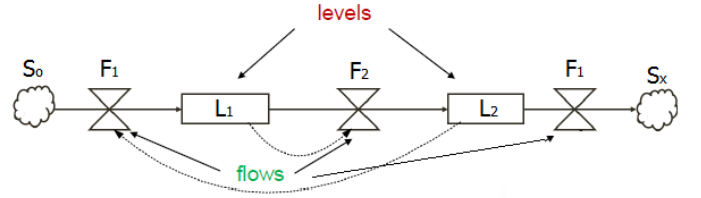

Fig. 3. Scheme of multi-compartmental model of glucose-insulin

According to classical hydrodynamics, level variations depend on the input and output flows that are controlled by valves, while valve operation depends on information about levels through auxiliary variables, so that for each level a corresponding equation of balance is derived as

$$\frac{dL_i(t)}{dt} = \sum F_{in}(t) - \sum F_{out}(t) \quad (5)$$

Thus, in the particular case of Fig. 2 system equations result in

$$\frac{dL_1(t)}{dt} = F_1(t) - F_2(t) \quad (6)$$

$$\frac{dL_2(t)}{dt} = F_2(t) - F_3(t) \quad (7)$$

Therefore, by following an inverse procedure, starting from the dynamic equations relative to the glucose-insulin system it can be easily derived the Forrester diagram by identifying which are level, flow and auxiliary variables respectively for

each equation, connecting them appropriately afterwards.

Starting from eq. (1) it can be reassigned as

$$\frac{dL_1(t)}{dt} = -f_{11}(t) - f_{12}(t) + f_{13}(t) + f_{14}(t) \quad (8)$$

constituted by one level $L_1(t) = G(t)$ and four flow variables as $f_{11}(t) = k_1 G(t)$, $f_{12}(t) = k_2 i_3(t) G(t)$, $f_{13}(t) = k_3$ and $f_{14}(t) = RG(t)$.

In the same way, eq. (2) would be represented as

$$\frac{dL_2(t)}{dt} = -f_{21}(t) + f_{22}(t) \quad (9)$$

defined by level $L_2(t) = i_3(t)$ and two flow variables as $f_{21}(t) = a_1 i_3(t)$ and $f_{22}(t) = a_2 i_1(t)$ and eq. (3) would convert to

$$\frac{dL_3(t)}{dt} = -f_{31}(t) + f_{32}(t) \quad (10)$$

with by another level $L_3(t) = i_2(t)$ and two flow variables again as $f_{31}(t) = a_5 i_2(t)$ and $f_{32}(t) = a_6 i_1(t)$.

Finally, last eq. (4) can be expressed as

$$\frac{dL_4(t)}{dt} = -f_{41}(t) + f_{42}(t) + f_{43}(t) + f_{44}(t) \quad (11)$$

constituted by level $L_4(t) = i_1(t)$ and four flow $f_{41}(t) = a_3 i_1(t)$, $f_{42}(t) = a_4 i_3(t)$, $f_{43}(t) = f_{31}(t)$ and $f_{44}(t) = a_7 RI(t)$. In this case, due to simple formulation of flow variables it is not necessary to use auxiliary variables. Both $RG(t)$ and $RI(t)$ are the external variables or inputs to the glucose-insulin system while and $i_1(t)$ are considered as the corresponding outputs.

Once the level, flow and auxiliary variables have been identified in eq. (9)-(11) it can be easily drawn a causal diagram useful to explain the underlying behavior of the glucose-insulin system in terms of influence relations (Fig. 4).

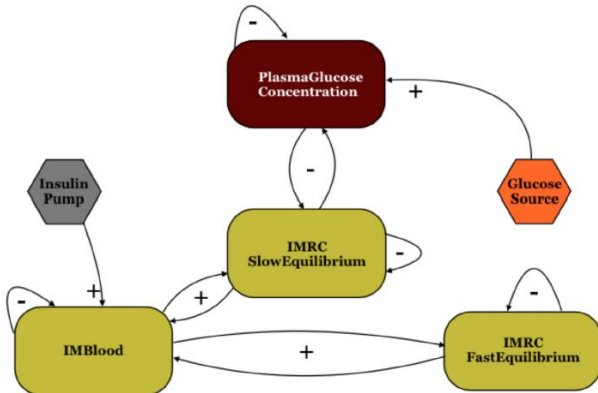

Fig. 4. Causal diagram of the glucose-insulin dynamics.

In the same way, the corresponding Forrester diagrams can be built so that it is facilitated the comprehension of the glucose-insulin dynamics in terms of the hydrodynamic analogy stated formerly in eq. (5).

OpenModelica includes the basic models implementing the System Dynamics methodology in a complete block-library, constituted by levels, rates, auxiliary and some other blocks so as to construct the Forrester diagram in very little time and with reduced effort [12].

In Fig. 5 it is shown the Forrester diagram corresponding to the glucose dynamics characterized by eq. (8).

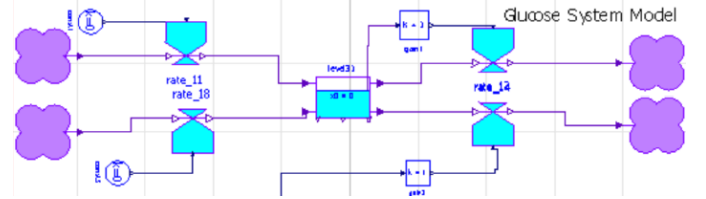

Fig. 5. Forrester causal diagram of the glucose dynamics.

As it can be seen one level and four flowrates define the glucose dynamics according to eq. (8), with corresponding flow variables dependence.

In Fig. 6 it is also shown the three stages Forrester diagram corresponding to the insulin dynamics characterized by eq. (9)-(11) where it can be distinguished three levels each corresponding to each different insulin state from insulin mass in fast and slow equilibrium with insulin in the blood and insulin mass in blood specifically.

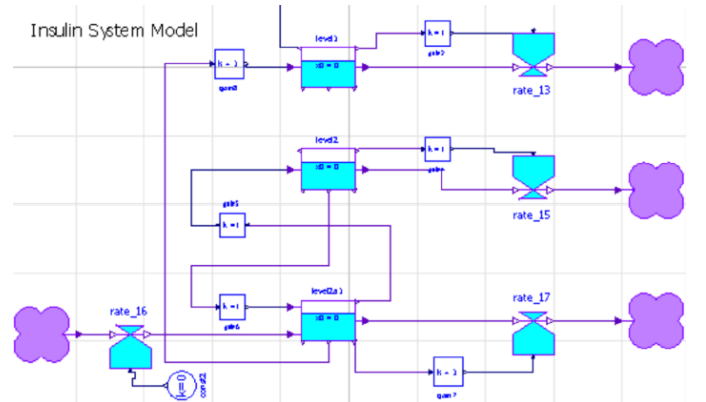

Fig. 6. Forrester causal diagram of the three-compartmental insulin dynamics.

The Forrester diagram of the whole glucose-insulin dynamic system is obtained by simply integrating the Forrester diagrams of glucose and insulin as it is depicted in Fig. 7.

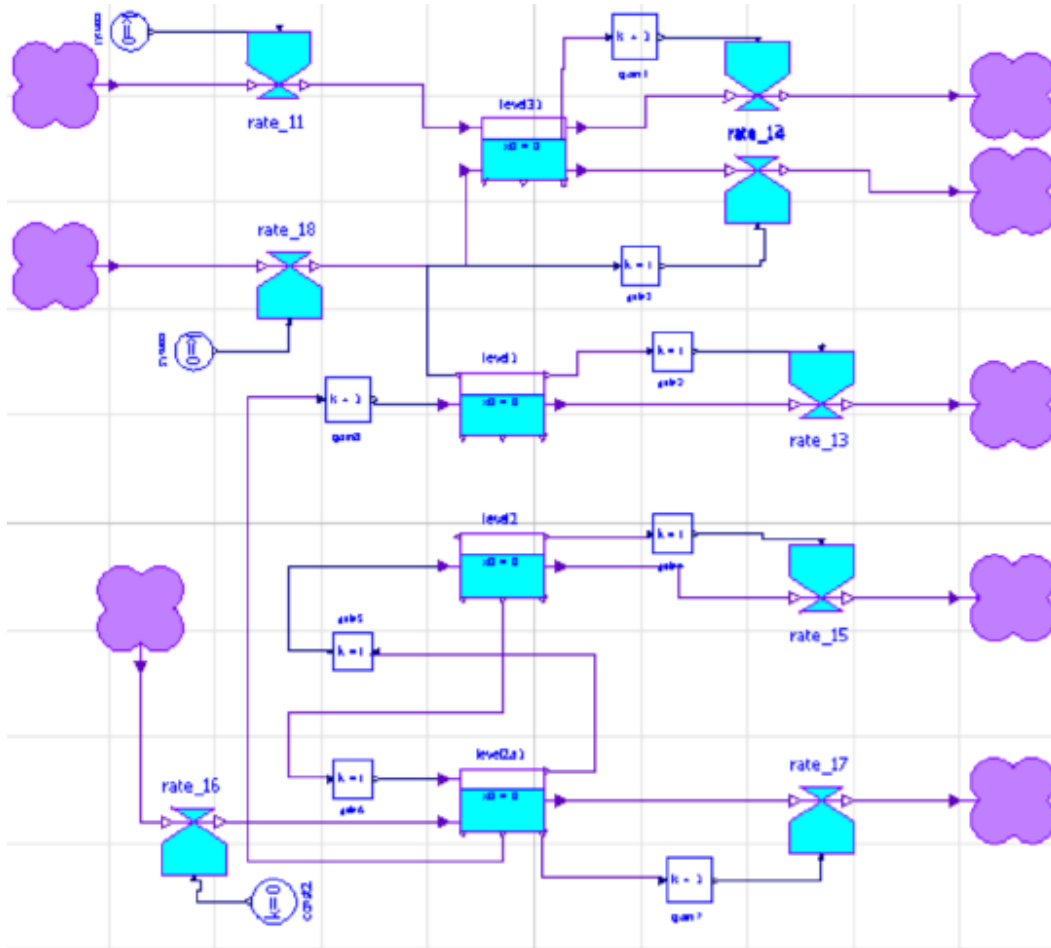

Fig. 7. Forrester causal diagram of the whole glucose-insulin dynamics.

IV. SIMULATION RESULTS

In this section, different experiences will be made on the glucose-insulin model of a patient with type 1 diabetes. For this purpose, values will be established for the parameters that are taken in the model and executed by simulation in OpenModelica, obtaining the results in terms of evolution of blood glucose and insulin levels.

In this work the simulation of the glucose-insulin system of a patient with type 1 diabetes is performed, following the following protocol: 45 g of glucose ingested at 8:00 h with the injection of 3 IU of insulin, 70 g of glucose at 12:00 h., with 4.5 IU of insulin and another dose equal to the latter of glucose and insulin at 20:00 h.

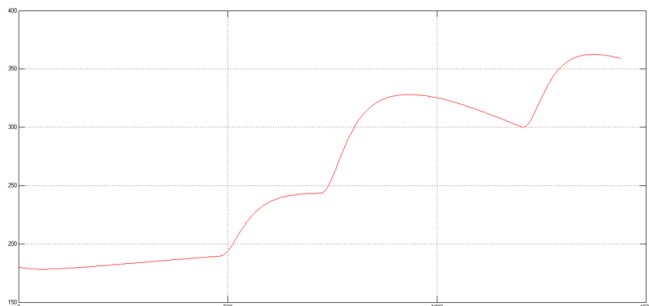

Fig. 8. Evolution of glucose concentration in plasma.

In Fig. 8 it is shown the plasma glucose curve where it is observed an increasing due to the glucose intake pattern, together with a posterior decreasing due to insulin injection, causing the glycemic balance to be reached, showing Fig. 9 the corresponding mass of insulin in plasma.

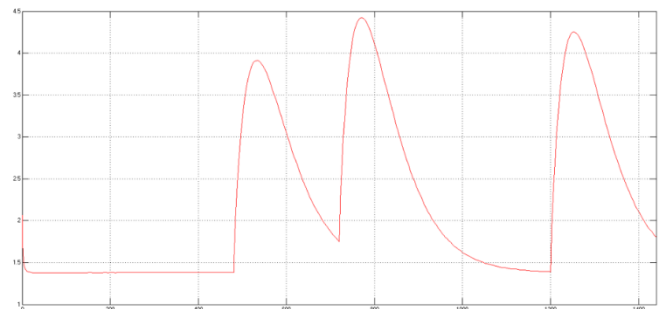

Fig. 9. Evolution of insulin mass in plasma.

In a new experience the patient triples the insulin dose by calculation error. It is observed in Fig. 10 that in this case hypoglycemia occurs, that is to say, a low blood glucose level where the patient may have tremors, seizures, blurred vision, fainting and even coma if the situation is extreme. In Fig. 11 it is also shown the insulin mass in plasma.

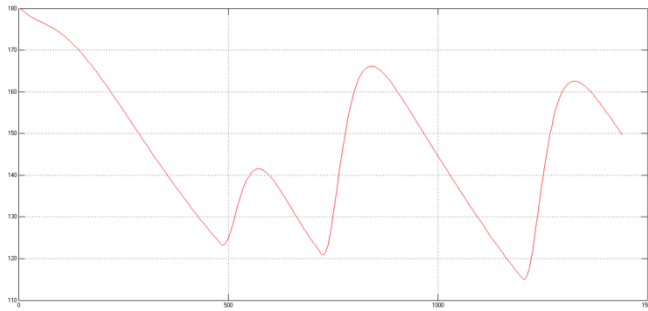

Fig. 10. Evolution of glucose concentration in plasma with triple insulin dose.

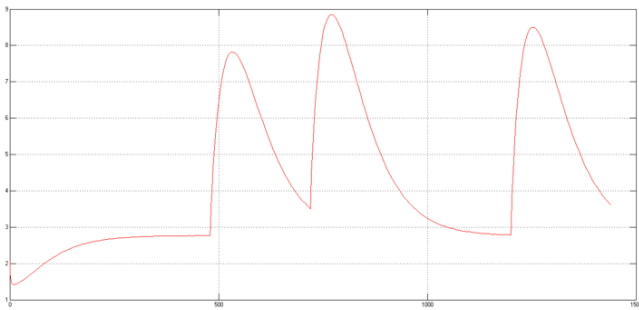

Fig.11. Evolution of insulin mass in plasma with triple insulin dose

V. CONCLUSIONS

A model of the glucose-insulin regulation system in patients with diabetes type-I has been built through the analysis of influence or causal diagrams and Forrester diagrams, which allows explaining the behavior of the glucose-insulin system in different situations of ingestion of glucose and administration of exogenous insulin in a simple and didactic way. The OpenModelica simulation environment has been used to implement the dynamic model and several experiences have been conducted to show its prediction ability.

As future work, it would be worth noting the incorporation of glucagon into the model, which is another of the hormones that secrete the pancreas through insulin, seeing the effect of the relationship and the interaction between this hormone and glucose.

REFERENCES

- [1] J. D. Sterman, "System dynamics modeling: Tools for learning in a complex world". *California management review*. 43 (4), 2001, 8–25.
- [2] D.M. Rubin, C.L. Richards, P.A. Keene, J.E. Paiker, A.R. Gray, R.F. Herron, M.J. Russell, B. Wigdorowitz, "System dynamics in medical education: a tool for life", *Adv Health Sci Educ Theory Pract.*, vol. 17(2), 2012, pp. 203-210.
- [3] G. Li, J. Gao, F. Chen "Construction of causality diagram model for diagnostics", *Reliability and Maintainability Symposium, 2008. RAMS 2008*, pp. 125-130.
- [4] Y. Okuda, E.O. Bryson, S. De Maria, L. Jacobson, J. Quinones, B. Shen, A.I. Levine, "The utility of simulation in medical education: what is the evidence?", *Mt Sinai J Med*, Vol. 76(4), 2009, pp. 330-343.
- [5] J.A. Gordon, J. Pawlowski, "Education on-demand: the development of a simulator-based medical education service", *Acad Med.*, vol. 77(7), 2002, pp. 751-752.
- [6] World Health Organization. *Global report on diabetes*, Geneva, 2016.

- [7] C. Dallaman, D.M. Raimondo, R.A. Rizza, C. Cobelli, c. "GIM, Simulation Software of Meal Glucose-Insulin Model", *J. Diab Sci and Technology*, vol. 1(3), 2007, pp. 323-330.
- [8] P. Fritzson. *Principles of Object-oriented Modeling and Simulation with Modelica 2.1*: Wiley-IEEE Press, 2003.
- [9] A. Makroglou, J. Li, Y. Kuang "Mathematical models and software tools for the glucose-insulin regulatory system and diabetes: An overview", *Applied Numerical Mathematics* vol. 56, pp. 559–573.
- [10] B.R. Hipszer. *A type 1 diabetic model*. M. A. Thesis, Submitted to the Faculty of Drexel University, 2001.
- [11] G. Coyle, "Qualitative and quantitative modelling in system dynamics: some research questions", *Sys Dyn Rev*, vol. 16(3), 2000, pp. 225-244.
- [12] F. Cellier, "World3 in Modelica: Creating System Dynamics Models in the Modelica Framework", in: *Proceedings of the 7th International Modelica Conference 2008*, pp. 393-400.